

Maintenance Manual

Series MG369xB Synthesized Signal Generators

The Anritsu logo is located in the bottom right corner of the page. It consists of the word "Anritsu" in a bold, sans-serif font, with a stylized diagonal slash through the letter 'A'.

WARRANTY

The Anritsu product(s) listed on the title page is (are) warranted against defects in materials and workmanship for three years from the date of shipment.

Anritsu's obligation covers repairing or replacing products which prove to be defective during the warranty period. Buyers shall prepay transportation charges for equipment returned to Anritsu for warranty repairs. Obligation is limited to the original purchaser. Anritsu is not liable for consequential damages.

LIMITATION OF WARRANTY

The foregoing warranty does not apply to defects resulting from improper or inadequate maintenance by the User, unauthorized modification or misuse, or operation outside of the specifications of the product. No other warranty is expressed or implied, and the remedies provided herein are the User's sole and exclusive remedies.

DISCLAIMER OF WARRANTY

DISCLAIMER OF WARRANTIES. TO THE MAXIMUM EXTENT PERMITTED BY APPLICABLE LAW, ANRITSU COMPANY AND ITS SUPPLIERS DISCLAIM ALL WARRANTIES, EITHER EXPRESS OR IMPLIED, INCLUDING, BUT NOT LIMITED TO, IMPLIED WARRANTIES OF MERCHANTABILITY AND FITNESS FOR A PARTICULAR PURPOSE, WITH REGARD TO THE SOFTWARE PRODUCT. THE USER ASSUMES THE ENTIRE RISK OF USING THE PROGRAM. ANY LIABILITY OF PROVIDER OR MANUFACTURER WILL BE LIMITED EXCLUSIVELY TO PRODUCT REPLACEMENT.

NO LIABILITY FOR CONSEQUENTIAL DAMAGES. TO THE MAXIMUM EXTENT PERMITTED BY APPLICABLE LAW, IN NO EVENT SHALL ANRITSU COMPANY OR ITS SUPPLIERS BE LIABLE FOR ANY SPECIAL, INCIDENTAL, INDIRECT, OR CONSEQUENTIAL DAMAGES WHATSOEVER (INCLUDING, WITHOUT LIMITATION, DAMAGES FOR LOSS OF BUSINESS PROFITS, BUSINESS INTERRUPTION, LOSS OF BUSINESS INFORMATION, OR ANY OTHER PECUNIARY LOSS) ARISING OUT OF THE USE OF OR INABILITY TO USE THE SOFTWARE PRODUCTS, EVEN IF ANRITSU COMPANY HAS BEEN ADVISED OF THE POSSIBILITY OF SUCH DAMAGES. BECAUSE SOME STATES AND JURISDICTIONS DO NOT ALLOW THE EXCLUSION OR LIMITATION OF LIABILITY FOR CONSEQUENTIAL OR INCIDENTAL DAMAGES, THE ABOVE LIMITATION MAY NOT APPLY TO YOU.

TRADEMARK ACKNOWLEDGMENTS

Windows is a registered trademark of Microsoft Corporation.
Acrobat Reader is a registered trademark of Adobe Corporation.
NI and NI-VISA are trademarks of the National Instruments Corporation.

NOTICE

Anritsu Company has prepared this manual for use by Anritsu Company personnel and customers as a guide for the proper installation, operation and maintenance of Anritsu Company equipment and computer programs. The drawings, specifications, and information contained herein are the property of Anritsu Company, and any unauthorized use or disclosure of these drawings, specifications, and information is prohibited; they shall not be reproduced, copied, or used in whole or in part as the basis for manufacture or sale of any equipment or software programs without the prior written consent of Anritsu Company.

UPDATES

Updates, if any, can be downloaded from the Documents area of the Anritsu web site at:
<http://www.anritsu.com>

END-USER LICENSE AGREEMENT FOR ANRITSU SOFTWARE

IMPORTANT-READ CAREFULLY: This End-User License Agreement (EULA) is a legal agreement between you (either an individual or a single entity) and Anritsu for the MG369xB software product identified above, which includes computer software and associated media and printed materials, and may include “online” or electronic documentation (“SOFTWARE PRODUCT” or “SOFTWARE”). By receiving or otherwise using the SOFTWARE PRODUCT, you agree to be bound by the terms of this EULA.

SOFTWARE PRODUCT LICENSE

The SOFTWARE PRODUCT is protected by copyright laws and international copyright treaties, as well as other intellectual property laws and treaties. The SOFTWARE PRODUCT is licensed, not sold.

1. **GRANT OF LICENSE.** This EULA grants you the following rights:

a. You may use ONE copy of the Software Product identified above only on the hardware product (MG369xB Signal Generator and its internal computer) to which it was originally installed. The SOFTWARE is in “use” on a computer when it is loaded into temporary memory (for example, RAM) or installed into permanent memory (for example, hard disk, CD-ROM, or other storage device) of that computer. However, installation on a network server for the sole purpose of internal distribution to one or more other computer(s) shall not constitute “use.”

b. Solely with respect to electronic documents included with the SOFTWARE, you may make an unlimited number of copies (either in hardcopy or electronic form), provided that such copies shall be used only for internal purposes and are not republished or distributed to any third party.

2. **OWNERSHIP.** Except as expressly licensed to you in this Agreement, Anritsu retains all right, title, and interest in and to the SOFTWARE PRODUCT; provided, however, that, subject to the license grant in Section 1.a and Anritsu's ownership of the underlying SOFTWARE PRODUCT, you shall own all right, title and interest in and to any Derivative Technology of the Product created by or for you.

3. **COPYRIGHT.** All title and copyrights in and to the SOFTWARE PRODUCT (including but not limited to any images, photographs, animations, video, audio, music, text, and “applets” incorporated into the SOFTWARE PRODUCT), the accompanying printed materials, and any copies of the SOFTWARE PRODUCT are owned by Anritsu or its suppliers. The SOFTWARE PRODUCT is protected by copyright laws and international treaty provisions. Therefore, you must treat the SOFTWARE PRODUCT like any other copyrighted material except that you may make one copy of the SOFTWARE PRODUCT solely for backup or archival purposes. You may not copy any printed materials accompanying the SOFTWARE PRODUCT.

4. **DESCRIPTION OF OTHER RIGHTS AND LIMITATIONS.**

a. **Limitations on Reverse Engineering, Decompilation, and Disassembly.** You may not reverse engineer, decompile, or disassemble the SOFTWARE, except and only to the extent that such activity is expressly permitted by applicable law notwithstanding this limitation.

b. **Rental.** You may not rent or lease the SOFTWARE PRODUCT.

c. **Software Transfer.** You may permanently transfer all of your rights under this EULA, provided that you retain no copies, you transfer all of the SOFTWARE PRODUCT (including the MG369xB Signal Generator, all component parts, the media and printed materials, any upgrades, this EULA, and, if applicable, the Certificate of Authenticity), and the recipient agrees to the terms of this EULA.

d. **Termination.** Without prejudice to any other rights, Anritsu may terminate this EULA if you fail to comply with the terms and conditions of this EULA. In such event, you must destroy all copies of the SOFTWARE PRODUCT.

5. **U.S. GOVERNMENT RESTRICTED RIGHTS. THE SOFTWARE PRODUCT AND DOCUMENTATION ARE PROVIDED WITH RESTRICTED RIGHTS. USE, DUPLICATION, OR DISCLOSURE BY THE GOVERNMENT IS SUBJECT TO RESTRICTIONS AS SET FORTH IN SUBPARAGRAPH (C)(1)(II) OF THE RIGHTS IN TECHNICAL DATA AND COMPUTER SOFTWARE CLAUSE AT DFARS 252.227-7013 OR SUBPARAGRAPHS (C)(1) AND (2) OF THE COMMERCIAL COMPUTER SOFTWARE-RESTRICTED RIGHTS AT 48 CFR 52.227-19, AS APPLICABLE. MANUFACTURER IS ANRITSU COMPANY, 490 JARVIS DRIVE, MORGAN HILL, CALIFORNIA 95037-2809.**

The MG369xB software is copyright © 2015, Anritsu Company. All rights are reserved by all parties.

DECLARATION OF CONFORMITY

Manufacturer's Name: ANRITSU COMPANY

Manufacturer's Address: Microwave Measurements Division
490 Jarvis Drive
Morgan Hill, CA 95037-2809
USA

declares that the product specified below:

Product Name: Signal Generator

Model Number: MG3691B, MG3692B, MG3693B
MG3693B, MG3695B, MG3696B

conforms to the requirement of:

EMC Directive 89/336/EEC as amended by Council Directive 92/31/EEC & 93/68/EEC
Low Voltage Directive 73/23/EEC as amended by Council directive 93/68/EEC

Electromagnetic Interference:

Emissions: CISPR 11:1990/EN55011: 1991 Group 1 Class A
EN 61000-3-2:1995 Class A
EN 61000-3-3:1995 Class A

Immunity: EN 61000-4-2:1995/EN61326-1: 1997 - 4kV CD, 8kV AD
EN 61000-4-3:1997/ EN61326-1: 1997- 3V/m
EN 61000-4-4:1995/ EN61326-1997: 1997 - 0.5kV SL, 1kV PL
EN 61000-4-5:1995/ EN61326-1997: 1997 - 1kV L-L, 2kV L-E
EN 61000-4-6:1994/EN61326: 1998 - 3V
EN 61000-4-11:1994/EN61326: 1998 - 100% @ 20msec

Electrical Safety Requirement:

Product Safety: IEC 1010-1:1990 + A1/EN61010-1: 1993

Eric McLean, Corporate Quality Director

Morgan Hill, CA

12/14/04
Date

European Contact: For Anritsu product EMC & LVD information, contact Anritsu LTD, Rutherford Close,
Stevenage Herts, SG1 2EF UK, (FAX 44-1438-740202)

CE Conformity Marking

Anritsu affixes the CE Conformity marking onto its conforming products in accordance with Council Directives of The Council Of The European Communities in order to indicate that these products conform to the EMC and LVD directive of the European Union (EU).



C-tick Conformity Marking

Anritsu affixes the C-tick marking onto its conforming products in accordance with the electromagnetic compliance regulations of Australia and New Zealand in order to indicate that these products conform to the EMC regulations of Australia and New Zealand.



Notes On Export Management

This product and its manuals may require an Export License or approval by the government of the product country of origin for re-export from your country.

Before you export this product or any of its manuals, please contact Anritsu Company to confirm whether or not these items are export-controlled.

When disposing of export-controlled items, the products and manuals need to be broken or shredded to such a degree that they cannot be unlawfully used for military purposes.

Mercury Notification

This product uses an LCD backlight lamp that contains mercury. Disposal may be regulated due to environmental considerations. Please contact your local authorities or, within the United States, the Electronics Industries Alliance (www.eiae.org) for disposal or recycling information.

Chinese RoHS Compliance Statement

产品中有毒有害物质或元素的名称及含量

For Chinese Customers Only YLNB

部件名称	有毒有害物质或元素					
	铅 (Pb)	汞 (Hg)	镉 (Cd)	六价铬 [Cr (VI)]	多溴联苯 (PBB)	多溴二苯醚 (PBDE)
印刷线路板 (PCA)	×	○	×	×	○	○
机壳、支架 (Chassis)	×	○	×	×	○	○
LCD	×	×	×	×	○	○
其他(电缆、风扇、 连接器等) (Appended goods)	×	○	×	×	○	○

○：表示该有毒有害物质在该部件所有均质材料中的含量均在 SJ/T11363-2006 标准规定的限量要求以下。
 ×：表示该有毒有害物质至少在该部件的某一均质材料中的含量超出 SJ/T11363-2006 标准规定的限量要求。

环保使用期限



这个标记是根据 2006/2/28 公布的「电子信息产品污染控制管理办法」以及 SJ/T 11364-2006 「电子信息产品污染控制标识要求」的规定，适用于在中国销售的电子信息产品的环保使用期限。仅限于在遵守该产品的安全规范及使用注意事项的基础上，从生产日起算的该年限内，不会因产品所含有害物质的泄漏或突发性变异，而对环境污染，人身及财产产生深刻地影响。

注) 生产日期标于产品序号的前四码(如 S/N 0728XXXX 为 07 年第 28 周生产)。

European Parliament and Council Directive 2002/96/EC

Equipment marked with the Crossed-out Wheelie Bin symbol complies with the European Parliament and Council Directive 2002/96/EC (the "WEEE Directive") in the European Union.



For Products placed on the EU market after August 13, 2005, please contact your local Anritsu representative at the end of the product's useful life to arrange disposal in accordance with your initial contract and the local law.

Safety Symbols

To prevent the risk of personal injury or loss related to equipment malfunction, Anritsu Company uses the following symbols to indicate safety-related information. For your own safety, please read the information carefully *before* operating the equipment.

Symbols Used in Manuals

Danger



This indicates a very dangerous procedure that could result in serious injury or death, and possible loss related to equipment malfunction, if not performed properly.

Warning



This indicates a hazardous procedure that could result in light-to-severe injury or loss related to equipment malfunction, if proper precautions are not taken.

Caution



This indicates a hazardous procedure that could result in loss related to equipment malfunction if proper precautions are not taken.

Safety Symbols Used on Equipment and in Manuals

The following safety symbols are used inside or on the equipment near operation locations to provide information about safety items and operation precautions. Ensure that you clearly understand the meanings of the symbols and take the necessary precautions *before* operating the equipment. Some or all of the following five symbols may or may not be used on all Anritsu equipment. In addition, there may be other labels attached to products that are not shown in the diagrams in this manual.



This indicates a prohibited operation. The prohibited operation is indicated symbolically in or near the barred circle.



This indicates a compulsory safety precaution. The required operation is indicated symbolically in or near the circle.



This indicates a warning or caution. The contents are indicated symbolically in or near the triangle.



This indicates a note. The contents are described in the box.



These indicate that the marked part should be recycled.



For Safety

Warning



Always refer to the operation manual when working near locations at which the alert mark, shown on the left, is attached. If the operation, etc., is performed without heeding the advice in the operation manual, there is a risk of personal injury. In addition, the equipment performance may be reduced.

Moreover, this alert mark is sometimes used with other marks and descriptions indicating other dangers.

Warning

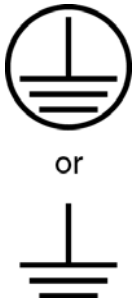

When supplying power to this equipment, connect the accessory 3-pin power cord to a 3-pin grounded power outlet. If a grounded 3-pin outlet is not available, use a conversion adapter and ground the green wire, or connect the frame ground on the rear panel of the equipment to ground. If power is supplied without grounding the equipment, there is a risk of receiving a severe or fatal electric shock.

Warning



This equipment can not be repaired by the operator. Do not attempt to remove the equipment covers or to disassemble internal components. Only qualified service technicians with a knowledge of electrical fire and shock hazards should service this equipment. There are high-voltage parts in this equipment presenting a risk of severe injury or fatal electric shock to untrained personnel. In addition, there is a risk of damage to precision components.

Warning



Use two or more people to lift and move this equipment, or use an equipment cart. There is a risk of back injury if this equipment is lifted by one person.

Caution



Electrostatic Discharge (ESD) can damage the highly sensitive circuits in the instrument. ESD is most likely to occur as test devices are being connected to, or disconnected from, the instrument's front and rear panel ports and connectors. You can protect the instrument and test devices by wearing a static-discharge wristband. Alternatively, you can ground yourself to discharge any static charge by touching the outer chassis of the grounded instrument before touching the instrument's front and rear panel ports and connectors. Avoid touching the test port center conductors unless you are properly grounded and have eliminated the possibility of static discharge.

Repair of damage that is found to be caused by electrostatic discharge is not covered under warranty.

Table of Contents

Chapter 1—General Information

1-1	Scope of Manual	1-1
1-2	Introduction	1-1
1-3	Description	1-1
1-4	Identification Number	1-1
1-5	Online Manual	1-1
1-6	Related Manuals	1-2
	Operation Manual	1-2
	GPIB Programming Manual	1-2
	SCPI Programming Manual	1-2
1-7	Options	1-2
1-8	Contacting Anritsu	1-2
1-9	Level of Maintenance	1-3
	Troubleshooting	1-3
	Repair	1-3
	Calibration	1-3
	Preventive Maintenance	1-3
1-10	ESD Requirements	1-3
1-11	Preventive Maintenance	1-4
1-12	Startup Configurations	1-5
1-13	Test Equipment List	1-6

Chapter 2—Functional Description

2-1	Introduction	2-1
2-2	Major Subsystems	2-1
	Digital Control	2-1
	Front Panel Assembly	2-1
	Frequency Synthesis	2-2
	A9 YIG Assembly	2-2
	ALC/AM/Pulse Modulator	2-2
	RF Deck	2-2
	Power Supply	2-2
	Inputs/Outputs	2-3
	Motherboard/Interconnections	2-3

Table of Contents (Continued)

2-3	Frequency Synthesis	2-6
	Phase Lock Loops	2-6
	Overall Operation	2-6
	RF Outputs 0.01 MHz to 65 or 67 GHz	2-10
	0.1 Hz to 10 MHz (Option 22)	2-10
	0.01 to 2.2 GHz (Option 4)	2-10
	0.01 to 2 GHz (Option 5)	2-10
	20 to 30 GHz (Model MG3693B)	2-10
	20 to 40 GHz (Model MG3694B)	2-10
	40 to 50 GHz (Model MG3695B)	2-10
	40 to 65 or 67 GHz (Model MG3696B)	2-10
	Frequency Modulation	2-11
	Phase Modulation	2-11
	Analog Sweep Mode	2-11
	Step Sweep Mode	2-12
2-4	ALC/AM/Pulse Modulation	2-12
	ALC Loop Operation	2-12
	External Leveling	2-12
	ALC Slope	2-13
	Power Sweep	2-13
	Amplitude Modulation	2-13
	Pulse Modulation Operation	2-13
	Pulse Generator Operation	2-13
2-5	RF Deck Assemblies	2-14
	RF Deck Configurations	2-14
	YIG-tuned Oscillator	2-14
	RF Signal Filtering	2-14
	0.01 to 2 GHz Down Converter (Option 5)	2-15
	0.01 to 2.2 GHz Digital Down Converter (Option 4)	2-15
	Switched Doubler Module	2-15
	Source Quadrupler Module	2-16
	Model MG3695B SQM Operation	2-16
	Model MG3696B SQM Operation	2-16
	Step Attenuators	2-16

Chapter 3—Performance Verification

3-1	Introduction	3-1
3-2	Test Records	3-1
3-3	Connector and Key Notation	3-1
3-4	Test Equipment List	3-2
3-5	Measurement Uncertainty	3-5
3-6	Internal Time Base Aging Rate Test (Optional)	3-5
	Internal Time Base Aging Rate Test with Absolute Time Model 300	3-6
	Internal Time Base Aging Rate Test with Symmetricom (Datum) Model 9390-9600	3-7

Table of Contents (Continued)

3-7	Spurious Signals Test	3-8
	Harmonic Test Initial Setup Procedure	3-8
	Harmonic Test Procedure	3-8
	Non-Harmonic Initial Setup Procedure	3-9
	Non-Harmonic Test Procedure	3-10
3-8	Single Sideband Phase Noise Test	3-12
	Agilent E5052B Signal Source Analyzer and E5053A Down Converter	3-12
	Test Setup	3-12
	Test Procedure	3-14
	AeroFlex PN9000 Phase Noise System	3-17
	Test Setup	3-18
	Test Procedure	3-18
3-9	Power Level Accuracy and Flatness Tests	3-22
	Test Setup	3-22
	Power Level Log Conformity	3-23
	Power Level Accuracy (≥ -50 dBm)	3-24
	Power Level Accuracy (< -50 dBm)	3-25
	Test Setup	3-25
	Test Procedure	3-26
	Power Level Flatness	3-28
	Test Setup	3-28
	Test Procedure	3-29
	Maximum Leveled Power	3-30
	Test Setup	3-30
	Test Procedure	3-31
3-10	Frequency Modulation and Phase Modulation Tests	3-32
	Test Setup	3-32
	Locked FM Accuracy	3-32
	Φ M Accuracy	3-36
	FM/ Φ M Flatness and Bandwidth	3-40
	Test Setup	3-40
	Modulation Index Calculations	3-44
	Unlocked Narrow FM Accuracy	3-46
	Test Setup	3-46
	Test Procedure	3-46
3-11	Amplitude Modulation Tests	3-48
	Test Setup	3-48
	External AM Accuracy	3-49
	Internal AM Accuracy	3-50
	AM Roll Off	3-51
	AM Flatness	3-53

Table of Contents (Continued)

3-12	Pulse Modulation Tests	3-55
	Test Setup	3-55
	Pulse Rise Time, Fall Time and Overshoot	3-56
	Pulse Power Accuracy	3-58
	Pulse On/Off Ratio	3-59
	Test Setup	3-60
	Test Procedure	3-60

Chapter 4—Adjustment

4-1	Introduction	4-1
4-2	Test Equipment List	4-1
4-3	Test Records	4-4
4-4	Subassembly Replacement	4-5
4-5	Connector and Key Notation	4-6
4-6	Initial Setup	4-6
	Interconnection	4-6
	PC Setup	4-7
4-7	Preliminary Calibration	4-9
	Equipment Setup	4-9
	Calibration Steps	4-9
	Alternate 10 MHz Reference Oscillator Calibration	4-11
4-8	Frequency Synthesis Tests	4-12
	Test Setup	4-12
	Coarse Loop/YIG Loop	4-12
	Fine Loop	4-13
4-9	Switched Filter Shaper	4-14
	Equipment Setup	4-14
	Log Amplifier Zero Calibration	4-14
	Limiter DAC Adjustment	4-15
	Shaper DAC Adjustment	4-16
4-10	RF Level Calibration	4-16
	Equipment Setup	4-20
4-11	ALC Bandwidth Calibration	4-21
	Equipment Setup	4-21
	Bandwidth Calibration	4-21
4-12	ALC Slope Calibration (Option 6 only)	4-22
	Equipment Setup	4-22
	ALC Slope DAC Adjustment (only for units with Option 6 Analog Sweep)	4-22
4-13	AM Calibration	4-25
	Equipment Setup	4-25
	AM Calibration Procedure	4-26
4-14	Frequency and Phase Modulation Calibration	4-28
	Equipment Setup	4-28
	FM Calibration Procedure	4-29

Table of Contents (Continued)

Chapter 5—Troubleshooting

5-1	Introduction	5-1
5-2	Test Equipment List	5-1
5-3	Error Messages	5-1
	Self-Test Error Messages	5-1
	Normal Operation Error and Warning/Status Messages	5-3
5-4	No Error Message.	5-5
5-5	Troubleshooting Tables	5-6

Chapter 6—Removal and Replacement Procedures

6-1	Introduction.	6-1
6-2	Replaceable Parts	6-1
6-3	Calibration and verifications after replacing an assembly.	6-4
6-4	Chassis Covers.	6-7
	Tool Required	6-7
	Preliminary.	6-7
	Procedure	6-7
6-5	Front Panel Assembly.	6-9
	Preliminary.	6-9
	Procedure	6-9
6-6	A2 Microprocessor PCB Board.	6-10
	Preliminary.	6-10
	Procedure	6-10
6-7	A3 Reference/Fine Loop PCB	6-11
	Preliminary.	6-11
	Procedure	6-11
6-8	A4 Coarse Loop PCB	6-12
	Preliminary.	6-12
	Procedure	6-12
6-9	A5 to A13 PCB Removal	6-14
	Preliminary.	6-14
	Card Cage Cover.	6-14
	A5 Auxiliary PCB	6-15
	A6 ALC PCB	6-15
	A7 YIG Lock PCB	6-16
	A9 YIG Assembly	6-16
	A13 Pulse Generator PCB.	6-16

Table of Contents (Continued)

6-10	Power Supply Assembly	6-17
	Preliminary	6-17
	Power Supply Top Assembly	6-17
	12 Volt Standby Power Supply PCB	6-18
	A20 Power Supply Regulator	6-19

Appendix A—Test Records

A-1	Introduction	A-1
A-2	Uncertainty Specifications	A-1
A-3	Test Records	A-1
	Section 3-6 Internal Time Base Aging Rate Test (Optional)	A-2
	Section 3-7 Harmonics and Harmonically Related Signal Test Records	A-3
	Section 3-7 Harmonics and Harmonically Related Signal Test Records	A-5
	Section 3-7 Non-Harmonics Signal Test (All MG369xB Models)	A-7
	Section 3-7 Non-Harmonics Signal Test (All MG369xB Models)	A-10
	Section 3-8 Single Sideband Phase Noise Test with Agilent E5052B Signal Source Analyzer and E5053A Down Converter	A-13
	Section 3-8 Single Sideband Phase Noise Test: Power Line and Fan Rotation Emissions with Agilent E5052B Signal Source Analyzer and E5053A Down Converter	A-22
	Section 3-8 Single Sideband Phase Noise Test with AeroFlex PN9000 Phase Noise System	A-25
	Section 3-8 Single Sideband Phase Noise Test: Power Line and Fan Rotation Emissions with AeroFlex PN9000 Phase Noise System	A-34
	Section 3-9 Power Level Log Conformity Test	A-37
	Section 3-9 Power Level Accuracy Test	A-39
	Section 3-9 Power Level Flatness Test	A-53
	Section 3-9 Maximum Leveled Power Test	A-57
	Section 3-10 Frequency Modulation Test	A-64
	Section 3-11 Amplitude Modulation Test	A-69
	Section 3-12 Pulse Modulation Test	A-73
	Section 4-7 Preliminary Calibration	A-76
	Section 4-8 Frequency Synthesis Test (1 of 3)	A-77
	Section 4-9 Switched Filter Shaper Calibration	A-80
	Section 4-10 RF Level Calibration	A-80
	Section 4-11 ALC Bandwidth Calibration	A-80
	Section 4-12 ALC Slope Calibration	A-80
	Section 4-13 AM Calibration	A-81
	Section 4-14 FM Calibration	A-81

Appendix B—Technical Data Sheet

B-1	MG369xB Technical Data Sheet	B-1
-----	--	-----

Index

Chapter 1 — General Information

1-1 Scope of Manual

This manual provides service information for the model MG369xB Signal Generators. The service information includes replaceable parts information, troubleshooting, performance verification tests, calibration procedures, functional circuit descriptions and block diagrams, and assembly/subassembly removal and replacement. Throughout this manual, the terms *MG369xB* or *synthesizer* are used to refer to the instrument. Manual organization is shown in the table of contents.

1-2 Introduction

This chapter provides a general description of the MG369xB identification numbers, related manuals, and options. Information is included concerning level of maintenance, replaceable subassemblies and RF components, exchange assembly program, and preventive maintenance. Static-sensitive component handling precautions and lists of exchangeable subassemblies and test equipment are also provided.

1-3 Description

The series MG369xB is a microprocessor-based, synthesized signal source with high resolution phase-lock capability. It generates both discrete CW frequencies and broad (full range) and narrow band step sweeps across the frequency range of 2 GHz to 67 GHz.

Note

All MG3696xB models with serial number 065215 and above are specified to 67 GHz and operational to 70 GHz. Earlier MG3696xB models were specified to 65 GHz and operational to 67 GHz.

Options are available to extend the low end of the frequency range to 0.1 Hz. All functions of the CW generator are fully controllable locally from the front panel or remotely (except for power on/standby) via the IEEE-488 General Purpose Interface Bus (GPIB). The technical data sheet in Appendix B of the printed version of this manual contains a list of all models and specifications. This data sheet (PN: 11410-00344) is also available online. Updates to this manual and the technical data sheet, if any, may be downloaded from the Anritsu Internet site at: <http://www.anritsu.com>.

1-4 Identification Number

All Anritsu instruments are assigned a unique six-digit ID number, such as “050101.” The ID number is imprinted on a decal that is affixed to the rear panel of the instrument. Special-order instrument configurations also have an additional special number tag attached to the rear panel of the instrument, such as SM1234.

When ordering parts or corresponding with Anritsu customer service, please use the correct serial number with reference to the specific instrument’s model number (i.e., model MG3692B Signal Generator, Serial No. 050101, and the special’s number, if appropriate).

1-5 Online Manual

This manual is available on CD ROM as an Adobe Acrobat Portable Document Format (*.pdf) file. The file can be viewed using Acrobat Reader, a free program that is also included on the CD ROM. The file is “linked” such that the viewer can choose a topic to view from the displayed “bookmark” list and “jump” to the manual page on which the topic resides. The text can also be searched.

1-6 Related Manuals

This is one of a four manual set that consists of an operation manual, a GPIB programming manual, a SCPI programming manual, and this maintenance manual.

Operation Manual

The operation manual provides instructions for operating the MG369xB using the front panel controls. It also includes general information, performance specifications, installation instructions, and operation verification procedures. The Anritsu part number for the model MG369xB Operation Manual is 10370-10365.

GPIB Programming Manual

The GPIB programming manual provides information for remotely operating the MG369xB using product specific commands sent from an external controller via the IEEE 488 General Purpose Interface Bus (GPIB). It contains a complete listing and description of all MG369xB GPIB product specific commands and several programming examples. The Anritsu part number for the model MG369xB GPIB Programming Manual is 10370-10366.

SCPI Programming Manual

The SCPI programming manual provides information for remotely operating the MG369xB using Standard Commands for Programmable Instruments (SCPI) commands. SCPI commands are a set of standard programming commands for use by all SCPI compatible instruments. SCPI is intended to give the ATE user a consistent environment for program development. It does so by defining controller messages, instrument responses, and message formats for all SCPI compatible instruments. The IEEE-488 (GPIB) interface for the MG369xB was designed to conform to the requirements of SCPI 1993.0. The set of SCPI commands implemented by the MG369xB GPIB interface provides a comprehensive set of programming functions covering all the major functions of the MG369xB signal generator. The Anritsu part number for the model MG369xB SCPI Programming Manual is 10370-10368.

1-7 Options

The options available for the Anritsu MG369xB series signal generators are described in the technical data sheet (PN: 11410-00344). The data sheet is located in Appendix B of the printed manual and online at the Anritsu web site (<http://www.anritsu.com>).

1-8 Contacting Anritsu

To contact Anritsu, please visit:

<http://www.anritsu.com/contact.asp>

From here, you can select the latest sales, select service and support contact information in your country or region, provide online feedback, complete a "Talk to Anritsu" form to have your questions answered, or obtain other services offered by Anritsu.

Updated product information can be found on the Anritsu web site:

<http://www.anritsu.com/>

Search for the product model number. The latest documentation is on the product page under the Library tab.

Example URL for MS2035B:

<http://www.anritsu.com/en-us/products-solutions/products/MS2035B.aspx>

1-9 Level of Maintenance

Maintenance of the MG369xB consists of:

- Troubleshooting the instrument to a replaceable subassembly or RF component
- Repair by replacing the failed subassembly or RF component.
- Calibration
- Preventive maintenance

Troubleshooting

The MG369xB firmware includes internal diagnostics that self-test most of the internal assemblies. When the MG369xB fails self-test, one or more error messages appear on screen to aid in isolating the failure to a replaceable subassembly or RF component. [Chapter 5, “Troubleshooting”](#) lists and describes the self-test error messages and provides procedures for isolating MG369xB failures to a replaceable subassembly or RF component.

Repair

Most instrument failures are field repairable by replacing the failed subassembly or RF component. Detailed instructions for removing and replacing failed subassemblies and components are provided in [Chapter 6, “Removal and Replacement Procedures”](#).

Calibration

The MG369xB may require calibration after repair. Refer to [Chapter 4, “Adjustment”](#) for a listing of requirements and procedures.

Preventive Maintenance

Preventive maintenance on the MG369xB consists of cleaning the fan honeycomb filter, described in [Section 1-11](#).

1-10 ESD Requirements

The MG369xB contains components that can be easily damaged by electrostatic discharge (ESD). An ESD safe work area and proper ESD handling procedures that conform to ANSI/ESD S20.20-1999 or ANSI/ESD S20.20-2007 is mandatory to avoid ESD damage when handling subassemblies or components found in the MG369xB instrument.

1-11 Preventive Maintenance

The MG369xB must always receive adequate ventilation. A blocked fan filter can cause the instrument to overheat and shut down. Check and clean the rear panel fan honeycomb filter periodically, especially in dusty environments. Clean the filter as follows.

1. Turn off the synthesizer and disconnect the power cord from the instrument.
2. Use a #3 screwdriver to remove the four screws that fasten the filter guard to the rear panel (see [Figure 1-1](#)). Retain the screws for reassembly.
3. Vacuum the honeycomb filter to clean it.
4. Reinstall the filter guard.
5. Fasten the filter guard to the rear panel using the four screws that were removed in step 1.

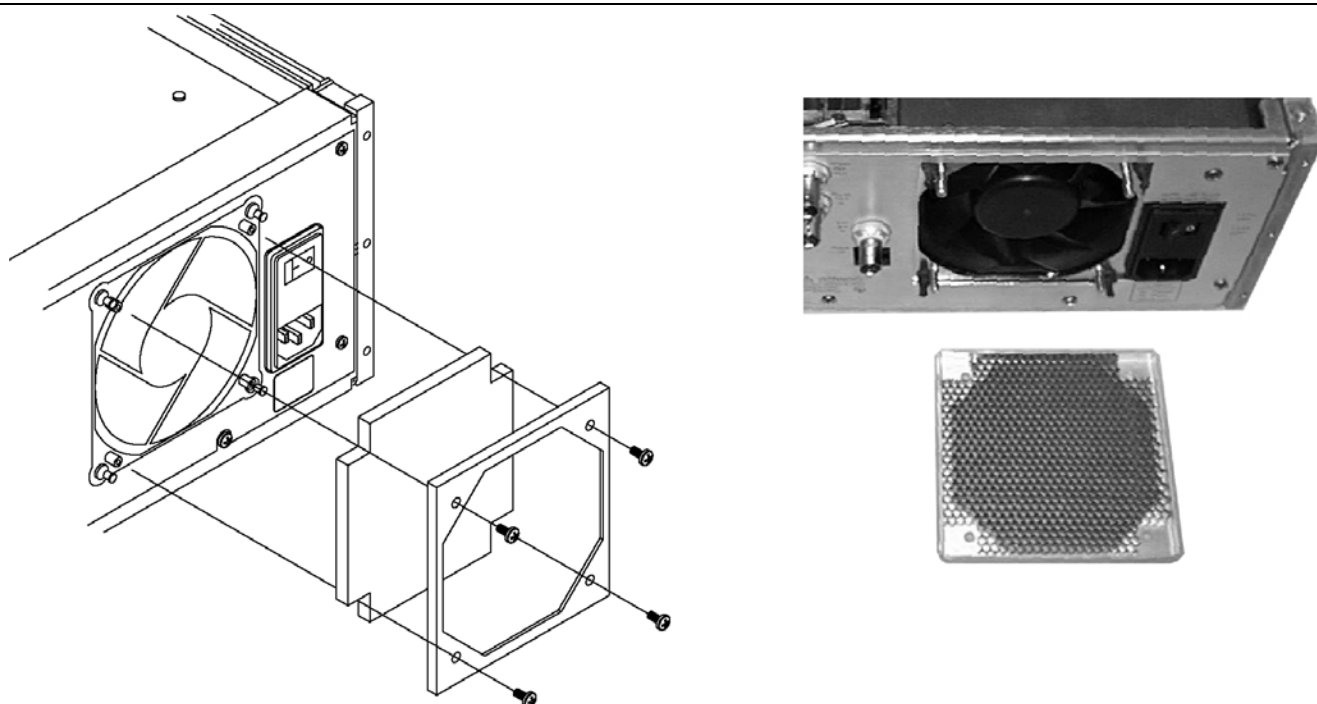

Figure 1-1. Removal/Replacement of the Fan Filter Guard

1-12 Startup Configurations

The MG369xB comes from the factory with a jumper across pins 2 and 3 of the A2 microprocessor PCB connector JP1 (Figure 1-2). In this configuration, connecting the instrument to line power automatically places it in operate mode (front panel OPERATE LED on).

The startup configuration can be changed so that the signal generator comes up in standby mode (front panel STANDBY LED on) when it is connected to line power. Change the startup configuration as follows:

1. Disconnect the instrument from line power.
2. Remove the top cover from the MG369xB and A2 PCB. Refer to [Section 6-4](#) and [Section 6-6](#) for instructions.
3. Locate the connector JP1 and remove the jumper from across pins 2 and 3. Refer to [Figure 1-2](#) below.
4. Install the jumper across pins 1 and 2 of the connector JP1.
5. Install the top covers and connect the signal generator to line power. The instrument should come up in standby mode.

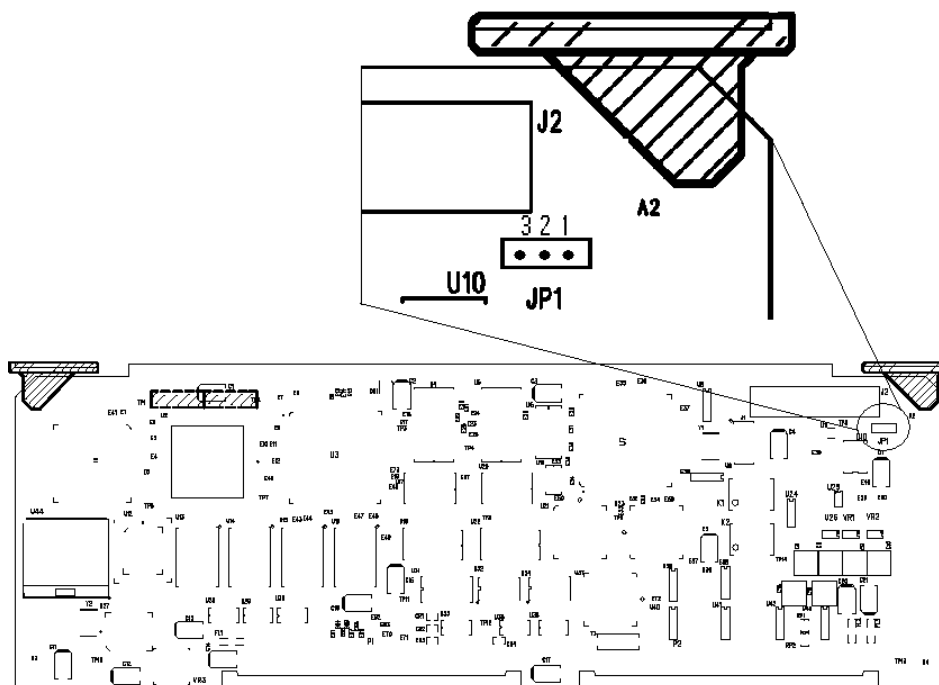

Figure 1-2. Startup Configuration of A2 Connector JP1

1-13 Test Equipment List

Table 1-1 provides a list of the test equipment for the performance verification tests and adjustments. The test equipment setup is critical to making accurate measurements. In some cases, you may substitute test equipment having the same critical specifications as the test equipment indicated in the test equipment list (refer to Section 3-5).

Table 1-1. Test Equipment List (Sheet 1 of 4)

Instrument	Critical Specification	Manufacturer/Model	Usage ⁽¹⁾
Computer running Windows XP	Can not exceed the following configuration: Pentium 4 2.8 GHz 1 GB of memory 2 Serial ports CDROM Mouse Keyboard Monitor Network The computer must be dedicated during calibration and verification activities.	Dell or other common source	C, P
National Instrument PCI GPIB card	PCI GPIB card for computer	National Instrument	C, P
Anritsu RF verification and calibration software		Anritsu 2300-497	C, P
Spectrum Analyzer	Frequency: 100 kHz to 50 GHz Resolution bandwidth: 10 Hz	Agilent 8565EC	C, P
Phase noise measurement system	Frequency range: 5 MHz to 26.5 GHz	Aeroflex/Comstron PN9000 with: PN9060-00 Status Module PN9470-00 Noise Output Module PN9450-00 Lock Control Module PN9342-00 Phase Detector Module PN9530-00 Crystal Oscillator Module or: Agilent Phase Noise Station: One K222B INSERTABLE F-F Anritsu One 34NKF50 N Male to K Female Adapter Anritsu One K241C Power Splitter Anritsu One SC3855 3670K50-2 KM-KM flex cable Anritsu One E5052B Signal Source Analyzer Agilent One E5053A Down Converter Agilent Two K120MM-20CM 2 Semi ridged cables K120MM0-20CM (will need to be bent on site to fit) Anritsu One Mouse, Optical, PS2/USB for E5052B One Keyboard USB for E5052B	P
Modulation analyzer	AM and FM measurement capability to > 500 MHz and -20 dBm	HP8901A	P

Table 1-1. Test Equipment List (Sheet 2 of 4)

Instrument	Critical Specification	Manufacturer/Model	Usage ⁽¹⁾
Frequency counter	For use in calibration and performance verification the critical specifications are: Frequency range: 0.01 to 20 GHz Input impedance: 50 Ω Resolution: 1 Hz Other: External time base input For use with only performance verification. Critical specifications are: Frequency range: 0.01 to 6 GHz Input impedance: 50 Ω Resolution: 1 Hz Other: External time base input	For calibration and performance verification the recommendation is Anritsu model MF2414B For performance verification the recommendation is Anritsu model MF2412B	C, P
Power meter	Frequency: 100 kHz to 67 GHz Power range: -70 to +20 dBm	Anritsu model ML2437A/38A	C, P
Power sensor for power meter	Frequency: 0.01 to 40 GHz (K) Power range: -70 to +20 dBm	Anritsu model MA2474D	C, P
Power sensor for power meter	Frequency: 0.01 to 50 GHz (V) Power range: -70 to +20 dBm	Anritsu model MA2475D	C, P
Power sensor for power meter	Frequency: 0.01 to 67 GHz (V) Power range: -30 to +20 dBm	Anritsu model SC7430 or Anritsu model SC7570	C, P
Power sensor for power meter	Frequency: 100 kHz to 18 GHz (N) Power range: -55 +20 dBm	Anritsu model SC7400	C, P
Adapter for power sensor SC7400	N female to K adapter	Anritsu model 34NFK50	C, P
Adapter for power sensor calibration	N(m) to K(f)	Anritsu 34NKF50	C, P
Adapters for power sensor calibration	N(m) to V(f)	Common source or Alternate to achieve N(m) to V(f): Anritsu model 34NK50 + 34VKF50 or Anritsu model 34NKF50 + 34VK50	C, P
Special AUX I/O cable assembly	Provides interface between the MG369xB and the power meter	Anritsu PN: 806-97	P
Digital multimeter	Minimum 1% RMS ACV accuracy at 100 kHz	Fluke 8840A	P
Function generator	Frequency: 0.1 Hz to 15 MHz	Agilent 33120A	C, P
Digital sampling oscilloscope	Frequency: 50 GHz	Agilent 86100A with 83484A 50 GHz module	P
Frequency reference	Frequency: 10 MHz Accuracy: 5×10^{-12} parts/day	Absolute Time Corp., model 300 or Symmetricom (Datum) model 9390-9600	P

Table 1-1. Test Equipment List (Sheet 3 of 4)

Instrument	Critical Specification	Manufacturer/Model	Usage ⁽¹⁾
Measuring receiver ⁽²⁾	Noise floor: < -140 dBm @ 500 MHz	Anritsu model ML2530A	C, P
Local oscillator	Frequency: 0.01 to 40 GHz	Anritsu Model MG3694B with options: 3, 4, 16, and SM6191 (unit can not have options 2B, 15B or 22) Note: If the T2579 mixer box is ordered, then special SM6191 must be added to the LO.	C, P
Mixer	Frequency range: 500 MHz to 40 GHz Conversion loss: 10 dBm (typical)	Anritsu PN: 60-114	P
M to M Adapter	K(m) to K(m)	Anritsu P/N K220B	P
Mixer box ⁽²⁾ (for low level calibration)	Frequency range: 0.01 GHz to 40 GHz	Anritsu PN: T2579	C, P
Low pass filter (Qty = 2) ⁽²⁾	1.9 GHz LPF	Mini-Circuits BPL-1.9 or Anritsu PN: 1030-104	C, P
Scalar network analyzer with RF detector	Frequency: 0.01 to 40 GHz	Anritsu model 56100A with RF detector: 560-7K50 (0.01 to 40 GHz) or 560-7VA50 (0.01 to 50 GHz)	C, T
AUX I/O interface cable	Provides interface between the instrument under test and the 56100A Scalar Network Analyzer	Anritsu PN: 806-7	C
Attenuator for instrument model numbers MG3691B through MG3694B	Frequency range: DC to 40 GHz Attenuation: 3, 6, 10, and 20 dB (sizes and counts are determined depending on options and maximum output power of instrument)	Anritsu part number SC7879 K set of attenuators (41KC-3, 41KC-6, 41KC-10, 41KC-20) calibrated from 100 K to 40 GHz or Anritsu, model 41KC-3, 41KC-6, 41KC-10 or 41KC-20 calibrated at the following data points: 100 kHz, 1 MHz, 10 MHz, 100 MHz, 500 MHz to 40 GHz in 500 MHz steps	C, P
Attenuator for instrument model numbers MG3695B through MG3696B	Frequency Range: DC to 65 GHz Attenuation: 3, 6, 10, and 20 dB (sizes and counts are determined depending on options and maximum output power of instrument)	Anritsu part number SC7880 V set of attenuators (41V-3, 41V-6, 41V-10, 41V-20) calibrated from 100 K to 67 GHz. or Anritsu, model 41V-3, 41V-6, 41V-10 and 41V-20 calibrated at the following data points: 100 kHz, 1 MHz, 10 MHz, 100 MHz, 500 MHz to 67 GHz in 500 MHz steps	C, P
BNC Tee	Connectors: 50 Ω BNC	Any common source	C, P
Generic 50 Ω BNC RF cables and connectors		Any common source	C, P
Generic GPIB cables		Any common source	C, P
BNC to SMA adapter	BNC to SMA Adapter	Any common source	P

Table 1-1. Test Equipment List (Sheet 4 of 4)

Instrument	Critical Specification	Manufacturer/Model	Usage⁽¹⁾
K(m) to K(m) flex cables or semi-rigid cables	K(m) to K(m) flex cables or Semi-rigid cables	Anritsu SC3855 3670K50-2 K(m) to K(m) flex cable or Anritsu K120mm-60CM custom semi-rigid cable	C, P
V(m) to V(m) flex cables or semi-rigid cables	V(m) to V(m) flex cables or Semi-rigid cables	Anritsu APN 3670V50-2 V(m) to V(m) flex cable or Anritsu V120mm-60CM Custom Semi-rigid cable	C, P
Anritsu Cal Data Save/Recall software		Anritsu P/N 2300-478	C
Special Serial I/O Cable Assembly	Provides interface between the MG3690B and the PC	Anritsu P/N: T1678	C ,P

1. P = Performance Verification Tests, C = Calibration, T = Troubleshooting

2. Only needed if option 2X is installed.

Chapter 2 — Functional Description

2-1 Introduction

This chapter provides brief functional descriptions of the major subsystems that are contained in each model of the MG369xB. In addition, the operation of the frequency synthesis, automatic level control (ALC), and RF deck subsystems is described so that the instrument operator may better understand the overall operation of the MG369xB. Block diagrams are included to supplement the written descriptions.

2-2 Major Subsystems

The MG369xB circuitry consists of various distinct subsystems that are contained on one or more printed circuit board (PCB) assemblies or in microwave components located on the RF deck. The following paragraphs identify the subsystems that make up the instrument and provide a brief description of each. [Figure 2-1 on page 2-4](#) is an overall block diagram of a typical MG369xB synthesizer.

Digital Control

This circuit subsystem consists of the A2 Microprocessor PCB. The central processor unit (CPU) located on this PCB is the main controller for the MG369xB. This controller directly or indirectly controls all functions of the instrument. The CPU contains memory that stores the main operating system components and instrument firmware, instrument calibration data, and front panel setup data during the power-off condition. It has a GPIB interface that allows it to communicate with external devices over the GPIB and a serial interface to a serial terminal port on the rear panel. The CPU is directly linked via a dedicated data and address bus to the front panel assembly, the A5 Auxiliary/Analog Instruction PCB, the A6 ALC PCB, the A7 YIG-lock PCB, and the A9 YIG assembly.

Interface circuits on the A2 PCB indirectly link the CPU to the A3 reference/fine loop PCB, and the A4 coarse loop PCB. The A2 PCB contains circuits that perform parallel-to-serial and serial-to-parallel data conversion. The A2 also contains circuitry for many of the rear panel signals and a 14-bit resolution digital volt meter (DVM).

Front Panel Assembly

This circuit subsystem consists of the front panel, the front panel rotary data knob, the front panel control PCB, and the liquid crystal display (LCD). The subsystem interfaces the front panel LCD, light emitting diodes (LEDs), and keys to the CPU via the dedicated data and address bus. The front panel rotary data knob is also linked to the CPU via the data and address bus.

The front panel PCB contains the keyboard matrix conductive rubber switches. It has circuits to control the LCD, turn the front panel LEDs on and off, and convert keyboard switch matrix signals to parallel key code. It also contains the standby/operate line switch and the optical encoder for the rotary data knob.

Frequency Synthesis

The frequency synthesis subsystem consists of the A3 reference/fine loop PCB, the A4 coarse loop PCB, the A7 YIG lock PCB, and the A9 YIG assembly. It provides the reference frequencies and phase lock circuits for precise control of the YIG-tuned oscillator frequencies, as follows:

- The reference loop circuitry located on the A3 PCB supplies the stable 10 MHz and 500 MHz reference frequency signals for the rest of the frequency synthesis system.
- The A4 coarse loop PCB generates coarse tuning frequencies of 219.5 to 245 MHz for use by the YIG lock PCB.
- The fine loop circuitry located on the A3 PCB provides fine tuning frequencies of 21.5 to 40 MHz for use by the YIG lock PCB.
- The A7 YIG lock PCB performs phase detection of the YIG-tuned oscillator's output frequency and provides a YIG loop error voltage signal. This error signal is further conditioned, producing a correction signal that is used to fine tune and phase lock the YIG-tuned oscillator.

The CPU sends control data to the A3 reference/fine loop PCB and the A4 coarse loop PCB as serial data words. Refer to [Section 2-3](#) for a functional overview of the frequency synthesis subsystem.

A9 YIG Assembly

The A9 YIG assembly contains the YIG-tuned oscillator and associated PCB assembly. The PCB assembly contains the driver circuitry that provides the tuning current and bias voltages for the YIG-tuned oscillator. The Bias controls for the A9 YIG assembly are supplied by the A6 ALC Board. The CPU controls the A9 YIG assembly via the serial bus.

ALC/AM/Pulse Modulator

This ALC circuit subsystem consists of the A6 ALC PCB, the A6A1 AM module, output coupler and switched filter. It provides the following:

- Level control of the RF output power
- Current drive signals to the PIN switches located in the A10 switched filter assembly (SWF), the A12 switched doubler module (SDM), and the source quadrupler module (SQM)
- Drive signals for the step attenuator (Option 2) and the diplexers (used with Option 22)

The CPU controls the A6 ALC PCB (and the A6A1 AM module via the A6 PCB) via the dedicated data and address bus. Refer to [Section 2-4](#) for a functional overview of the ALC subsystem.

RF Deck

This subsystem contains those elements related to the generation, modulation, and control of the sweep- and CW-frequency RF signals. These elements include the A9 YIG-tuned oscillator/PCB assembly, the 0.01 to 2 GHz down converter assembly (A11), the A10 switched filter assembly, the A12 switched doubler module, the source quadrupler module, the directional coupler/level detector, and the optional step attenuator. Refer to [Section 2-5](#) for a functional overview of the RF deck subsystem.

Power Supply

The power supply subsystem consists of the power input connector/filter module, the regulator PCB, the power supply PCB, the standby power supply PCB, and the power module fan unit. It supplies all the regulated DC voltages used by the MG369xB circuits. The voltages are routed throughout the instrument via the motherboard PCB.

Inputs/Outputs

The A21 rear panel PCB and the A2 microprocessor PCB contain the interface circuits for the majority of the rear panel input and output connectors, including the AUX I/O connector.

The A5 Auxiliary PCB (or the optional A5 Analog Instruction PCB) provides a 0V to +10V ramp signal to the rear panel HORIZ OUT connector, a V/GHz signal to the rear panel AUX I/O connector, and a SLOPE signal to the A6 ALC PCB for slope-vs-frequency correction of the RF output power.

The rear panel EXT ALC IN, AM IN, and AM OUT are routed through the A21 rear panel PCB and then through the motherboard PCB to the A6 ALC PCB. The rear panel connectors, 10 MHz REF OUT and 10 MHz REF IN, are routed through the A21 PCB and coupled to the A3 Reference/Fine Loop PCB via coaxial cables.

The rear panel FM/ Φ M IN and FM/ Φ M OUT connectors are routed through the A21 rear panel PCB, and then through the Motherboard PCB to the A7 YIG-lock PCB. The rear panel PULSE TRIG IN connector is routed through the A21 rear panel PCB, and then to the A6 ALC PCB (or optional Pulse Generator PCB, if installed). The rear panel PULSE SYNC OUT and PULSE VIDEO OUT connectors are routed through the A21 rear panel PCB and then to the optional Pulse Generator PCB via coaxial cables. The rear panel EFC IN connector is routed to the A3 Reference/Fine Loop PCB via coaxial cables.

The rear panel IEEE-488 GPIB and SERIAL I/O connectors are routed through the A21 rear panel PCB and then through the motherboard to the A2 microprocessor PCB.

Motherboard/Interconnections

The motherboard PCB and associated cables provide the interconnections for the flow of data, signals, and DC voltages between all internal components and assemblies throughout the MG369xB.

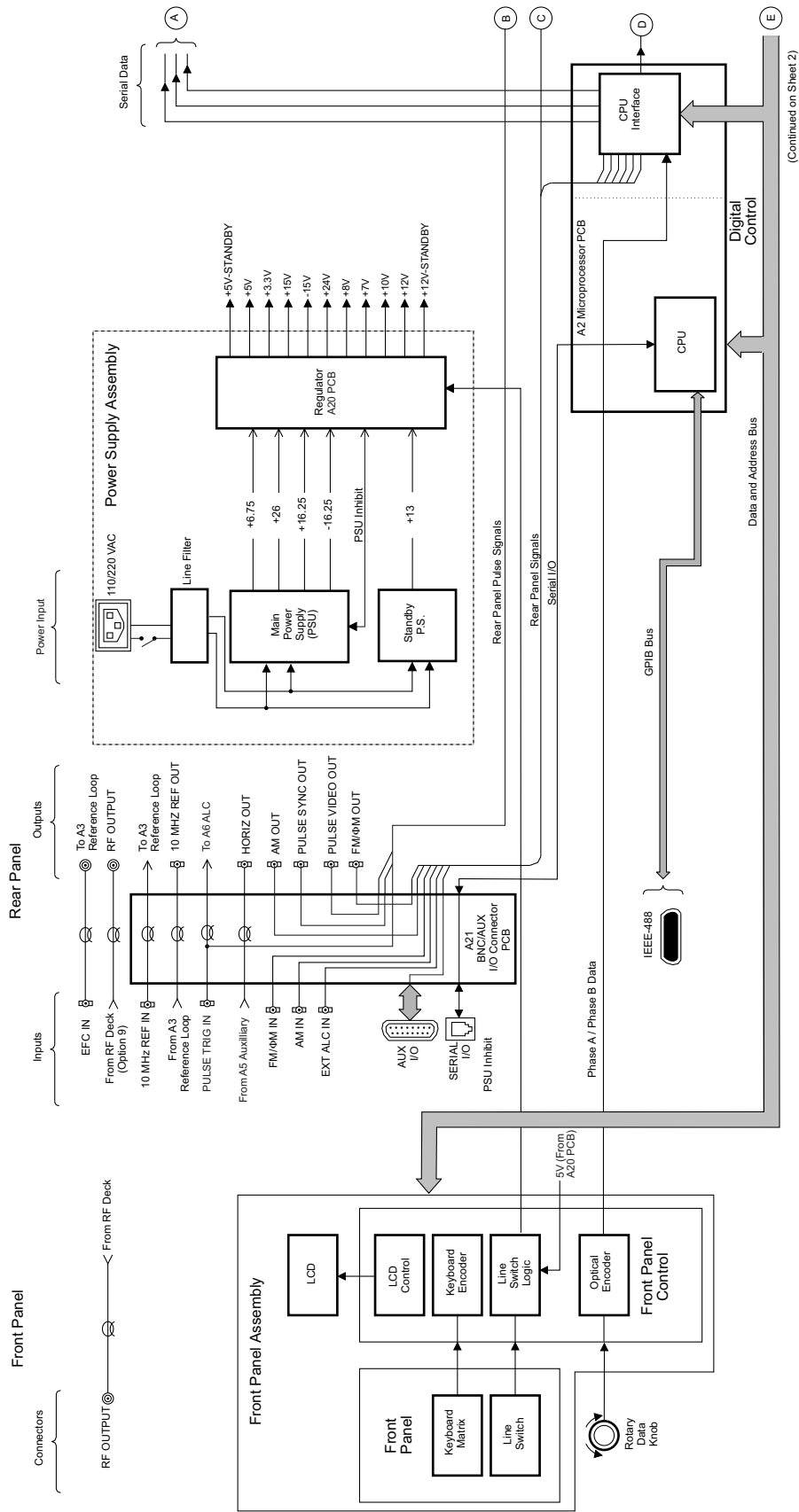
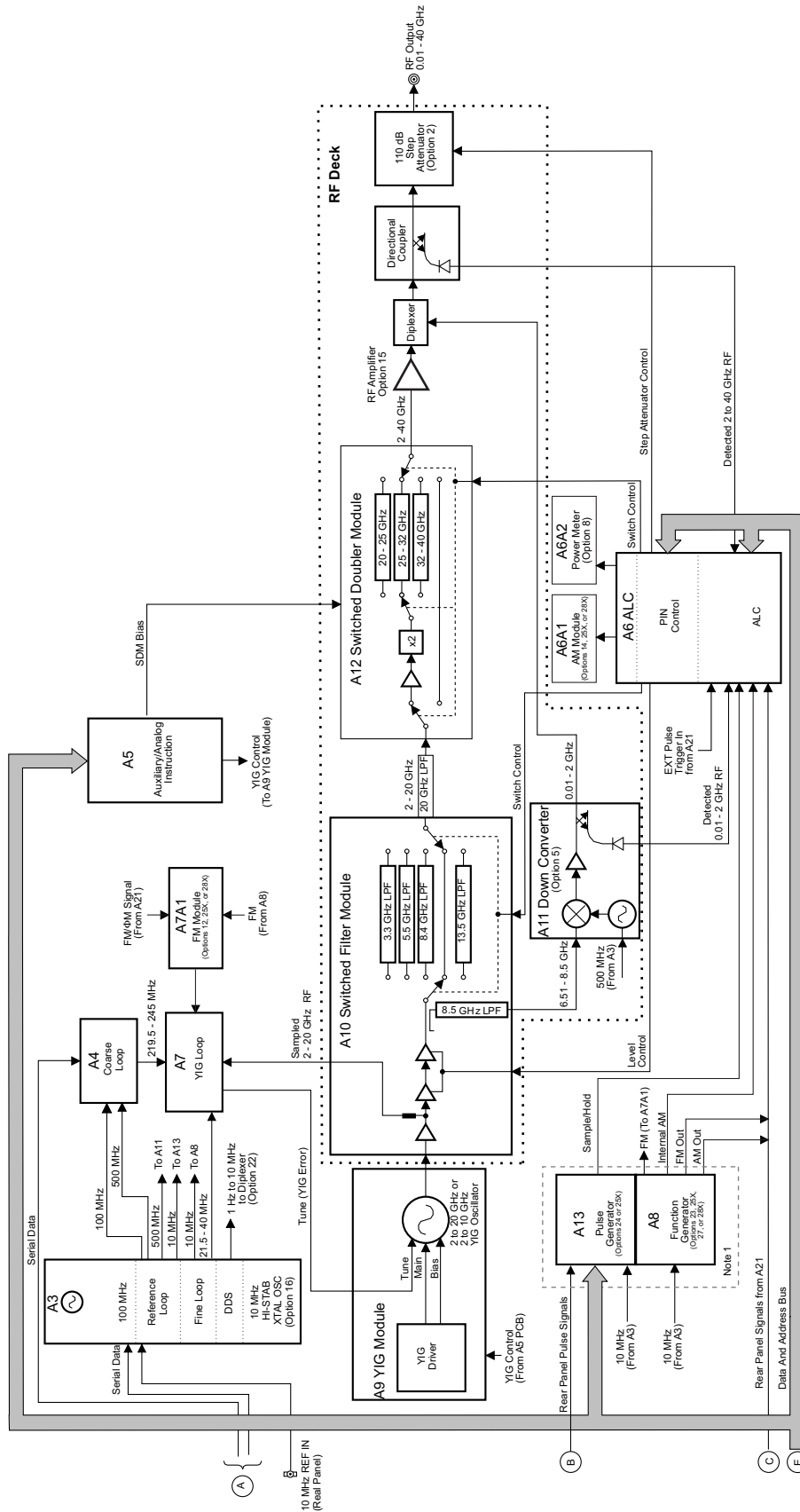

Figure 2-1. Block Diagram of a Typical MG369xB Synthesized Signal Generator (Sheet 1 of 2)



Note 1: On units with option 27 or option 28x the A8 and A13 are combined into a single PCB controlled by the data and address bus (E).

(Continued From Sheet 1)

Figure 2-1. Block Diagram of a Typical MG369xB Synthesized Signal Generator (Sheet 2 of 2)

2-3 Frequency Synthesis

The frequency synthesis subsystem provides phase-lock control of the MG369xB output frequency. It consists of four phase-lock loops, the reference loop, the coarse loop, the fine loop, and the YIG loop. The four phase-lock loops, operating together, produce an accurately synthesized, low-noise RF output signal. [Figure 2-2 on page 2-7](#) is an overall block diagram of the frequency synthesis subsystem. The following paragraphs describe phase-lock loops and the overall operation of the frequency synthesis subsystem.

Phase Lock Loops

The purpose of a phase-lock loop is to control the frequency of a variable oscillator in order to give it the same accuracy and stability as a fixed reference oscillator. It works by comparing two frequency inputs, one fixed and one variable, and supplying a correction signal to the variable oscillator to reduce the difference between the two inputs. For example, suppose we have a 10 MHz reference oscillator with a stability of 1×10^{-7} /day, and we wish to transfer that stability to a voltage controlled oscillator (VCO). The 10 MHz reference signal is applied to the reference input of a phase-lock loop circuit. The signal from the VCO is applied to the variable input. A phase detector in the phase-lock loop circuit compares the two inputs and determines whether the variable input waveform is leading or lagging the reference. The phase detector generates a correction signal that (depending on polarity) causes the VCO frequency to increase or decrease to reduce any phase difference. When the two inputs match, the loop is said to be *locked*. The variable input from the VCO then equals the reference input in phase, frequency, accuracy, and stability.

In practical applications a frequency divider is placed between the output of the variable oscillator and the variable input to the phase-lock loop. The circuit can then be used to control a frequency that is an exact multiple of the reference frequency. In this way, the variable oscillator acquires the stability of the reference without equaling its frequency. In the A3 reference loop, the 100 MHz VCXO can be controlled by the phase-lock loop using a 10 MHz reference. This is because a divide-by-ten circuit is between the VCXO's output and the variable input to the phase-lock loop. Both inputs to the phase detector will be 10 MHz when the loop is locked.

If a programmable frequency divider is used, a number of frequencies can be phase-locked to the same reference. The limitation is that all must be exact multiples of the reference. The A4 coarse loop and A3 fine loop section both use programmable frequency dividers.

Overall Operation

The YIG-tuned oscillator generates a high-power RF output signal that has low broadband noise and low spurious content. The frequency of the YIG-tuned oscillator is controlled by means of (1) its main tuning coil and (2) its FM (fine tuning) coil. The main tuning coil current from the YIG-driver PCB coarsely tunes the YIG-tuned oscillator to within a few megahertz of the final output frequency. The YIG phase-lock loop is then used to fine tune the YIG-tuned oscillator to the exact output frequency and to reduce FM noise close to the carrier.

One input to the YIG loop is the 219.5 to 245 MHz signal from the coarse loop. This signal is amplified to drive the step-recovery diode (located on the A7 PCB). The step-recovery diode produces harmonics of the coarse loop signal (≥ 1.9755 to > 20 GHz). These harmonics are used by the sampler.

The other input to the sampler is a sampled RF output signal from the YIG-tuned oscillator. Mixing this RF output signal sample with the adjacent coarse-loop harmonic produces a low frequency difference signal that is the 21.5 to 40 MHz YIG IF signal.

The MG369xB CPU programs the coarse-loop oscillator's output frequency so that one of its harmonics will be within 21.5 to 40 MHz of the desired YIG-tuned oscillator's output frequency. The YIG loop phase detector compares the YIG IF signal to the 21.5 to 40 MHz reference signal from the fine loop. If there is a difference, the YIG phase detector fine tunes the YIG-tuned oscillator (via the FM circuitry and the FM coil drivers) to eliminate any frequency difference between the two signals.

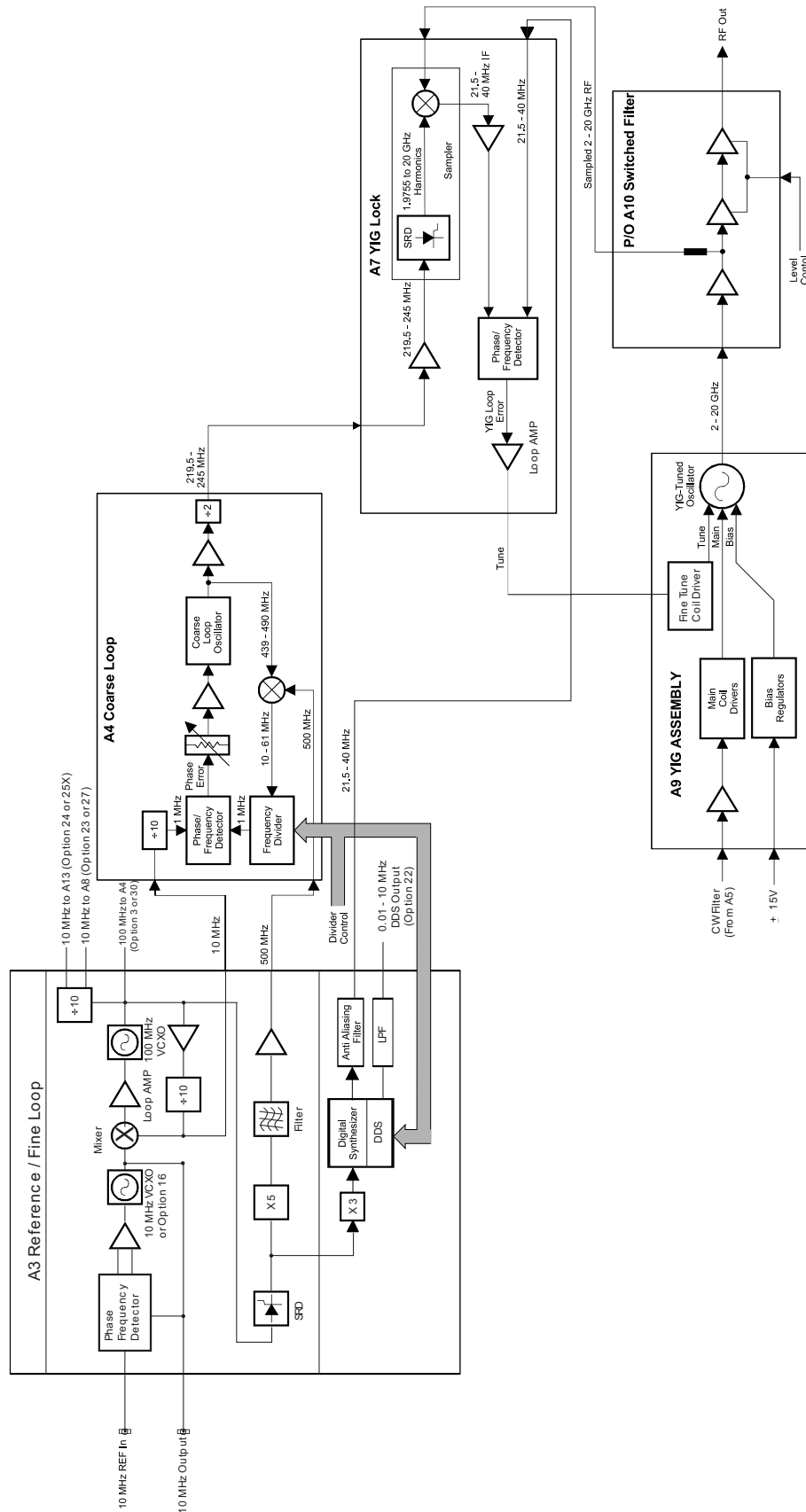

Figure 2-2. Block Diagram of the Frequency Synthesis Subsystem

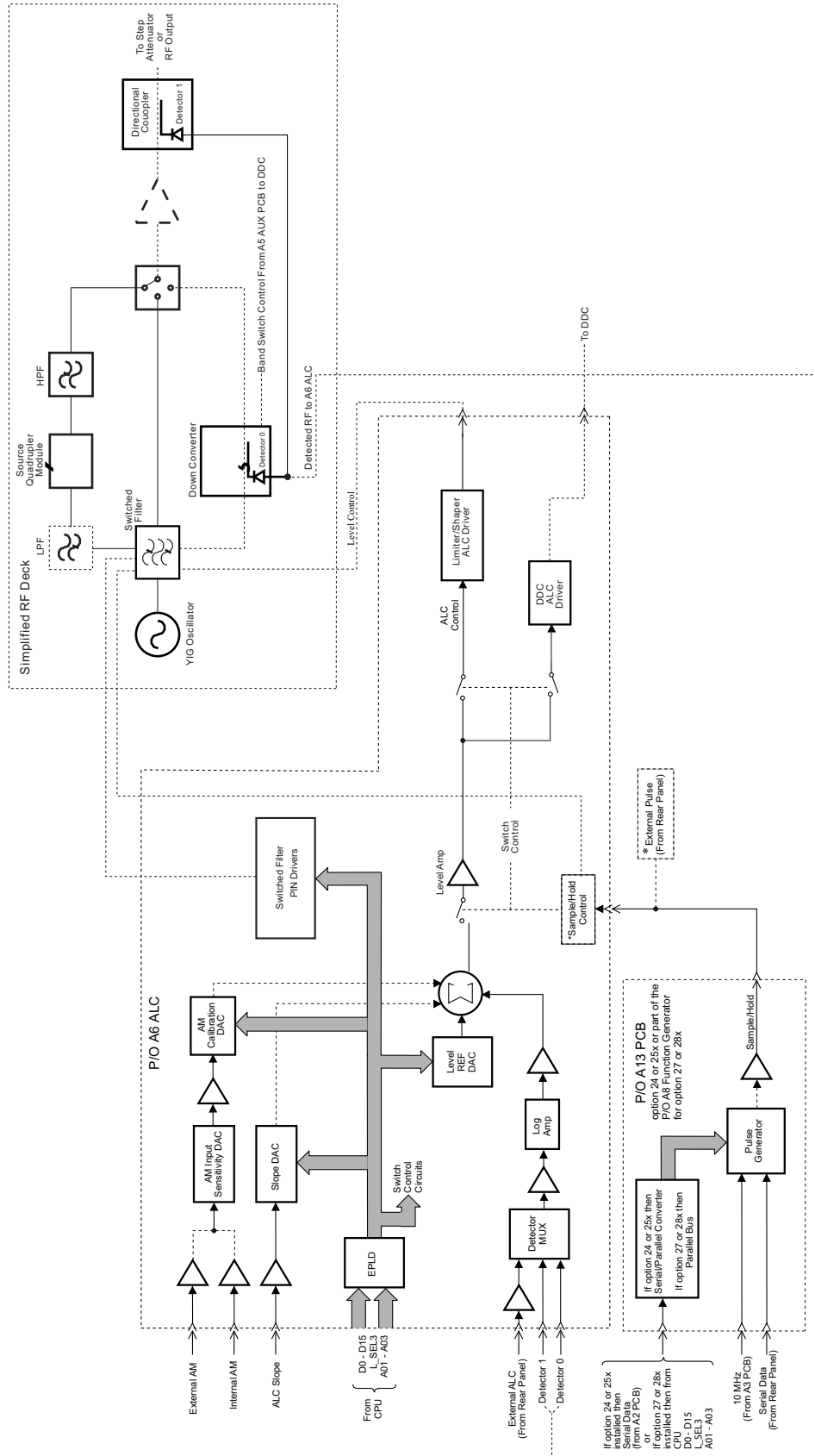

Figure 2-3. Block Diagram of the ALC Subsystem

Phase locking the instrument's output frequency over a broad frequency range is accomplished by programming the coarse-loop oscillator's output to various frequencies that have harmonics close to the desired operating frequencies. Exact frequency tuning for each desired operating frequency is accomplished by programming the fine-loop oscillator. In each case, the YIG-tuned oscillator is first tuned via the main tuning coil to the approximate desired operating frequency. Table 2-1 shows the coarse-loop and fine-loop frequencies for specific RF output frequencies.

The coarse-loop oscillator has a programming (tuning) range of 219.5 to 245 MHz and a resolution of 1 MHz. This provides harmonics from ≥ 1.9755 GHz to > 20 GHz. This allows any YIG-tuned oscillator output frequency to be down converted to a YIG IF signal of 21.5 to 40 MHz.

The YIG loop is fine tuned by varying the 21.5 to 40 MHz reference signal applied to the YIG loop phase detector. By programming the fine-loop oscillator, this signal can be adjusted in 0.01 Hz increments over the 21.5 to 40 GHz range. The resolution of the fine-loop oscillator (hence the resolution of the RF output signal) is 0.01 Hz, which is much finer than is available from the coarse loop alone.

The coarse loop and fine loop outputs are derived from high-stability 10 MHz and 500 MHz signals generated by the A3 reference loop. For applications requiring even greater stability, the 100 MHz oscillator can be phase locked to an optional 10 MHz high stability reference (internal or external).

Table 2-1. RF Output and Loop Frequencies

RF Out in MHz	Coarse Loop in MHz		Fine Loop in MHz	
	Standard	Opt. 3	Standard	Opt. 3
2000	234.7	212.5	22	40
3000	229	217.1	23	40
4000	234	212.6	22	40
5000	237	420	23	40
6000	239	464.6	25	40
7000	240.5	469.3	25.5	40
8000	241.5	472.9	30.5	40
9000	242.5	821.8	27.5	40
10000	243	836.7	37	40
11000	238.5	849.2	29	40
12000	239.5	926.2	25	40
13000	240	869.33	40	40
14000	245	877.5	35	40
15000	241.5	940	27	40
16000	242	943.5	28	40
17000	242.5	946.7	25	40
18000	239.5	859.1	37.5	40
19000	240	865.5	40	40
20000	243.5	871.3	33	40

RF Outputs 0.01 MHz to 65 or 67 GHz

Refer to the block diagrams of the RF Deck shown in [Figure 2-4 on page 2-17](#) through [Figure 2-15 on page 2-28](#) for the following descriptions. The MG369xB uses one YIG-tuned oscillator capable of generating RF signals in the frequency range of 2.0 to 20 GHz (the MG3691B YIG-tuned oscillator generates RF signals in the frequency range of 2.0 to 10.0 GHz). All other frequencies output by the instrument, except for 0.1 Hz to 10 MHz (Option 22) are derived from the fundamental frequencies generated by the YIG-tuned oscillator.

0.1 Hz to 10 MHz (Option 22)

Output frequencies of 0.1 Hz to 10 MHz are produced by models with Option 22. The 0.1 Hz to 10 MHz signal is generated by a direct digital synthesizer (DDS) located on the A3 PCB. Precise control of the output frequencies to a 0.1 Hz resolution is achieved by phase-lock control of the 300 MHz signal generated by the fine loop circuitry on the A3 PCB.

0.01 to 2.2 GHz (Option 4)

RF output frequencies of 0.01 to 2.2 GHz are developed by down converting the fundamental frequencies of 2 to 4.4 GHz. This is achieved by using a series of dividers and 16 bandpass filters. Precise control of the 0.01 to 2.2 GHz frequencies to 0.01 Hz resolution is achieved through phase-lock control of the fundamental frequencies prior to division.

0.01 to 2 GHz (Option 5)

RF output frequencies of 0.01 to 2 GHz are developed by down converting the fundamental frequencies of 6.51 to 8.5 GHz. This is achieved by mixing the fundamental RF output with a 6.5 GHz local oscillator signal that is phase locked to the 500 MHz output of the reference loop. Precise control of the 0.01 to 2 GHz frequencies to 0.01 Hz resolution is accomplished by phase-lock control of the 6.51 to 8.5 GHz fundamental frequencies prior to down conversion.

20 to 30 GHz (Model MG3693B)

RF output frequencies of 20 to 30 GHz are produced by doubling the 10 to 15 GHz fundamental frequencies. Phase-lock control of the 10 to 15 GHz fundamental frequencies, accomplished prior to doubling, ensures precise control of the 20 to 30 GHz frequencies to 0.01 Hz resolution.

20 to 40 GHz (Model MG3694B)

RF output frequencies of 20 to 40 GHz are produced by doubling the 10 to 20 GHz fundamental frequencies. Phase-lock control of the 10 to 20 GHz fundamental frequencies, accomplished prior to doubling, ensures precise control of the 20 to 40 GHz frequencies to 0.01 Hz resolution.

40 to 50 GHz (Model MG3695B)

RF output frequencies of 40 to 50 GHz are produced by quadrupling the 10 to 12.5 GHz fundamental frequencies. Phase-lock control of the 10 to 12.5 GHz fundamental frequencies is accomplished prior to doubling. This ensures precise control of the 40 to 50 GHz frequencies to a 0.01 Hz resolution.

40 to 65 or 67 GHz (Model MG3696B)

RF output frequencies of 40 to 65 or 67 GHz are produced by quadrupling the 10 to 16.8 or 17.5 GHz fundamental frequencies. Phase-lock control of the 10 to 16.8 or 17.5 GHz fundamental frequencies is accomplished prior to doubling. This ensures precise control of the 40 to 65 or 67 GHz frequencies to a 0.01 Hz resolution.

Table 2-2. Digital Down Converter Frequency Bands

Band	Frequency Range (in MHz)
0	10 to 12.5
1	12.5 to 17.5
2	17.5 to 22.5
3	22.5 to 31.25
4	31.25 to 43.75
5	43.75 to 62.5
6	62.5 to 87.5
7	87.5 to 125
8	125 to 175
9	175 to 250
10	250 to 350
11	350 to 500
12	500 to 700
13	700 to 1050
14	1050 to 1500
15	1500 to 2200

Frequency Modulation

Frequency modulation (FM) of the YIG-tuned oscillator RF output is achieved by summing an external or internal modulating signal into the FM control path of the YIG loop (refer to [Figure 2-1](#) and [Figure 2-2](#)).

The external modulating signal comes from the rear panel FM/ Φ M IN input connector; the internal modulating signal comes from the A8 Function Generator PCB. Circuits on the A7A1 FM Module adjust the modulating signal for the FM sensitivity selected, then sum it into the YIG loop FM control path. There, it frequency modulates the RF output signal by controlling the YIG-tuned oscillator's FM (fine tuning) coil current.

Phase Modulation

Phase modulation (Φ M) of the YIG-tuned oscillator RF output is achieved by summing an external or internal modulating signal into the FM control path of the YIG loop. The external modulating signal comes from the rear panel FM IN/ Φ M IN input connector; the internal modulating signal comes from the A8 Function Generator PCB.

Circuits on the A7A1 FM Module adjust the modulating signal for the Φ M sensitivity selected, convert the modulating signal to a Φ M signal by differentiation, and then sum it into the YIG loop FM control path. There, it phase modulates the RF output signal by controlling the YIG-tuned oscillator's FM (fine tuning) coil current.

Analog Sweep Mode

Broad-band analog frequency sweeps (> 100 MHz wide) of the YIG-tuned oscillator RF output are accomplished by applying appropriate analog sweep ramp signals, generated by the A5 Analog Instruction PCB, to the YIG-tuned oscillator's main tuning coil. In this mode, the start, stop, and band switching frequencies are phase-lock-corrected during the sweep.

Note

For instruments with Option 4 at frequencies of ≤ 2.2 GHz, broad-band analog frequency sweeps are > 25 MHz wide; narrow-band analog frequency sweeps are ≤ 25 MHz.

Narrow-band analog frequency sweeps (≤ 100 MHz wide) of the YIG-tuned oscillator RF output are accomplished by summing appropriate analog sweep ramp signals, generated by the A5 Analog Instruction PCB, into the YIG-tuned oscillator's FM tuning coil control path. The YIG-tuned oscillator's RF output is then swept about a center frequency. The center frequency is set by applying a tuning signal (also from the A5 PCB) to the YIG-tuned oscillator's main tuning coil. In this mode, YIG loop phase locking is disabled except during center frequency correction, which occurs during sweep retrace.

Step Sweep Mode

Step (digital) frequency sweeps of the YIG-tuned oscillator RF output consist of a series of discrete, synthesized steps between a start and stop frequency. Each frequency step is generated by applying the tuning signal (from the A9 module PCB) to the YIG-tuned oscillator's main tuning coil, then phase-locking the RF output. Every frequency step in the sweep range is phase-locked.

2-4 ALC/AM/Pulse Modulation

The MG369xB ALC, AM, and pulse modulation subsystems provide automatic level control (ALC), amplitude modulation (AM), and pulse modulation of the RF output signal. The ALC loop consists of circuits located on the A6 ALC PCB, and the A9 YIG PCB assembly. These circuits interface with the A10 switched filter assembly, the A11 down converter assembly and the directional coupler/level detector (all located on the RF deck). AM circuits located on the A6 ALC PCB and A6A1 AM Module are also included in this loop. Pulse modulation of the RF output signal is provided by circuits on the A6 ALC PCB. These circuits interface directly with the switched filter assembly located on the RF deck via coaxial cables. (In instruments with Option 4, these circuits interface directly with the digital down converter and are looped through the digital down converter to the switched filter assembly.)

The ALC subsystem is shown in [Figure 2-3 on page 2-8](#). The following paragraphs describe the operation of the subsystem components.

ALC Loop Operation

In the MG369xB, a portion of the RF output is detected and coupled out of the directional coupler/level detector as the feedback input to the ALC loop. The feedback signal from the detector is routed to the A6 ALC PCB where it is compared with a reference voltage that represents the desired RF power output level. If the two voltages do not match, an error correction signal is fed to the modulator shaper amplifier circuits located on the A6 PCB. The resulting ALC control voltage output causes the level control circuits, located on the A10 switched filter assembly, to adjust the RF output level. Thus, the feedback signal voltage from the level detector will be set equal to the reference voltage.

Note

The instrument uses two internal level detection circuits. For frequencies < 2 GHz, the level detector is part of the down converter. The signal from this detector is routed to the A6 ALC PCB as the Detector 0 input. For frequencies ≥ 2 GHz, the level detector is part of the main directional coupler. The signal from this detector is routed to the A6 ALC PCB as the Detector 1 input.

The level reference DAC, under the control of the CPU, provides the RF level reference voltage. By setting the output of this DAC to the appropriate voltage, the CPU adjusts the RF output power to the level selected by the user.

External Leveling

In the external leveling mode, an external detector or power meter monitors the RF output level of the MG369xB instead of the internal level detector. The signal from the external detector or power meter goes to the A6 ALC PCB assembly from the rear panel input. The ALC controls the RF power output level as previously described.

ALC Slope

During analog sweeps, a slope-vs-frequency signal, from the A5 Analog Instruction PCB, is summed with the level reference and detector inputs into the ALC loop. The Slope DAC, under the control of the CPU, adjusts this ALC slope signal to compensate for an increasing or decreasing output power-vs-frequency characteristic caused by the level detectors and (optional) step attenuator. In addition, the Slope DAC lets the user adjust for the slope-vs-frequency characteristics of external components.

Power Sweep

In this mode, the CPU has the ALC step the RF output through a range of levels specified by the user. This feature can be used in conjunction with the sweep mode to produce a set of identical frequency sweeps, each with a different RF power output level.

Amplitude Modulation

Amplitude modulation (AM) of the RF output signal is accomplished by summing an external or internal modulating signal into the ALC loop. External modulating signals come from the rear panel AM IN inputs, the internal modulating signal comes from the A8 Function Generator PCB.

The AM Input Sensitivity DAC and the AM Calibration DAC, under the control of the CPU, adjust the modulating signal for the proper amount of AM in both the linear and the log modes of operation. The adjusted modulating signal is summed with the level reference, slope, and detector inputs into the ALC loop. This produces an ALC control signal that varies with the modulating signal. The action of the ALC loop then causes the envelope of the RF output signal to track the modulation signal.

Pulse Modulation Operation

During pulse modulation, the ALC level amplifier (A6 ALC PCB) is operated as a sample/hold amplifier. The level amplifier is synchronized with the modulating pulses from the A8 Function Generator or A13 Pulse Generator PCB so that the ALC loop effectively operates only during the ON portion of the pulsed modulated RF output.

Pulse Generator Operation

The A8 Function Generator or A13 Pulse Generator PCB provides the internal pulse generating function for the MG369xB. It also interfaces external pulse inputs from the rear panel connector to the pulse modulator driver in the external mode.

The pulse generator produces a pulse modulation waveform consisting of single, doublet, triplet, or quadruplet pulse trains at variable pulse rates, widths, and delays. It operates at two selectable clock rates — 10 MHz and 40 MHz for units with option 24 or 25x or 10 MHz and 100 MHz for unit with option 27 or 28x. In addition, the pulse generator produces a sync pulse and video pulse output that goes to the rear panel and a sample/hold signal that goes to the A6 ALC PCB. The sync pulse output is for synchronizing auxiliary instruments to the internally generated pulse; the video pulse is a TTL level copy of the RF output pulse; and the sample/hold signal synchronizes the ALC loop to the ON portion of the pulse modulating waveform.

The MG369xB has five pulse modulation modes:

- Internal pulse modulation mode—The pulse modulation waveform is generated and timed internally.
- External pulse mode—The external pulse source signal from the rear panel connectors is interfaced by the pulse generator to the pulse modulation driver.
- External triggered mode—The pulse generator is triggered by the external pulse source signal to produce the pulse modulation waveform.
- External gated mode—The external pulse source signal gates the internal pulse generator on and off.
- Composite mode—The external pulse source signal triggers the internal pulse generator and also modulates the RF output signal. The pulse generator produces a delayed, single pulse waveform that also modulates the RF output signal.

2-5 RF Deck Assemblies

The primary purpose of the RF deck assembly is to generate CW RF signals and route these signals to the front panel RF OUTPUT connector. It is capable of generating RF signals in the frequency range of 0.01 to 65 or 67 GHz (0.1 Hz to 65 or 67 GHz with Option 22).

The series MG369xB use a single YIG-tuned oscillator. All other frequencies (except for 0.1 Hz to 10 MHz), are derived from the fundamental frequencies generated by this oscillator, as follows:

- RF output frequencies of 0.1 Hz to 10 MHz (Option 22) are generated by the A3 Reference Loop PCB.
- RF output frequencies of 0.01 to 2 GHz are developed by down converting the fundamental frequencies of 6.51 to 8.5 GHz.
- RF output frequencies of 2 to 20 GHz are produced directly from the YIG-tuned Oscillator.
- RF output frequencies of 20 to 30 GHz are produced by doubling the fundamental frequencies of 10 to 15 GHz.
- RF output frequencies of 20 to 40 GHz are produced by doubling the fundamental frequencies of 10 to 20 GHz.
- RF output frequencies of 40 to 50 GHz are produced by quadrupling the fundamental frequencies of 10 to 12.5 GHz.
- RF output frequencies of 40 to 65 or 67 GHz are produced by quadrupling the fundamental frequencies of 10 to 16.8 or 17.5 GHz.

RF Deck Configurations

All MG369xB RF deck assemblies contain a YIG-tuned oscillator, a switched filter assembly, and a directional coupler. Beyond that, the configuration of the RF deck assembly varies according to the particular instrument model and options installed.

Refer to the block diagrams in [Figure 2-4 on page 2-17](#) through [Figure 2-15 on page 2-28](#), which show the various RF deck configurations and include all of the common RF components found in the series MG369xB RF deck assemblies. Refer to these block diagram while reading the following paragraphs.

YIG-tuned Oscillator

There are two YIG-tuned oscillator configurations. The MG3691B uses a single-band, 2 to 10 GHz, YIG-tuned oscillator. All other MG369xB models use a dual-band, 2 to 20 GHz YIG-tuned oscillator. The dual-band YIG-tuned oscillator contains two oscillators—one covering the frequency range of 2.0 to 10.0 GHz and one covering the frequency range of 10.0 to 20.0 GHz. Both of these oscillators use a common internal amplifier.

The YIG-tuned oscillator generates RF output signals that have low broadband noise and low spurious content. It is driven by the main tuning coil current and bias voltages from the A9 YIG PCB assembly and the fine tuning coil current from the A7 YIG lock PCB. During CW mode, the main tuning coil current tunes the oscillator to within a few megahertz of the final output frequency. The phase-lock circuitry of the YIG loop then fine adjusts the oscillator's fine tuning coil current to make the output frequency exact.

RF Signal Filtering

The RF signal from the YIG-tuned oscillator is routed to the level control circuits located on the A10 switched filter assembly and then, via PIN switches, to switched low-pass filters. The PIN switch drive current signals are generated on the A6 ALC PCB and routed to the switch control input on the A10 assembly.

The switched low-pass filters provide rejection of the harmonics that are generated by the YIG-tuned oscillator. In MG369xB models, the 2 to 20 GHz RF signal from the level control circuits has four filtering paths and a through path. The four filtering paths are 3.3 GHz, 5.5 GHz, 8.4 GHz, and 13.5 GHz. Signals above 13.5 GHz are routed via the through path.

To generate RF signals from 0.01 to 2 GHz, the MG369xB couples the RF signal to the A11 down converter. A coupler in the A10 switched filter path provides this RF signal, which is routed through a 8.5 GHz low-pass filter to connector J3, and then to the down converter. The 0.01 to 2 GHz RF signal output from the down converter is routed back to the A10 assembly (connector J1) and then multiplexed through the same path to the switched filter output.

After routing through the appropriate path, the RF signal is multiplexed by the PIN switches and goes via a 20 GHz low-pass filter to the A10 switched filter assembly output connector J2. From J2, the RF signal goes to the input of the directional coupler (model MG3692B), the input connector J1 of the A11 switched doubler module (models MG3693B/4B), or to an amplifier if the instrument is fitted with Option 15.

Instruments fitted with option 15A, 15B, 15C, or 15D all use a fixed gain amplifier before the directional coupler.

For models with Option 22, the RF signal from J2 goes to either input connector A of the diplexers (≤ 20 GHz models) or the input connector J1 of the switched doubler module (> 20 GHz models).

0.01 to 2 GHz Down Converter (Option 5)

The 0.01 to 2 GHz down converter assembly (shown in [Figure 2-4](#)) contains a 6.5 GHz VCO that is phase-locked to the 500 MHz reference signal from the A3 reference loop PCB. The 6.5 GHz VCO's phase-lock condition is monitored by the CPU. The 6.5 GHz VCO is on at all times; however, the down converter amplifier is powered on by the A5 AUX PCB only when the 0.01 to 2 GHz frequency range is selected.

For models with Option 22 and without an optional step attenuator, the 0.01 to 2 GHz (0.01 to 2.2 GHz with Option 4) RF output of the down converter is diplexed with the 0.1 Hz to 10 MHz output of the A3 DDS section. The resulting 0.1 Hz to 2 GHz signal is then diplexed with the RF signal from the switched filter assembly (or switched doubler module for > 20 GHz models) into the RF path to the directional coupler.

During CW or step frequency operations in the 0.01 to 2 GHz frequency range, the 6.51 to 8.5 GHz RF signal output from J3 of the switched filter assembly goes to input connector J1 of the down converter. This signal is then mixed with the 6.5 GHz VCO signal resulting in a 0.01 to 2 GHz RF signal. The resultant RF signal is fed through a 2 GHz low-pass filter, then amplified and routed to the output connector J3. A portion of the down converter's RF output signal is detected, amplified, and coupled out for use in internal leveling. This detected RF sample is routed to the A6 ALC PCB.

The 0.01 to 2 GHz RF output from the down converter goes to input connector J1 of the switched filter assembly. There, the 0.01 to 2 GHz RF signal is multiplexed into the switched filter's output.

0.01 to 2.2 GHz Digital Down Converter (Option 4)

The 0.01 to 2.2 GHz digital down converter assembly maintains the same basic functionality and control as the 0.01 to 2 GHz down converter. During CW or step frequency operations in the 0.01 to 2.2 GHz frequency range, a 2 to 4.4 GHz RF signal output from J3 of the switched filter assembly goes to the input connector J1 of the down converter.

This signal is then down converted through a series of dividers resulting in a 0.01 to 2.2 GHz RF signal output. The resultant RF signal is fed through a series of band-pass filters, then detected, amplified, and coupled out for use in internal leveling before being routed to the output connector J3. The detected RF sample is routed to the A6 ALC PCB. Digital control signals from the A2 CPU PCB are routed through the A5 auxiliary PCB.

Switched Doubler Module

The A11 switched doubler module is used on all MG369xB models with RF output frequencies > 20 GHz. Model MG3693B uses an SDM to double the fundamental frequencies of 10 to 15 GHz to produce RF output frequencies of 20 to 30 GHz. Similarly, model MG3694B uses a SDM to double the fundamental frequencies of 10 to 20 GHz to produce RF output frequencies of 20 to 40 GHz.

The RF signal from the switched filter assembly is input to the SDM at J1. During CW or step frequency operations in the 20 to 40 GHz frequency range, the 10 to 20 GHz RF signal input is routed by PIN switches to the doubler/amplifiers. PIN switch drive current is provided by the A6 ALC PCB and bias voltage is provided for the doubler/amplifiers by the A5 AUX PCB assembly. The RF signal is amplified, then doubled in frequency. From the doubler, the 20 to 40 GHz RF signal is routed by PIN switches to the bandpass filters. The A11 SDM has three bandpass filter paths that provide good harmonic performance. The filter frequency ranges are 20 to 25 GHz, 25 to 32 GHz, and 32 to 40 GHz.

After routing through the appropriate bandpass filter, the 20 to 40 GHz RF signal is multiplexed by the PIN switches to the SDM output at connector J2. RF signals input to the SDM of ≤ 20 GHz are multiplexed through by the PIN switches of the SDM to the output connector J2. From J2, the RF signal goes to the directional coupler. Option 15 adds an amplifier between the SDM J2 output and the directional coupler.

For models with Option 22, two diplexers are added that switch the 0.1 Hz to 10 MHz DDS signal, 10 MHz to 2 GHz signal, and 2 GHz to 40 GHz signal into the directional coupler when those respective bands are active.

Source Quadrupler Module

The source quadrupler module, found in > 40 GHz models (see [Figure 2-8](#) through [Figure 2-15](#)), is used to quadruple the fundamental frequencies of 10 to 16.8 or 17.5 GHz to produce RF output frequencies of 40 to 65 or 67 GHz. The RF signal inputs for the SQM come from the switched filter assembly. The modulator control signal for the SQM is received from the A6 ALC PCB where it is developed from the ALC control signal. The A6 PCB also supplies the amplifier bias voltage(s) for the SQM.

Model MG3695B SQM Operation

During CW and swept frequency operations in the 40 to 50 GHz frequency range, the 10 to 12.5 GHz RF signal input is quadrupled and amplified, then goes to the modulator. The modulator provides for power level control. From the modulator, the 40 to 50 GHz RF signals goes via a band-pass filter to output connector J3 of the forward coupler. Note that on the 40 to 50 GHz SQM, the forward coupler is an integral part of the SQM. The 0.01 to 40 GHz RF output signals from the SDM (0.1 Hz to 40 GHz RF output signals from the diplexers for MG3695B with Option 22) are routed to input connector J2 of the SQM forward coupler. The 0.01 to 50 GHz (0.1 Hz to 50 GHz for MG3695B with Option 22) RF output signals go from J3 of the SQM forward coupler to the directional coupler.

Model MG3696B SQM Operation

During CW or swept frequency operations in the 40 to 65 or 67 GHz frequency range, the 10 to 16.8 or 17.5 GHz RF signal input is quadrupled and amplified, then goes to the modulator. The modulator provides for power level control of the RF output signals. From the modulator, the 40 to 65 or 67 GHz RF signals go via a band-pass filter to the output connector of the SQM. From the SQM, the 40 to 65 or 67 GHz RF output signals go through a 37 GHz high pass filter, and then to the input connector J1 of the forward coupler. From the SDM, the 0.01 to 40 GHz RF output signals (0.1 Hz to 40 GHz RF output signals from the diplexers for MG3696B with Option 22) are routed to input connector J2 of the forward coupler. The 0.01 to 65 or 67 GHz (0.1 Hz to 65 or 67 GHz for MG3696B with Option 22) RF output signals go from the output connector J3 of the forward coupler to the directional coupler.

Step Attenuators

The optional step attenuators available for use with the MG369xB models are as follows:

- Mechanical Step Attenuator, 110 dB for MG3691B and MG3692B (Option 2A)
- Mechanical Step Attenuator, 110 dB for MG3693B or MG3694B (Option 2B)
- Mechanical Step Attenuator, 90 dB for MG3695B and MG3696B (Option 2C)
- Electronic Step Attenuator, 120 dB for MG3691B (Option 2E)

Step attenuators provide attenuation of the RF output in 10 dB steps. Maximum rated RF output power is reduced. The step attenuator drive current for Option 2 is supplied by the A6 PCB.

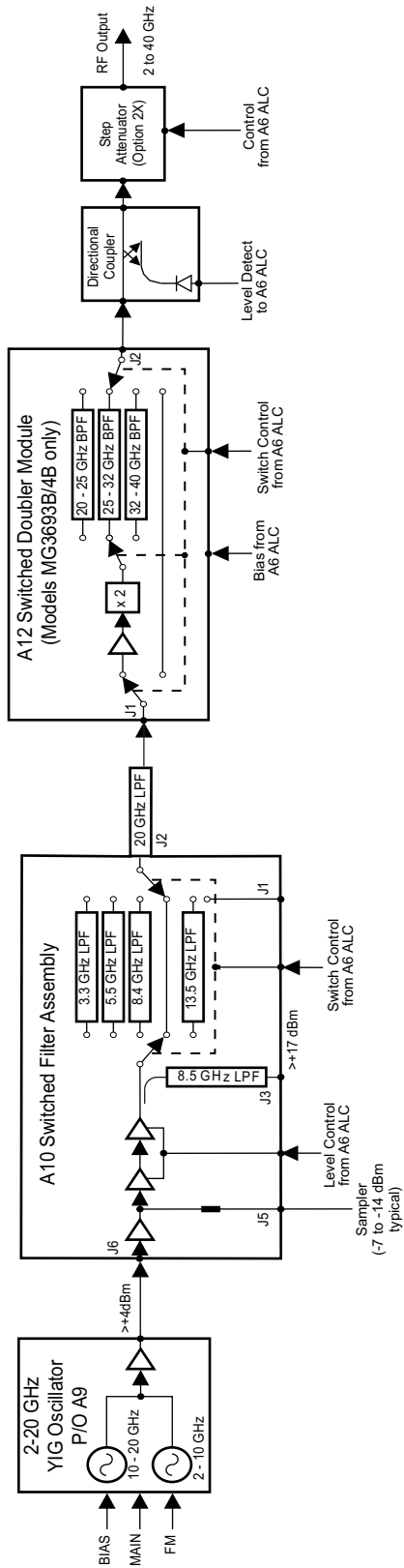

Figure 2-4. Block Diagram of the RF Deck Assembly for Models MG3691B, MG3692B, MG3693B, and MG3694B with No Options

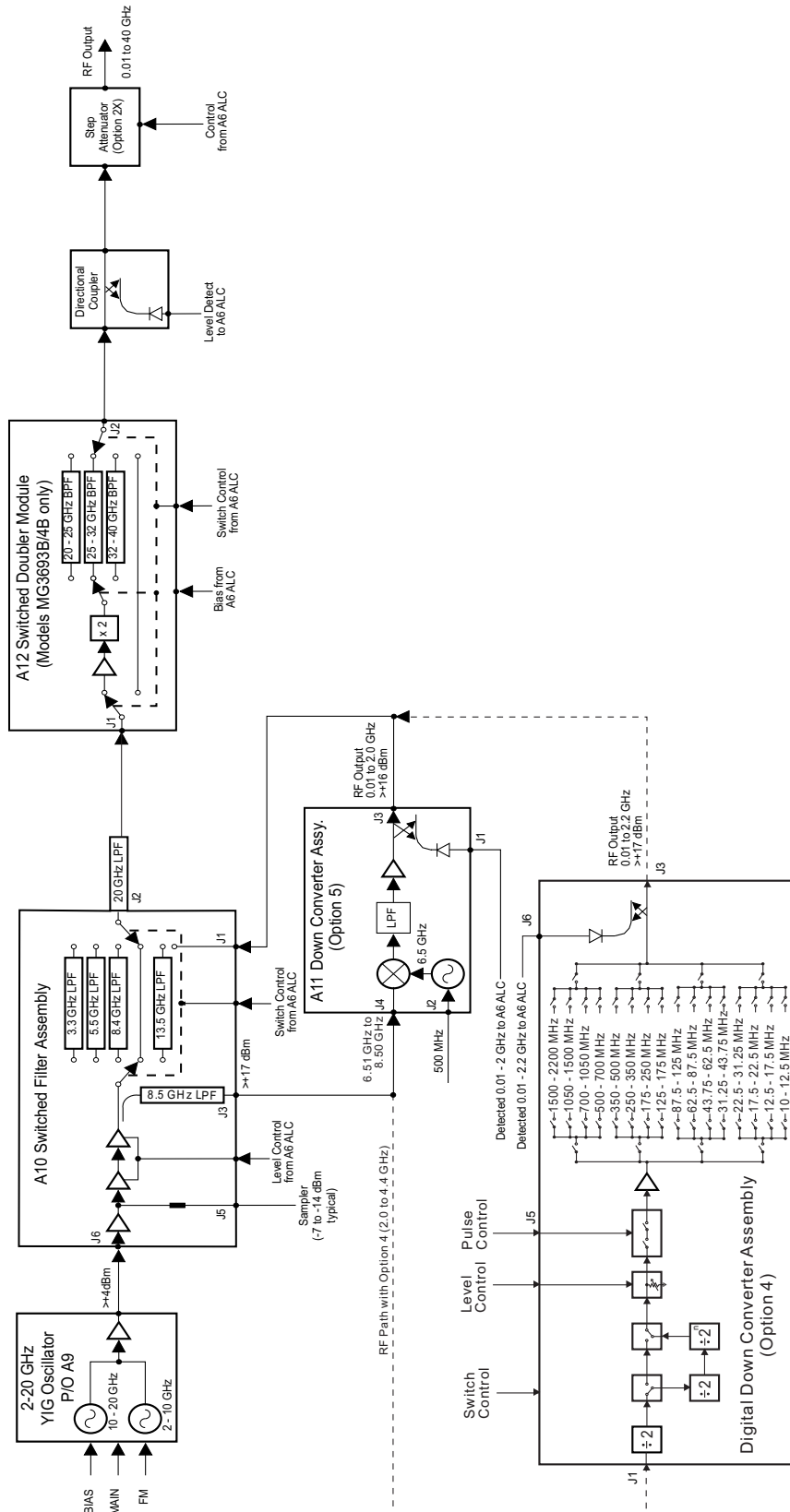

Figure 2-5. Block Diagram of the RF Deck Assembly for Models MG3691B, MG3692B, MG3693B, and MG3694B with Option 4 or 5

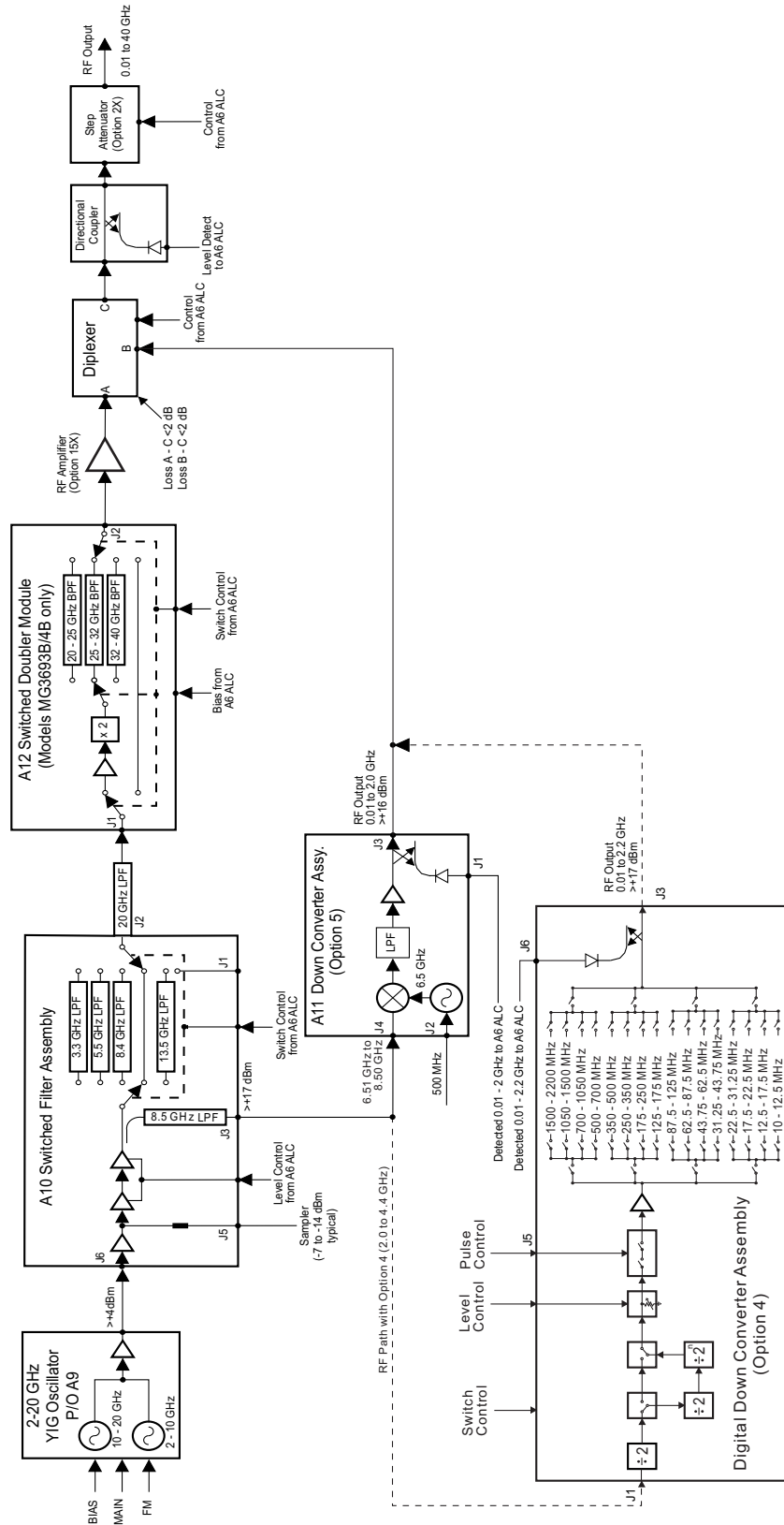

Figure 2-6. Block Diagram of the RF Deck Assembly for Models MG3691B, MG3692B, MG3693B, and MG3694B with Options 4 or 5 and 15

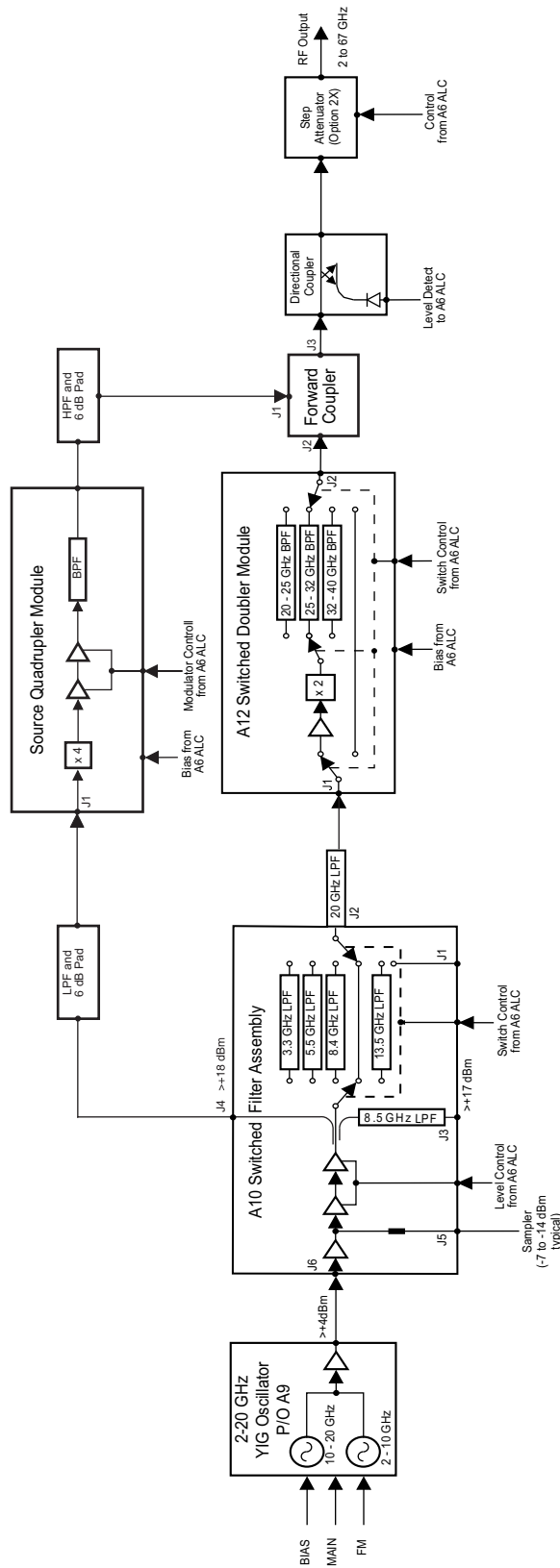

Figure 2-8. Block Diagram of the RF Deck Assembly for Model MG3695B with No Options

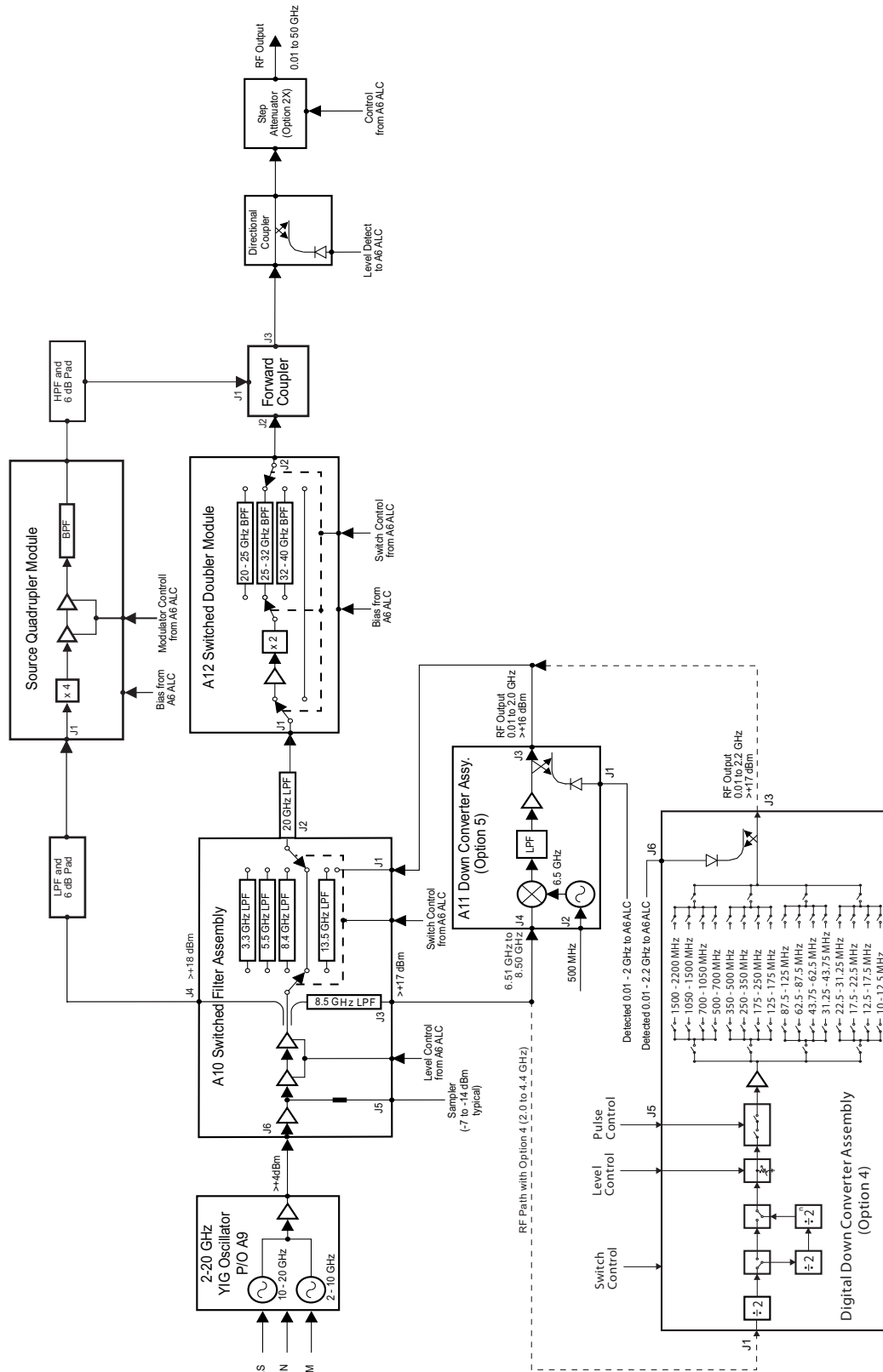

Figure 2-9. Block Diagram of the RF Deck Assembly for Model MG3695B with Option 4 or 5

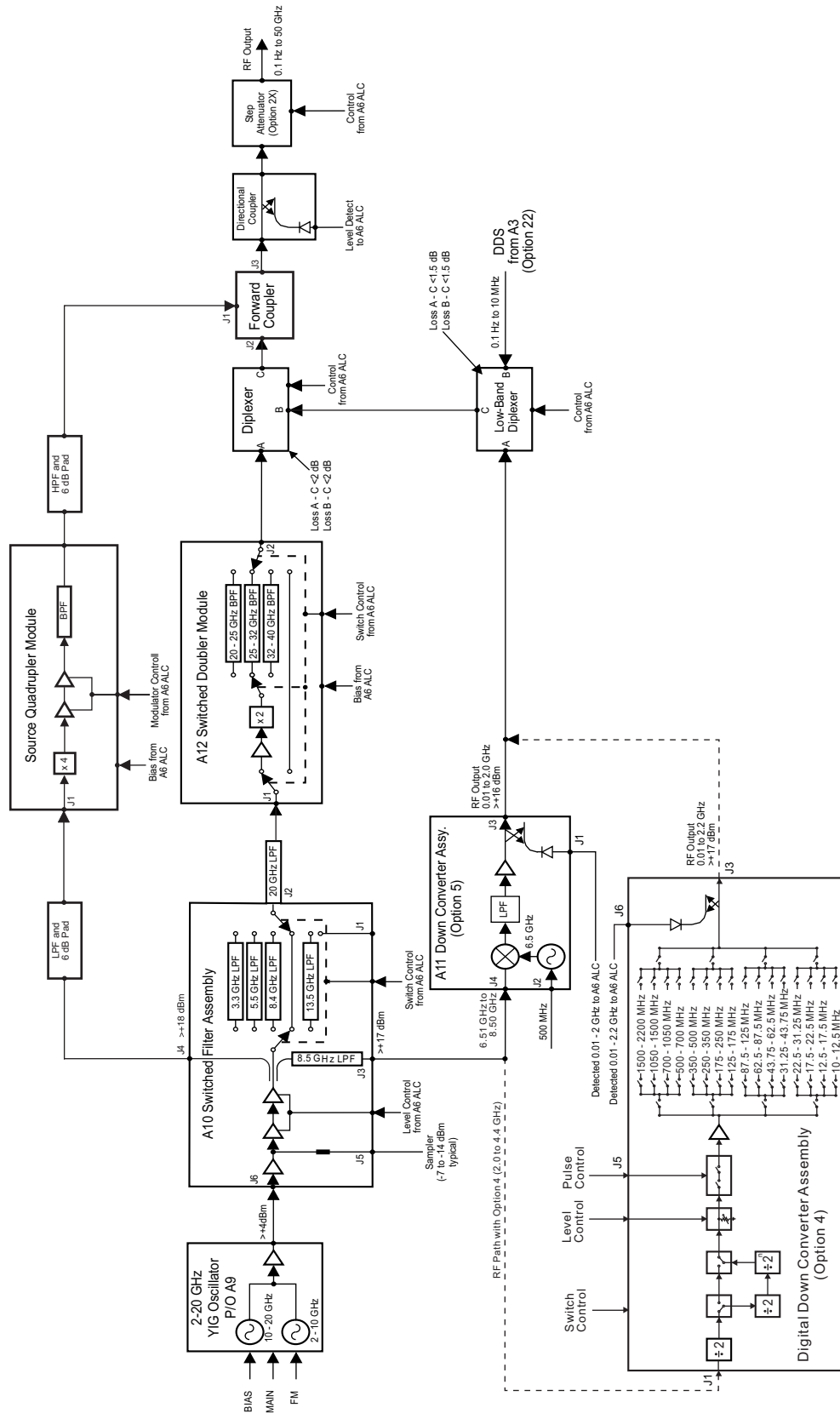

Figure 2-10. Block Diagram of the RF Deck Assembly for Model MG3695B with Options 4 or 5 and 22

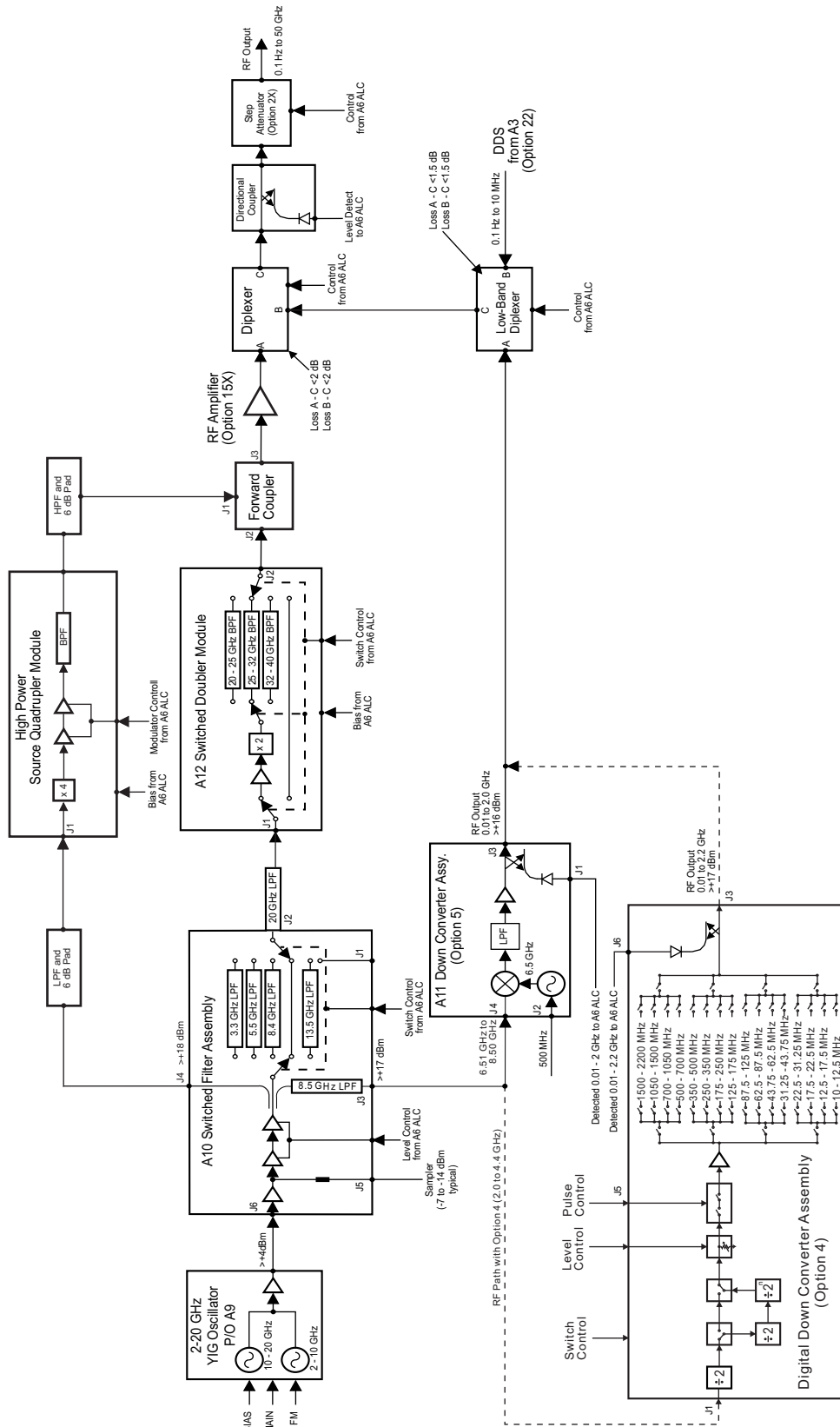

Figure 2-11. Block Diagram of the RF Deck Assembly for Model MG3695B with Options 4 or 5, 15, and 22

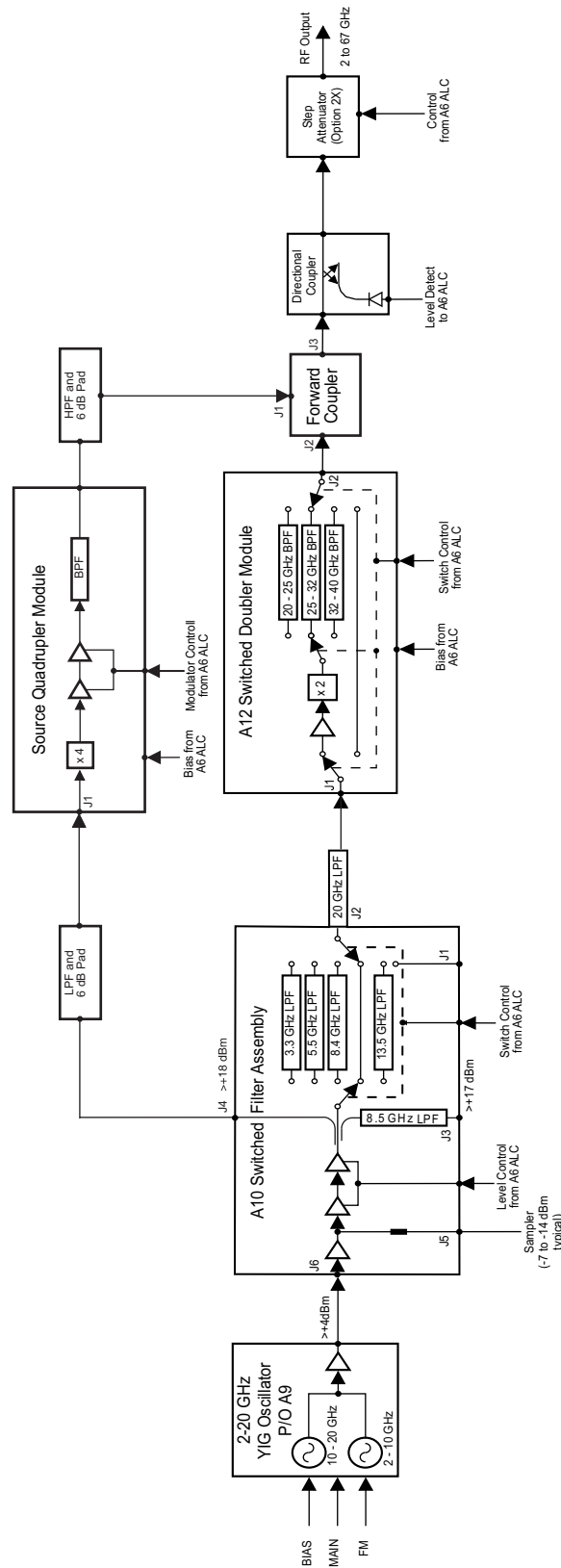

Figure 2-12. Block Diagram of the RF Deck Assembly for Model MG3696B with No Options

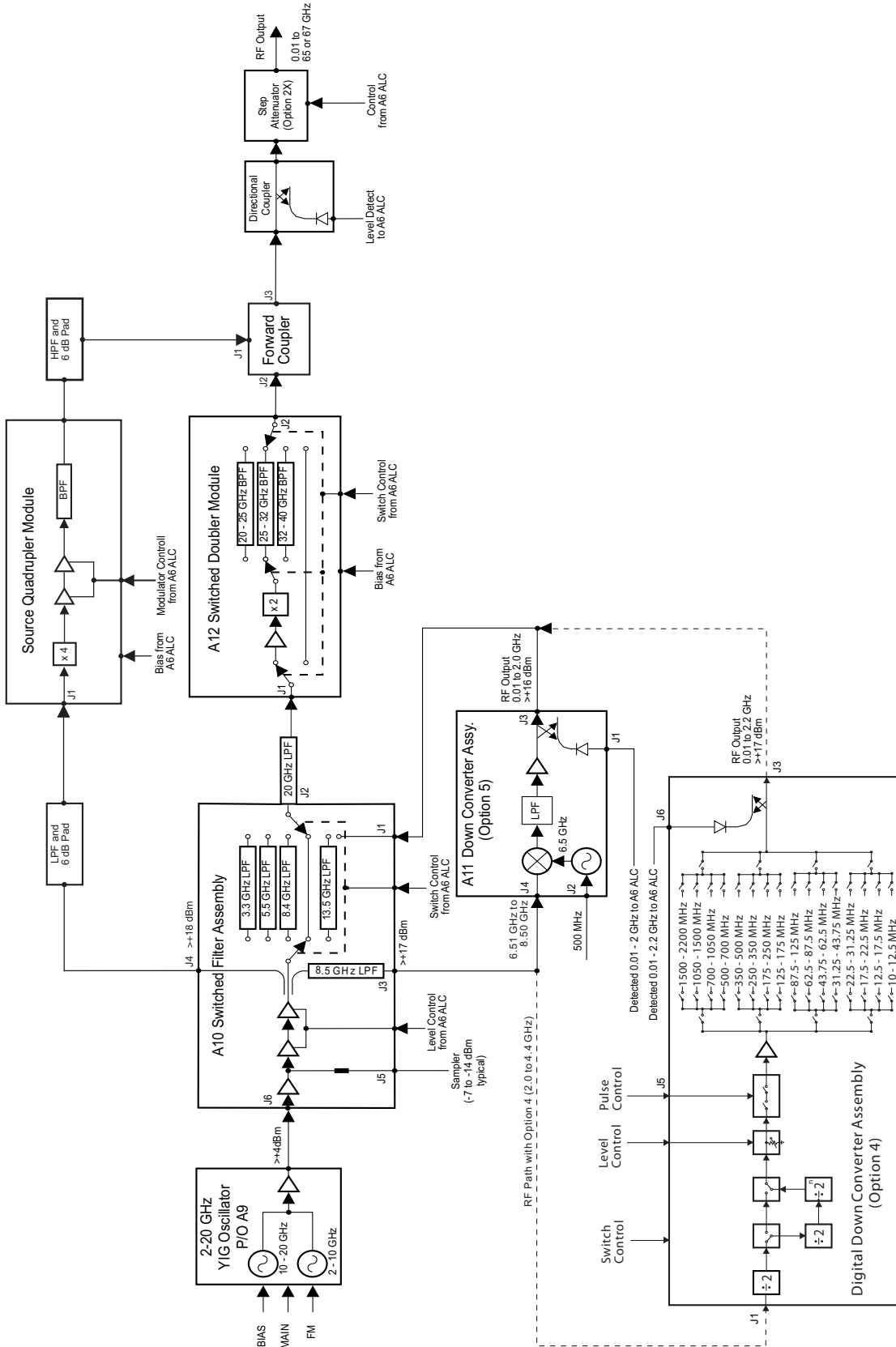

Figure 2-13. Block Diagram of the RF Deck Assembly for Model MG3696B with Option 4 or 5

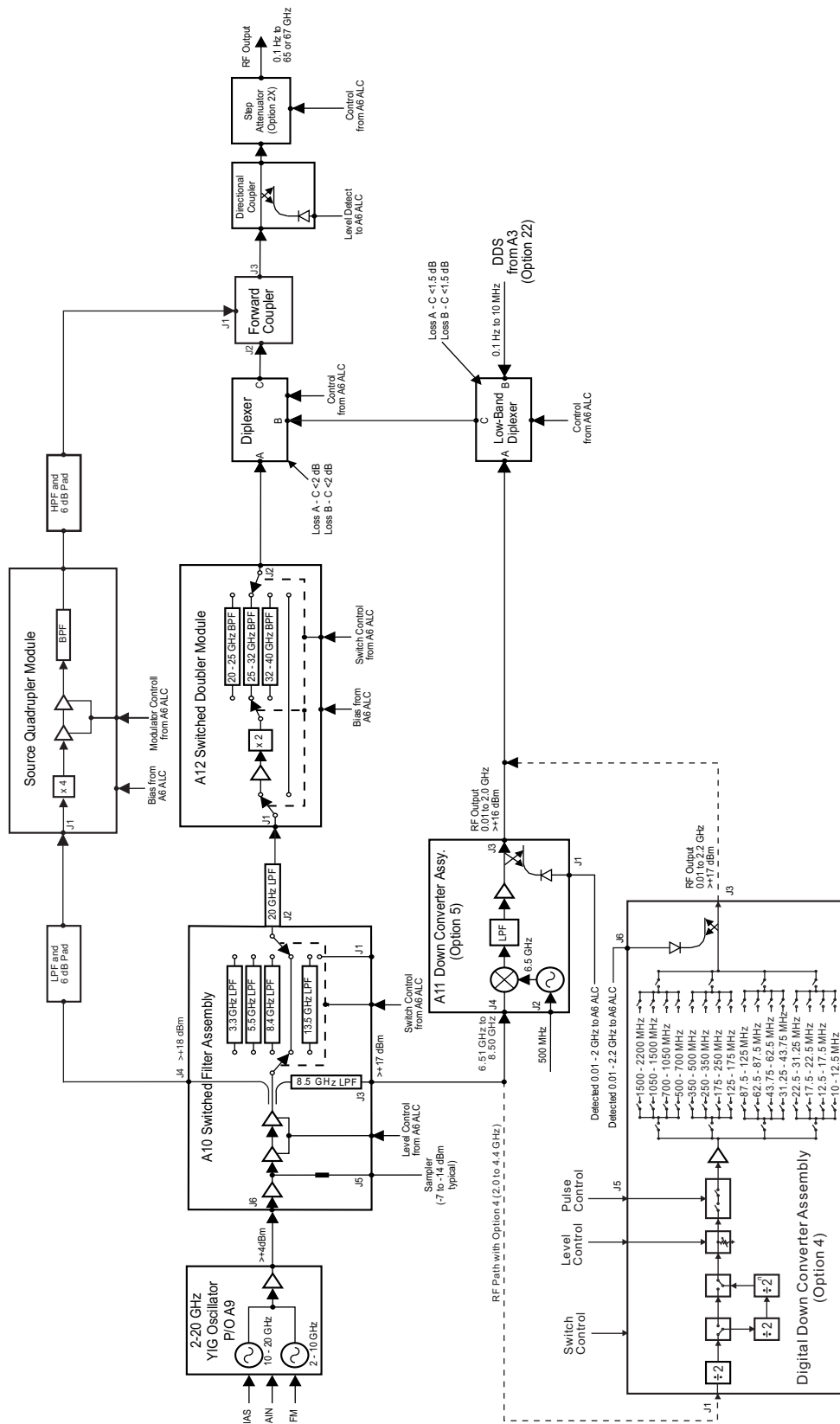

Figure 2-14. Block Diagram of the RF Deck Assembly for Model MG3696B with Option 4 or 5 and 22

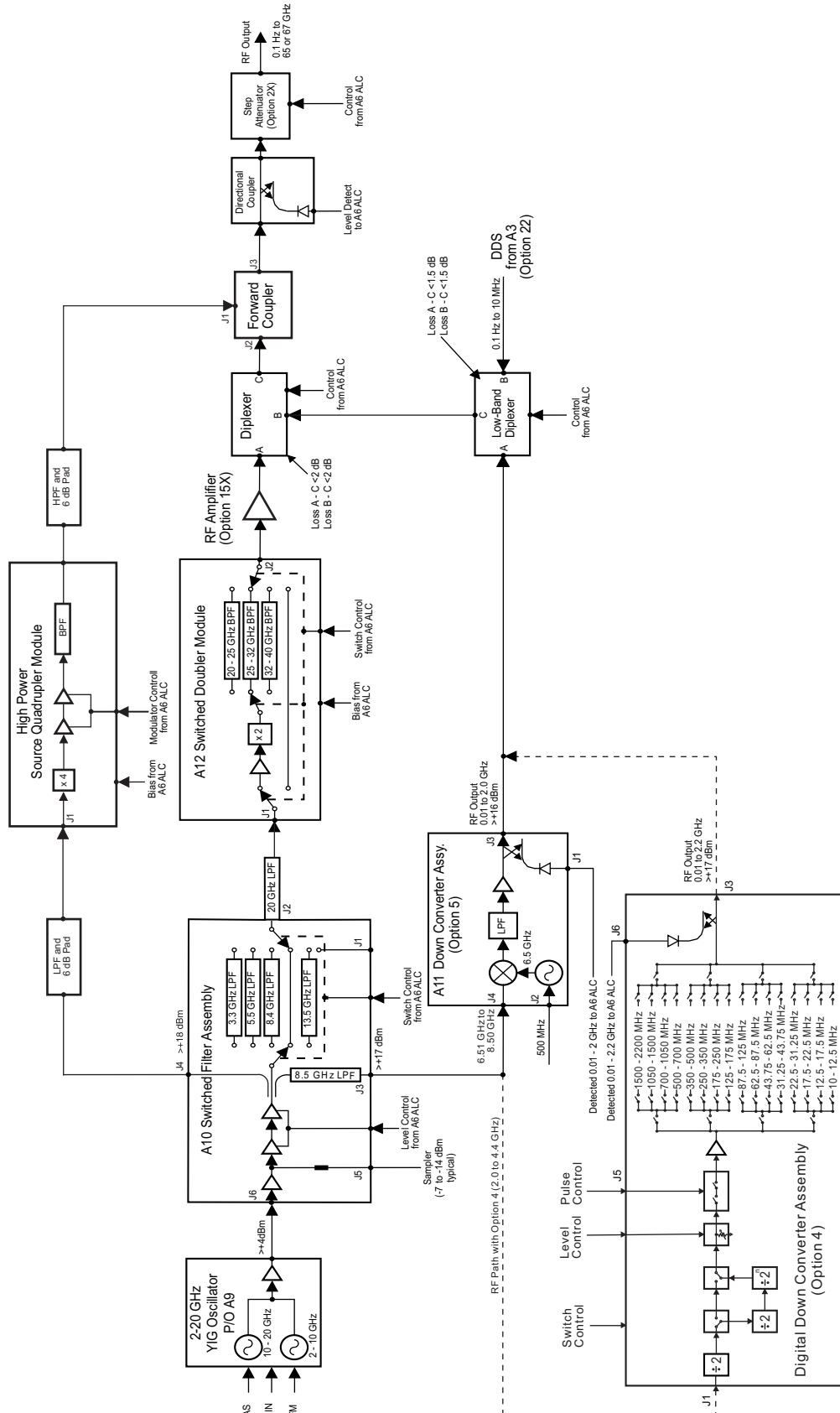

Figure 2-15. Block Diagram of the RF Deck Assembly for Model MG3696B with Option 4 or 5, 15 and 22

Chapter 3 — Performance Verification

3-1 Introduction

This chapter contains tests that can be used to verify the performance of the series MG369xB Synthesized Signal Generators to specifications. These tests support all instrument models having any version of firmware and instrument models with the following options:

- Option 2X, MG369xB (mechanical step attenuator)
- Option 2E, MG3691B (electronic step attenuator)
- Option 3 (ultra low phase noise)
- Option 4 (digital down converter)
- Option 5 (analog down converter)
- Option 6 (analog sweep)
- Option 12 (external frequency and phase modulation)
- Option 13X (external pulse modulation) replaced by Option 26X
- Option 14 (external amplitude modulation)
- Option 15X (high power output)
- Option 16 (high stability time base)
- Option 22 (low frequency audio DDS)
- Option 23 (internal low frequency generator) – replaced by Option 27
- Option 24 (internal pulse generator) – replaced by Option 27
- Option 25X (modulation suite) – replaced by Option 28X
- Option 26X (external pulse modulation)
- Option 27 (internal low frequency and pulse generators)
- Option 28X (analog modulation suite)
- Option 30 (low phase noise)
- Option 37A (Performance Suite) see options 2A, 5, 28A
- Option 38A (Ultra Performance Suite) see options 2, 3, 4, 15A, 22 and 28A

3-2 Test Records

A blank copy of a sample performance verification test record for the MG369xB models is provided in Appendix A. Each test record contains the model-specific variables called for by the test procedures. It also provides a means for maintaining an accurate and complete record of instrument performance. We recommend that you copy these pages and use them to record the results of your initial testing of the instrument. These initial test results can later be used as benchmark values for future tests of the same instrument.

3-3 Connector and Key Notation

The test procedures include many references to equipment interconnections and control settings. For all MG369xB references, specific labels are used to denote the appropriate menu key, data entry key, data entry control, or connector (such as RF Output). Most references to supporting test equipment use general labels for commonly used controls and connections (such as Span or RF Input). In some cases, a specific label is used that is a particular feature of the test equipment listed in [Table 3-1 on page 3-2](#).

3-4 Test Equipment List

Table 3-1 provides a list of the test equipment for the performance verification tests and adjustments. The test equipment setup is critical to making accurate measurements. In some cases, you may substitute test equipment having the same critical specifications as the test equipment indicated in the test equipment list (refer to Section 3-5).

Table 3-1. Test Equipment List (Sheet 1 of 4)

Instrument	Critical Specification	Manufacturer/Model	Usage ⁽¹⁾
Computer running Windows XP	Can not exceed the following configuration: Pentium 4 2.8 GHz 1 GB of memory 2 Serial ports CDROM Mouse Keyboard Monitor Network The computer must be dedicated during calibration and verification activities.	Dell or other common source	C, P
National Instrument PCI GPIB card	PCI GPIB card for computer	National Instrument	C, P
Anritsu RF verification and calibration software		Anritsu 2300-497	C, P
Spectrum Analyzer	Frequency: 100 kHz to 50 GHz Resolution bandwidth: 10 Hz	Agilent 8565EC	C, P
Phase noise measurement system	Frequency range: 5 MHz to 26.5 GHz	Aeroflex/Comstron PN9000 with: PN9060-00 Status Module PN9470-00 Noise Output Module PN9450-00 Lock Control Module PN9342-00 Phase Detector Module PN9530-00 Crystal Oscillator Module or Agilent Phase Noise Station: One K222B INSERTABLE F-F Anritsu One 34NKF50 N Male to K Female Adapter Anritsu One K241C Power Splitter Anritsu One SC3855 3670K50-2 KM-KM flex cable Anritsu One E5052B Signal Source Analyzer Agilent One E5053A Down Converter Agilent Two K120MM-20CM 2 Semi ridged cables K120MM0-20CM (will need to be bent on site to fit) Anritsu One Mouse, Optical, PS2/USB for E5052B One Keyboard USB for E5052B	P
Modulation analyzer	AM and FM measurement capability to > 500 MHz and -20 dBm	HP8901A	P

Table 3-1. Test Equipment List (Sheet 2 of 4)

Instrument	Critical Specification	Manufacturer/Model	Usage ⁽¹⁾
Frequency counter	For use in calibration and performance verification the critical specifications are: Frequency range: 0.01 to 20 GHz Input impedance: 50 Ω Resolution: 1 Hz Other: External time base input For use with only performance verification the critical specifications are: Frequency range: 0.01 to 6 GHz Input impedance: 50 Ω Resolution: 1 Hz Other: External time base input	For calibration and performance verification the recommendation is Anritsu model MF2414B or For performance verification the recommendation is Anritsu model MF2412B	C, P
Power meter	Frequency: 100 kHz to 67 GHz Power range: -70 to +20 dBm	Anritsu model ML2437A/38A	C, P
Power sensor for power meter	Frequency: 0.01 to 40 GHz (K) Power range: -70 to +20 dBm	Anritsu model MA2474D	C, P
Power sensor for power meter	Frequency: 0.01 to 50 GHz (V) Power range: -70 to +20 dBm	Anritsu model MA2475D	C, P
Power sensor for power meter	Frequency: 0.01 to 67 GHz (V) Power range: -30 to +20 dBm	Anritsu model SC7430 or Anritsu model SC7570	C, P
Power sensor for power meter	Frequency: 100 kHz to 18 GHz (N) Power range: -55 +20 dBm	Anritsu model SC7400	C, P
Adapter for power sensor SC7400	N female to K adapter	Anritsu model 34NFK50	C, P
Adapter for power sensor calibration	N(m) to K(f)	Anritsu 34NKF50	C, P
Adapters for power sensor calibration	N(m) to V(f)	Common source or Alternate to achieve N(m) to V(f): Anritsu model 34NK50 + 34VKF50 or Anritsu model 34NKF50 + 34VK50	C, P
Special AUX I/O cable assembly	Provides interface between the MG369xB and the power meter	Anritsu PN: 806-97	P
Digital multimeter	Minimum 1% RMS ACV accuracy at 100 kHz	Fluke 8840A	P
Function generator	Frequency: 0.1 Hz to 15 MHz	Agilent 33120A	C, P
Digital sampling oscilloscope	Frequency: 50 GHz	Agilent 86100A with 83484A 50 GHz module	P
Frequency reference	Frequency: 10 MHz Accuracy: 5×10^{-12} parts/day	Absolute Time Corp., model 300 or Symmetricom (Datum) model 9390-9600	P

Table 3-1. Test Equipment List (Sheet 3 of 4)

Instrument	Critical Specification	Manufacturer/Model	Usage ⁽¹⁾
Measuring receiver ⁽²⁾	Noise floor: < -140 dBm @ 500 MHz	Anritsu model ML2530A	C, P
Local oscillator	Frequency: 0.01 to 40 GHz	Anritsu Model MG3694B with options: 3, 4, 16, and SM6191 (unit must not have options 2B, 15B or 22) Note: If the T2579 mixer box is ordered, then special SM6191 must be added to the LO.	C, P
Mixer	Frequency range: 500 MHz to 40 GHz Conversion loss: 10 dBm (typical)	Anritsu PN: 60-114	P
M to M Adapter	K(m) to K(m)	Anritsu P/N: K220B	P
Mixer box ⁽²⁾ (for low level calibration)	Frequency range: 0.01 GHz to 40 GHz	Anritsu PN: T2579	C, P
Low pass filter (Qty = 2) ⁽²⁾	1.9 GHz LPF	Mini-Circuits BPL-1.9 or Anritsu PN: 1030-104	C, P
AUX I/O interface cable	Provides interface between the instrument under test and the 56100A Scalar Network Analyzer	Anritsu PN: 806-7	C
Attenuator for instrument model numbers MG3691B through MG3694B	Frequency range: DC to 40 GHz Attenuation: 3, 6, 10, and 20 dB (sizes and counts are determined depending on options and maximum output power of instrument)	Anritsu part number SC7879 K set of attenuators (41KC-3, 41KC-6, 41KC-10, 41KC-20) calibrated from 100 K to 40 GHz or Anritsu, model 41KC-3, 41KC-6, 41KC-10 or 41KC-20 calibrated at the following data points: 100 kHz, 1 MHz, 10 MHz, 100 MHz, 500 MHz to 67 GHz in 500 MHz steps	C, P
Attenuator for instrument model numbers MG3695B through MG3696B	Frequency Range: DC to 65 GHz Attenuation: 3, 6, 10, and 20 dB (sizes and counts are determined depending on options and maximum output power of instrument)	Anritsu part number SC7880 V set of attenuators (41V-3, 41V-6, 41V-10, 41V-20) calibrated from 100 K to 67 GHz. or Anritsu, model 41V-3, 41V-6, 41V-10 and 41V-20 calibrated at the following data points: 100 kHz, 1 MHz, 10 MHz, 100 MHz, 500 MHz to 67 GHz in 500 MHz steps	C, P
BNC Tee	Connectors: 50 Ω BNC	Any common source	C, P
Generic 50 Ω BNC RF cables and connectors		Any common source	C, P
Generic GPIB cables		Any common source	C, P
BNC to SMA adapter	BNC to SMA Adapter	Any common source	P
K(m) to K(m) flex cables or semi-rigid cables	K(m) to K(m) flex cables or Semi-rigid cables	Anritsu SC3855 3670K50-2 K(m) to K(m) flex cable or Anritsu K120mm-60CM custom semi-rigid cable	C, P

Table 3-1. Test Equipment List (Sheet 4 of 4)

Instrument	Critical Specification	Manufacturer/Model	Usage ⁽¹⁾
V(m) to V(m) flex cables or semi-rigid cables	V(m) to V(m) flex cables or Semi-rigid cables	Anritsu APN 3670V50-2 V(m) to V(m) flex cable or Anritsu V120mm-60CM Custom Semi-rigid cable	C, P
Special Serial I/O Cable Assembly	Provides interface between the MG3690B and the PC	Anritsu P/N: T1678	C, P

1. P = Performance Verification Tests, C = Calibration, T = Troubleshooting
2. Only needed if option 2X is installed.

3-5 Measurement Uncertainty

In Appendix A, all test records are provided with a measurement uncertainty, which consists of the type-B¹ components. The error contributions are primarily from the measurement method, test equipment, standards, and other correction factors (e.g., calibration factors and mismatch error) per the prescribed test procedure. The statement(s) of compliance with specification² is based on a 95% coverage probability for the expanded uncertainty of the measurement results on which the decision of compliance is based. Other values for the coverage probability for the expanded uncertainty may be reported, where practicable, for some of the measured values it is not possible to make a statement of compliance with specification².

3-6 Internal Time Base Aging Rate Test (Optional)

The following test can be used to verify that the MG369xB 10 MHz time base is within its aging specification. The instrument derives its frequency accuracy from an internal 10 MHz crystal oscillator standard. (With Option 16 installed, frequency accuracy is derived from an internal high-stability 10 MHz crystal oscillator.) An inherent characteristic of crystal oscillators is the effect of crystal *aging* within the first few days to weeks of operation. Typically, the frequency of the crystal oscillator increases slightly at first, then settles to a relatively constant value for the rest of its life.

Note

Do not confuse crystal aging with other short term frequency instabilities, for example, noise and temperature. The internal time base of the instrument may not achieve its specified aging rate before the specified warm-up time of 7 to 30 days has elapsed; therefore, this performance test is optional.

For the greatest absolute frequency accuracy, allow the MG369xB to warm up until its RF output frequency has stabilized (usually 7 to 30 days). Once stabilized, the change in reference oscillator frequency should remain within the aging rate if (1) the time base oven is not allowed to cool, (2) the instrument orientation with respect to the earth's magnetic field is maintained, (3) the instrument does not sustain any mechanical shock, and (4) ambient temperature is held constant. This test should be performed upon receipt of the instrument and again after several days or weeks to fully qualify the aging rate.

Note

Before performing this procedure ensure that all test equipment is calibrated. Refer to the manufacturer's test equipment manual.

1. BIPM JCGM 100:2008 Evaluation of measurement data- Guide to the expression of uncertainty in measurement.
2. ILAC-G8:03/2009: Guidelines on the Reporting of Compliance with Specification.

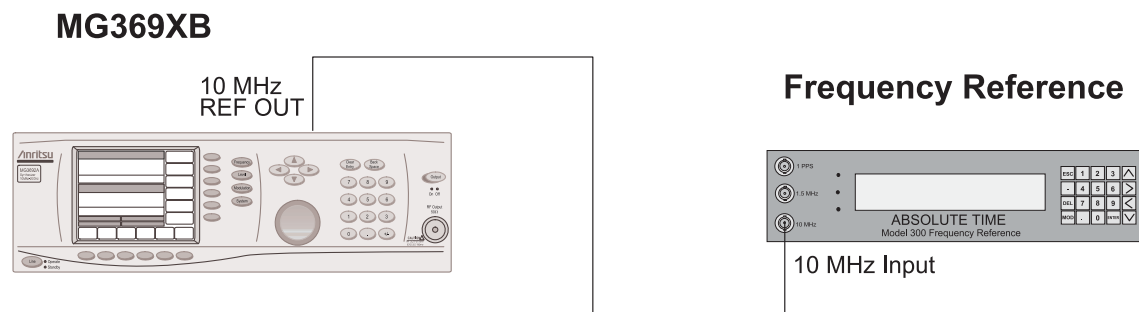

Figure 3-1. Equipment Setup for Internal Time Base Aging Rate Tests

Note

There are two procedures for Internal Time Base Aging Rate based on the frequency reference used. The first procedure is for Absolute Time Corp model 300 use, the second is for Symmetricon (Datum) model 9390-9600 use.

Internal Time Base Aging Rate Test with Absolute Time Model 300

Test Setup

Connect the MG369xB rear panel 10 MHz REF OUT to the frequency reference front panel input connector labeled 10 MHz when directed to do so during the test procedure.

Test Procedure

The frequency error is measured at the start and finish of the test time period of 24 hours. The aging rate is the difference between the two error readings.

1. Set up the model 300 frequency reference as follows:
 - a. Press the ESC key until the MAIN MENU is displayed.
 - b. At the MAIN MENU display, press 1 to select the CONFIGURATION MENU.
 - c. At the CONFIGURATION MENU display, press 8 to select MEAS.
 - d. Press the MOD key and use the Up/Down arrow keys to get to the menu display: MEASUREMENT = FREQ.
 - e. Press the ENTER key.
 - f. Press the ESC key until the MAIN MENU is displayed.
 - g. At the MAIN MENU display, press 3 to select the REVIEW MENU.
 - h. At the REVIEW MENU display, press 8 to select TFM.
2. Connect the MG369xB rear panel 10 MHz REF OUT signal to the frequency reference front panel 10 MHz input.
3. Wait approximately 90 minutes (default setting) until the FMFOM on the frequency reference display decreases from 9 to 1. (The default setting is recommended to achieve optimum measurements.)
4. The frequency error in the signal under test is displayed in ps/s (picoseconds/second). For example, an error of -644681 ps/s is -644681×10^{-12} or -6.44681×10^{-7} away from the 10 MHz internal reference on the frequency reference.
5. The frequency error display is continuously updated as a running 5,000-second average. The averaging smooths out the short-term instability of the oscillator.
6. Record the frequency error value displayed on the frequency reference in the test record.

7. Wait for 24 hours, then record the frequency error value in the test record.
8. The aging rate is the difference between the two frequency error values.
9. Record the computed result in the test record. To meet the specification, the computed aging rate must be $< 2 \times 10^{-9}$ per day ($< 5 \times 10^{-10}$ per day with Option 16).

Internal Time Base Aging Rate Test with Symmetricom (Datum) Model 9390-9600

Test Setup

Connect the MG369xB rear panel 10 MHz REF OUT to the Symmetricom (Datum) model 9390-9600 frequency standard rear panel BNC connector labeled J10. The frequency standard must be actively tracking at least three satellites, and the oscillator should be stabilized/locked (i.e., the front panel TRACKING and LOCKED LEDS should be illuminated).

Test Procedure

On the frequency standard:

1. Cycle the menu screen to the sixth screen (External Frequency Measurement) as shown below.

Row 1	EXT Freq: +0000E-14 / +0000E+00 SEC *
Row 2	<1>Enter Freq <2>ENABLE <3>DISABLE

2. Push keyboard switch “1” followed by the number 10000000. This will input the test frequency of 10 MHz.
3. Push keyboard switch “2” to ENABLE the external frequency measurement option. (pushing switch “3” will DISABLE it)
4. Confirm that the external frequency measurement option is enabled and the unit is locked by observing an “*” in row 1, column 35 of the display. If “NOTLK” appears then the frequency standard is not locked and testing must be halted. If no “*” appears then the unit is not connected properly.
5. Confirm that the measurement count has started to increment. This will be displayed in row 1, columns 20 through 29 of the display. Allow approximately 5 minutes for everything to stabilize.
6. Record the date/time of the test starting and the frequency offset displayed in row 1 column 9 through 17 on the test record as frequency error value.
7. After 24 hours push keyboard switch 3 to disable the measurement. Note that the “*” will disappear.
8. Record the date and time of the testing completion, and also the frequency offset displayed in row 1 column 9 through 17 on the test record as frequency error value (after 24 hours).
9. The aging rate is the difference between frequency error value and frequency value (after 24 hours). Record this value into the test record and compare it to the upper limit.

3-7 Spurious Signals Test

The following tests can be used to verify that the signal generator meets its spurious emissions specifications for RF output signals from 0.01 to 50 GHz.

The MG369xB's CW RF output signal is fed directly into a Spectrum Analyzer. The CW frequency and power level is referenced and a peak search function on the Spectrum Analyzer is utilized to find any spurious signals above the specified limit.

Note Before performing this procedure ensure that all test equipment is calibrated. Refer to the manufacturer's test equipment manual.

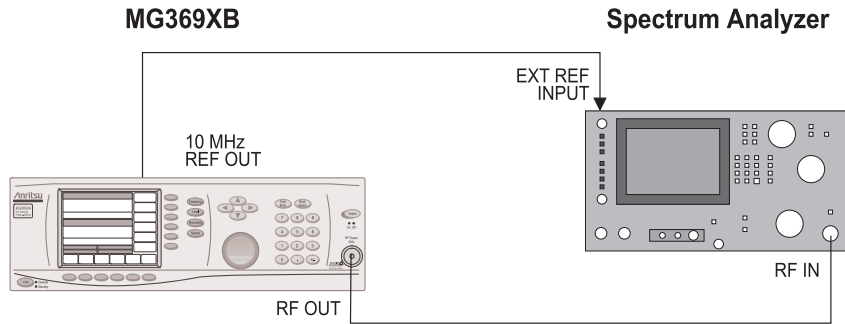

Figure 3-2. Equipment Setup for Spurious Signals Test

Harmonic Test Initial Setup Procedure

Connect the equipment shown in [Figure 3-2](#), as follows:

1. Connect the MG369xB rear panel 10 MHz REF OUT to the Spectrum Analyzer's external reference input.
2. Connect the MG369xB RF Output to the Spectrum Analyzer's RF input.

Note Power line and fan rotation spurious emissions are tested as part of the single sideband phase noise test in [Section 3-8](#).

3. Set up the Spectrum Analyzer as follows:

- a. Press the **PRESET** key.
- b. Press **AUX CTRL**.
- c. Press Rear Panel.
- d. Press 10MHz and set to "EXT".

Harmonic Test Procedure

1. Determine the first test frequency to test based on the test record, options and model number.
2. Set up the MG369xB as follows:
 - a. Reset the instrument by pressing **SYSTEM**, then **Reset**. After reset, the CW menu is displayed.
 - b. Press **Edit F1** to open the current frequency parameter for editing and set F1 to the first appropriate test frequency (based on model and options) in the test record.
 - c. Press **Edit L1** to open the current power level parameter for editing.

- d. Set L1 to +10 dBm or to the maximum specified power level, whichever is less. Refer to Appendix B, Technical Data Sheet, for the maximum specified power levels. For the electronic version of this manual, refer to the MG369xB Technical Data Sheet, PN: 11410-00344 on the Anritsu Internet site.
3. Set up the Spectrum Analyzer as follows:
 - a. Press the **AMPLITUDE** key. Press REF LVL and enter the current power level setting (L1) of the MG369xB.
 - b. Press the **FREQUENCY** key and enter the current frequency setting (F1) of the MG369xB.
 - c. Press the **BW** key and press MAN. Set to the first appropriate test frequency's RBW/VBW value (based on model and options) in the test record.
 - d. Press the **SPAN** key and set to the first appropriate test frequency's SPAN value (based on model and options) in the test record.
 4. Press the **PEAK SEARCH** key, then select MARKER DELTA.
 5. Press the **FREQUENCY** key on the Spectrum Analyzer and enter next harmonic frequency listed in the test records.
 6. Press the **PEAK SEARCH** key.
 7. Record the reading from the Spectrum Analyzer into the test record.
 8. Repeat steps 5 through 7 for each of the harmonic frequency listed in the test record.
 9. Press Edit F1 on the MG369xB to open the current frequency parameter for editing and set F1 to the next appropriate test frequency (based on model and options) in the test record. Then on SPA, press the **FREQUENCY** key and enter the current frequency setting (F1) of the MG369xB.
 10. Determine if the power level for the MG369xB and Spectrum Analyzer changes based on the new frequency or options. If so, adjust the MG369xB L1 and Spectrum Analyzer amplitude as needed.
 11. Press the **SPAN** key and enter the value listed in the test record for the appropriate test frequency.
 12. Press the **BW** key and enter the value listed in the test record for the appropriate test frequency.
 13. Repeat steps 4 through 12 for each of the test frequencies listed in the test record.

Non-Harmonic Initial Setup Procedure

Connect the equipment, shown in [Figure 3-2](#).

1. Connect the MG369xB rear panel 10 MHz REF OUT to the Spectrum Analyzer's external reference input.
2. Connect the MG369xB RF Output to the Spectrum Analyzer's RF input.

Note Power line and fan rotation spurious emissions are tested as part of the single sideband phase noise test in [Section 3-8](#).

3. Set up the Spectrum Analyzer as follows:
 - a. Press the **PRESET** key.
 - b. Press **AUX CTRL**.
 - c. Press Rear Panel.
 - d. Press 10MHz and set to "EXT".
4. Set up the MG369xB as follows:
 - Reset the instrument by pressing **SYSTEM**, then **Reset**. After reset, the CW menu is displayed.

Non-Harmonic Test Procedure

Part 1

1. Set up the MG369xB as follows:
 - a. Press **Edit F1** to open the current frequency parameter for editing.
 - b. Set F1 to the appropriate test frequency (based on model and options) in the test record, part 1.
 - c. Press **Edit L1** to open the current power level parameter for editing.
 - d. Set L1 to +10 dBm or to the maximum specified power level, whichever is less. (Refer to Appendix B, Technical Data Sheet, for the maximum specified power levels.)
2. Set up the Spectrum Analyzer as follows:
 - a. Press the **AMPLITUDE** key.
 - b. Press **REF LVL** and enter the current power level setting (L1) of the MG369xB.
 - c. Press the **FREQUENCY** key.
 - d. Press **Start Freq.**
 - e. Enter the current Spectrum Analyzer start frequency from the test record.
 - f. Press **Stop Freq.**
 - g. Enter the current Spectrum Analyzer stop frequency from the test record.
 - h. Press the **BW** key.
 - i. Press **Res BW to MAN.**
 - j. Enter the current Spectrum Analyzer RBW value from the test record.
3. Press the **PEAK SEARCH** key, and then select **MARKER DELTA**.
4. Set up the Spectrum Analyzer as follows:
 - a. Press the **FREQUENCY** key.
 - b. Press **Start Freq.**
 - c. Enter the next Spectrum Analyzer start frequency from the test record.
 - d. Press **Stop Freq.**
 - e. Enter the next Spectrum Analyzer stop frequency from the test record.
 - f. Press the **BW** key.
 - g. If needed, press **Res BW to MAN.**
 - h. Enter the next Spectrum Analyzer RBW value from the test record.
5. Press **PEAK SEARCH** then **Next Peak**.
6. Record the reading from the Spectrum Analyzer Delta MKH reading into the test record.
7. Repeat steps 4 through 6 for same specified MG369xB frequency listed in the test record, part 1.
8. Repeat steps 1 through 7 for same each MG369xB frequency groups listed in the test record, part 1.

Part 2

1. Set up the MG369xB as follows:
 - a. Press **Edit F1** to open the current frequency parameter for editing.
 - b. Set **F1** to the appropriate test frequency (based on model and options) in the test record, part 2.
 - c. Press **Edit L1** to open the current power level parameter for editing.
 - d. Set **L1** to +10 dBm or to the maximum specified power level, whichever is less. (Refer to Appendix B, Technical Data Sheet, for the maximum specified power levels.)
2. Set up the Spectrum Analyzer as follows:
 - a. Press the **AMPLITUDE** key.
 - b. Press **REF LVL** and enter the current power level setting (**L1**) of the MG369xB.
 - c. Press the **FREQUENCY** key.
 - d. Press **Center Freq.**
 - e. Enter the current Spectrum Analyzer center frequency from the test record.
 - f. Press **SPAN**.
 - g. Enter the current Spectrum Analyzer span frequency from the test record.
 - h. Press the **BW** key.
 - i. Press **Res BW** to **MAN**.
 - j. Enter the current Spectrum Analyzer RBW value from the test record.
3. Press the **PEAK SEARCH** key, and then select **MARKER DELTA**, which sets the reference for the following measurements.
4. Set up the Spectrum Analyzer as follows:
 - a. Press the **FREQUENCY** key.
 - b. Press **Center Freq.**
 - c. Enter the next Spectrum Analyzer center frequency from the test record.
 - d. Press the **BW** key.
 - e. If needed, press **Res BW** to **MAN**.
 - f. Enter the next Spectrum Analyzer RBW value from the test record.
5. Press **PEAK SEARCH** then **Next Peak**.
6. Record the reading from the Spectrum Analyzer Delta MKH reading into the test record.
7. Repeat steps 4 through 6 for same specified MG369xB frequency listed in the test record, part 2.
8. Repeat steps 1 through 7 for same each MG369xB frequency groups listed in the test record, part 2.

3-8 Single Sideband Phase Noise Test

There are 2 different procedures depending on what test equipment is available.

- “Agilent E5052B Signal Source Analyzer and E5053A Down Converter” on page 3-12
- “AeroFlex PN9000 Phase Noise System” on page 3-17

Agilent E5052B Signal Source Analyzer and E5053A Down Converter

The section below contains the information to perform the verification using the Agilent E5052B Signal Source Analyzer and E5053A down converter.:

Table 3-2. Recommend Equipment List

Recommend Part Number	Quantity	Description	Vendor
K222B	1	Insertable F-F	Anritsu
34NKF50	1	N Male to K Female Adapter	Anritsu
K241C	1	Power Splitter	Anritsu
SC3855	1	3670K50-2 KM-KM flex cable	Anritsu
E5052B	1	Signal Source Analyzer	Agilent
E5053A	1	Down Converter	Agilent
K120MM-20CM	2	Semi ridged cables K120MM0-20CM (this will need to be bent on site to fit)	Anritsu
	1	Mouse, Optical, PS2/USB for E5052B	
	1	Keyboard USB for E5052B	

Test Setup

Note

The MG369xB, E5052B and the E5053A Down converter must be powered on for a minimum of 30 minutes before taking performing these measurements. The E5052B and E5053A must be installed and set up in accordance with the instructions supplied with the instruments before continuing with this procedure.

1. Set up the MG369xB as follows:
 - a. Reset the instrument by pressing **System**, then **Reset**. Upon reset, the CW menu is displayed.
 - b. Press **Frequency** to open the current frequency parameter for editing.
 - c. Set F1 to the CW frequency indicated in the test record.
 - d. Press **Edit L1** to open the current power level parameter for editing. Set L1 to +10 dBm or the maximum leveled power of the instrument which ever is lower.

Note

If you are not using the splitter, reduce L1 power level to +8 dBm.

- e. Connect the MG369xB as shown in [Figure 3-3](#).
 - i. Connect the output of the MG369xB to the input of the splitter.
 - ii. Connect one of the outputs of the splitter to the RF input of the E5052B
 - iii. Connect one of the outputs of the splitter to the RF input of the down converter.

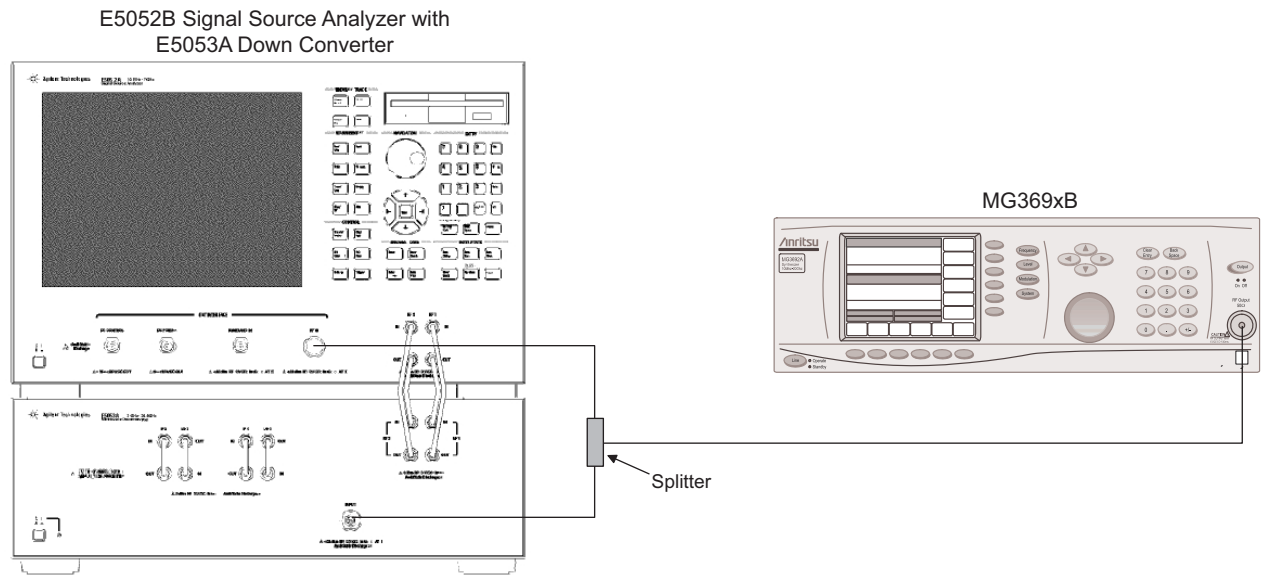

Figure 3-3. Equipment Setup for Single Sideband Phase Noise Test with E5052B and E5053A

2. E5052B and E5053A setup:

- a. Press the green **Preset** button.
 - Touch **Factory**.
- b. Press **Measure/View**.
 - Touch **Phase Noise**.
- c. Press **Window Max**.
- d. Press **Start/Center**.
 - Touch **10 Hz**.
- e. Press **Stop/Span**.
 - Touch **1 MHz**.
- f. Press **Marker**.
 - i. Touch **Marker 1**, enter **10 hit X1** to obtain 10 Hz (used with option 3 or 30).
 - ii. Touch **Marker 2**, enter **100 hit X1** to obtain 100 Hz.
 - iii. Touch **Marker 3**, enter **1 hit k/M** to obtain 1 kHz.
 - iv. Touch **Marker 4**, enter **10 hit k/M** to obtain 10 kHz.
 - v. Touch **Marker 5**, enter **100 hit k/m** to obtain 100 kHz.
 - vi. Touch **Marker 6**, enter **1 hit M/u** to obtain 1 MHz (used with option 3 or 30).
- g. Press **Avg/BW**.
 - Touch **correlation** and set to **10**.

Test Procedure

1. Refer to the test records for Phase Noise. Use the correct table based on the options installed in the MG369xB.
2. Determine the test frequency.
3. Set the MG369xB F1 to the frequency called out in the test records.
4. Press **Input** on the E5052B.

Note	Frequencies from 10 MHz to 5 GHz are measuring using the E5052B. Frequencies from 5 to 25 GHz are measured using the 5053A down converter and E5052B.
-------------	---

- a. If the test frequencies are from 10 MHz to < 5 GHz
 - i. Touch Downconverter.
 - ii. Touch RF input.
 - iii. Touch E5053A. This selects the direct measurement into the E5053A.
 - iv. Touch Downconverter and confirm it is off.
 - b. If the test frequencies are from ≥ 5 GHz to 25 GHz
 - i. Touch Downconverter.
 - ii. Touch Downconverter, make sure it ON.
 - iii. Touch RF input.
 - iv. Touch Downconverter. This selects the direct measurement into the downconverter.
5. Press **Setup**.

Note	There are different bands in the E5053A that need to be manually set.
-------------	---

- a. Touch Frequency Band.
 - i. If the test frequencies is from 10 MHz to 40 MHz, touch 10M - 41MHz.
 - ii. If the test frequencies is from 39 MHz to 101 MHz, touch 39M - 101MHz.
 - iii. If the test frequencies is from 99 MHz to 1.5 GHz, touch 99M - 1.5GHz.
 - iv. If the test frequencies is from 250 MHz to 5 GHz, touch 250M - 7GHz.
 - v. If the test frequencies is from > 5 GHz to 10 GHz (requires downconverter is on and is the selected input), touch 3G - 10GHz.
 - vi. If the test frequencies is from 9 GHz to 26.5 GHz (requires downconverter is on and is the selected input), touch 9G - 26.5GHz.
 - b. Set IF Gain to:
 - i. 50 dB if DUT CW frequency < 5 GHz.
 - ii. 20 dB if DUT CW frequency ≥ 5 GHz.
 - c. Touch nominal frequency and enter the test frequency from the test record.
6. Press ATTN.
- a. Set to 0 dB if DUT CW frequency < 5 GHz.
 - b. Verify attenuation is set to 10 dB if DUT CW frequency ≥ 5 GHz
7. Hit Trigger
- a. Touch Continuous.

- b. Touch Single. At the upper right of the screen the E5052B should have the approximate test frequency displayed, see [Figure 3-4](#).

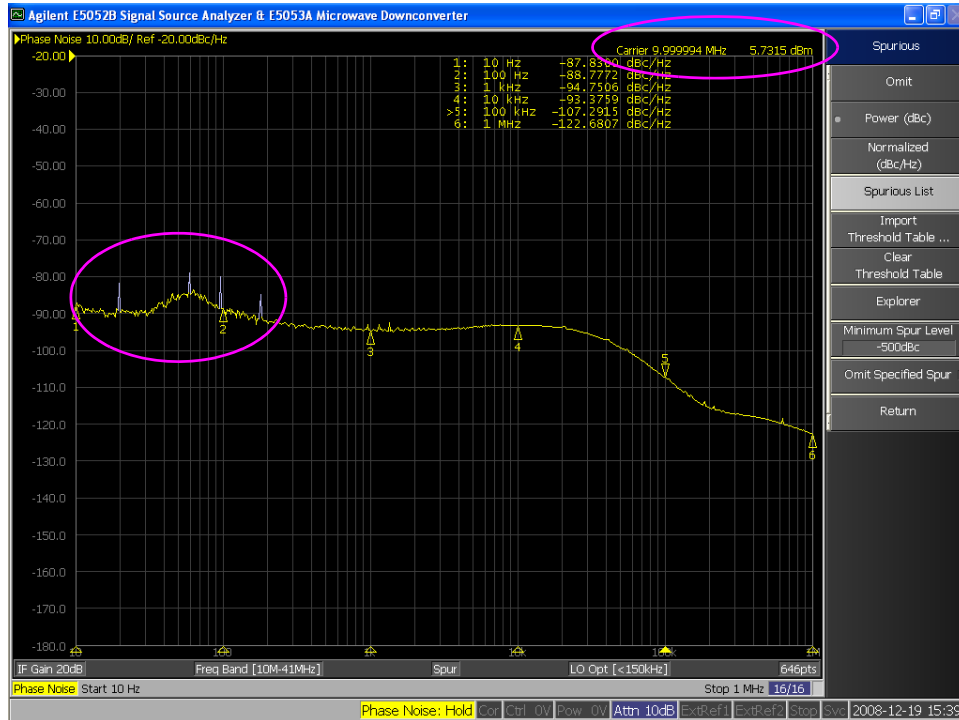

Figure 3-4. E5052B Display

8. Press **Trace/View**.

- a. Touch **Spurious**.
- b. Touch **Power (dBc)**. Now white spikes may appear on the screen indicating the spurs, see [Figure 3-4](#).
- c. Touch **Spurious List** and a new screen will appear.
- d. This screen gives the spurious signal's frequency and power levels. The format is:
Frequency in hertz , Power level in dBc

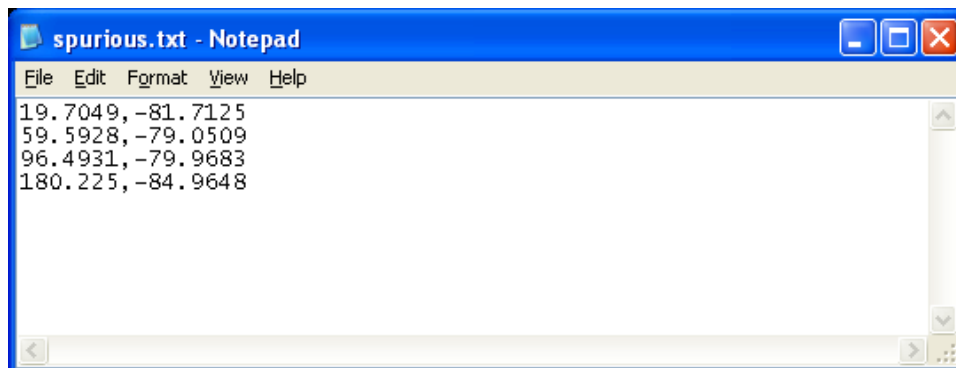

Figure 3-5. Spurious List

9. Compare these values to the appropriate frequency in the test records for “Single Sideband Phase Noise Test: Power Line and Fan Rotation Emissions”. Record any values which are out of specification.
10. Close the Spurious List window.
11. Press **Trace/View**.
 - a. Touch **Spurious** (note: it may be required to touch the down arrow at the bottom of the right screen to locate).
 - b. Touch **OMIT**.



Figure 3-6. Phase Noise/Marker Values

12. Record phase noise/marker values into the test records. .

Note Note not all markers are used without option 3 or 30

13. Refer to the next frequency in the Single Sideband Phase Noise Test.
14. Press **Trigger**.
 - Touch **Continuous**.
15. Go to step 2 and repeat this until all test frequencies are verified for the particular model and option configuration under test.

AeroFlex PN9000 Phase Noise System

The section below contains the information to perform the verification using the The AeroFlex PN9000 phase noise system.

The following test can be used to verify that the MG369xB meets its single sideband phase noise specifications. For this test, an Anritsu MG3694A or B (with Options 3 and 4) signal generator is required to act as a local oscillator (LO). [Table 3-3](#) lists the single side band requirements for the local oscillator.

The CW RF output of the MG369xB under test (DUT) is mixed with the CW RF output from the MG3694B LO, which is offset by 100 MHz. Single sideband phase noise is measured at offsets of 10 Hz, 100 Hz, 1 kHz, 10 kHz, 100 kHz, and 1 MHz away from the resultant 100 MHz IF.

Table 3-3. Single Side Band Requirements for Local Oscillator

Frequency Range	Offset From Carrier					
	10 Hz	100 Hz	1 kHz	10 kHz	100 kHz	1 MHz
≥ 10 MHz to ≤ 15.625 MHz	-105	-126	-139	-142	-141	-145
> 15.625 MHz to ≤ 31.25 MHz	-99	-120	-134	-137	-137	-145
> 31.25 MHz to ≤ 62.5 MHz	-90	-114	-129	-136	-136	-144
> 62.5 MHz to ≤ 125 MHz	-88	-108	-127	-135	-133	-144
> 125 MHz to ≤ 250 MHz	-84	-102	-125	-132	-130	-143
> 250 MHz to ≤ 500 MHz	-77	-99	-123	-125	-124	-142
> 500 MHz to ≤ 1050 MHz	-71	-93	-118	-121	-119	-138
> 1050 MHz to ≤ 2200 MHz	-66	-86	-112	-115	-113	-135
> 2.2 GHz to ≤ 6 GHz	-54	-77	-104	-108	-107	-130
> 6 GHz to ≤ 10 GHz	-52	-73	-100	-107	-107	-128
> 10 GHz to ≤ 20 GHz	-45	-68	-94	-102	-102	-125
> 20 GHz to ≤ 40 GHz	-45	-63	-92	-98	-98	-119

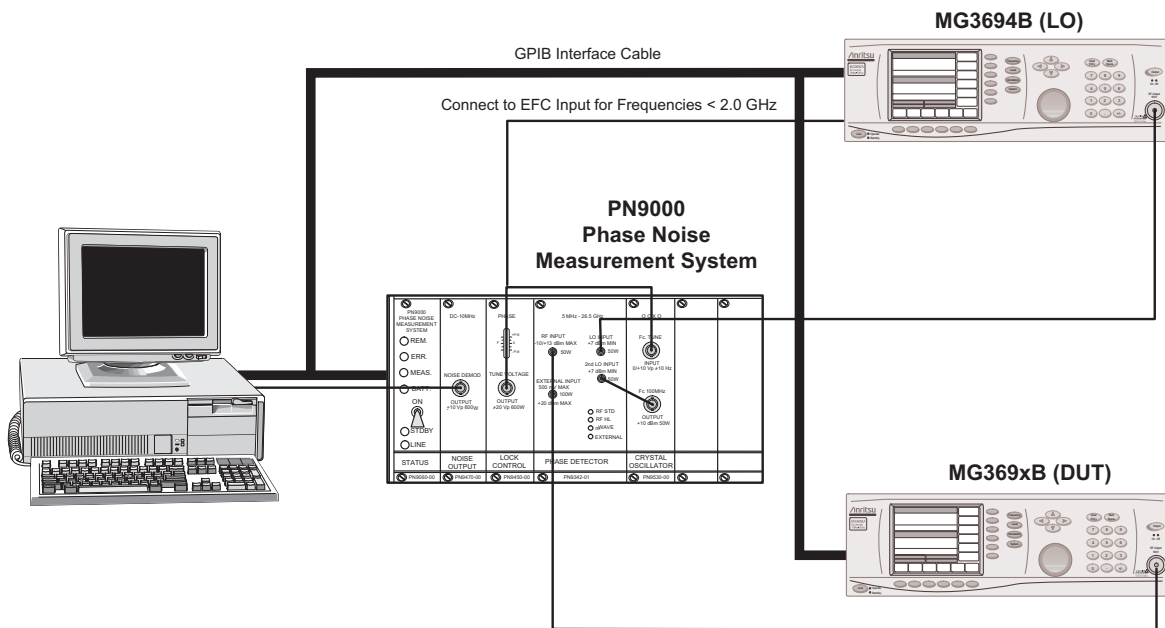

Figure 3-7. Equipment Setup for Single Sideband Phase Noise Test with AeroFlex PN9000 Phase Noise System

Test Setup

The PN9000 software must be installed and set up in accordance with the instructions supplied with the phase noise measurement system before continuing with this procedure.

Note Before performing this procedure ensure that all test equipment is calibrated. Refer to the manufacturer's test equipment manual.

Connect the equipment, shown in [Figure 3-7](#), as follows:

1. Connect a GPIB interface cable from the PN9000 system to the MG3694B (LO) rear panel IEEE-488 GPIB connector.
2. Connect a GPIB interface cable from the PN9000 system to the MG369xB (DUT) rear panel IEEE-488 GPIB connector.
3. Connect the MG3694B (LO) RF Output to the LO INPUT of the PN9000 phase detector module.
4. Connect the MG369xB (DUT) RF Output to the RF INPUT of the PN9000 phase detector module.
5. On the PN9000 system, connect the Fc. 100 MHz OUTPUT of the crystal oscillator module to the 2nd LO INPUT of the phase detector module.
6. On the PN9000 system, connect the TUNE VOLTAGE OUTPUT of the lock control module to the Fc. TUNE INPUT of the crystal oscillator module.

Test Procedure

The following procedure verifies the RF output single sideband phase noise levels to specification.

1. Set the MG369xB (DUT) GPIB address as follows:
 - a. Press **System**, then **Config**. The System Configuration menu is displayed.
 - b. Press **GPIB** to display the Configure GPIB menu.
 - c. Press **GPIB Address** to change the current address of the MG369xB (DUT).
 - d. Enter a new address using the cursor control key or the data entry keypad and the **Enter** terminator key.
 - e. The new address will appear on the display. The entry must be between 1 and 30 to be valid.
2. Set the MG3694B (LO) GPIB address by following the procedure in step 1. The GPIB address must be different from the one set for the MG369xB (DUT) in step 1.
3. Set up the PN9000 system as follows:
 - a. Select the **Measure/Graph** menu:
 - (1) Set Log. Fmin = 10 Hz
 - (2) Set Log. Fmax = 1 MHz
 - (3) Set Level max = -40 dB
 - (4) Set Level min = -150 dB
 - b. Select the **Status/Average** menu:
 - (1) Set Average = On
 - (2) Set 10/100Hz = 10
 - (3) Set 100/1kHz = 20
 - (4) Set 1k/10kHz = 20
 - (5) Set 10k/100kHz = 20
 - (6) Set 100k/1MHz = 20

- c. Set “Vcontrol = 5 Volts” (in the bottom status bar) by pressing the following on the keyboard:
Tab | Enter | 5 | Enter
This sets the “VCO-100MHz” frequency tune control to the middle of its range.
- d. Select the Calib/Input menu:
- (1) Set Source RF driver to Wiltron 6700.
 - (2) Set Source LO driver to Wiltron 6700.
 - (3) Set Offset LO to the value stated in [Table 3-4 on page 3-21](#) for the current test frequency.
 - (4) Set RF Phase Detection to the mode stated in [Table 3-4](#) for the current test frequency.
 - (5) For test frequencies greater than 1.8 GHz, set RF Phase Detection = Transposition.
For test frequencies less than 1.8 GHz, set RF Phase Detection = Standard 5 dBm and connect the LO EFC to the PN9000 Tune Voltage using a BNC tee.

Note

When measuring frequencies less than 1.8 GHz, the Tune Voltage on the PN9000 must also be connected to the LO EFC input.

- e. Select the Calib/RF menu:
- (1) Set Freq = to the frequency indicated in the test record.
 - (2) Set Level = Value stated in [Table 3-4](#) for the current test frequency.
 - (3) Set the GPIB address to the DUT GPIB address.
- f. Select the Calib/LO menu:
- (1) Set Freq = Frequency stated in [Table 3-4](#) for the current test frequency.
 - (2) Set Level = Value stated in [Table 3-4](#) for the current test frequency.
When you exit the Calib/LO menu, the offset is automatically added to the LO frequency (displayed in the bottom status bar).
 - (3) Set the GPIB address to the LO GPIB address.
- g. Select the Calib/VCO menu:
- (1) For test frequencies greater than 1.8 GHz, set VCO1 = 100 MHz on.
For test frequencies less than 1.8 GHz, set VCO1 = Off.
- h. Select the Calib/Fcounter menu:
- (1) Select Freq IF and press <Enter>.
A frequency close to the difference of the RF and LO frequencies is displayed in the menu item.
 - (2) Press Esc to exit the menu.
- i. Press the CTRL + F keys to obtain a frequency beat. A very low frequency beat (<10 Hz) should be obtained, indicating that the correct carrier frequency is programmed.
4. Calibrate and lock the PN9000 system as follows:
- a. Select the Lock/Def. Loop menu:
- (1) Set Loop BW = Value stated in [Table 3-4](#) for the current frequency parameter.
 - (2) Set Tune Slope = Value stated in [Table 3-4](#) for the current frequency parameter.
 - (3) Set Maximum BW = Value stated in [Table 3-4](#) for the current frequency parameter.

- b.** Offset the frequency of the MG369xB (DUT) as follows:
 - (1) Press **Local** to return the instrument to local control.
 - (2) Offset the frequency by 1 kHz.
- c.** On the PN9000 system, select the **Calib/Exec Cal** menu, then select **OK**.
- d.** After calibration, remove the 1 kHz offset on the MG362XB (DUT), then press **<Enter>** to continue.
- e.** For test frequencies greater 1.8 GHz, select the **Lock/AutoLock** menu:
 - (1) Set $V_{min} = 0$ V
 - (2) Set $V_{max} = +10$ V
 - (3) Select **OK MWAVE** to perform the automatic locking process. The system will check that conditions for locking are met, measure the tune slope of the reference source, and look for the locking voltage.
 - (4) When this process completes, press **<Enter>** to continue.

For test frequencies less than 1.8 GHz, select **Lock/ExecLock** to lock the PN9000 system.

- 5.** On the PN9000 system, select the **Measure** menu, then select **OK** to perform the measurement. When prompted for curve name, press **N** for no.
- 6.** When the measurement completes, select the **Process/Marker** menu:
 - a.** Set **Marker** = curveM
 - b.** Set **Type** = Vert.line
 - c.** Set **Color** = Green (or color of choice)
 - d.** Select **OK** and press **Esc**.
- 7.** Use the arrow keys on the keyboard to move the marker to the desired frequency offset (displayed on the lower right of the screen).

Note	For test frequencies less than 1.8 GHz, select Lock/Lock Off to turn off locking prior to testing the next test frequency.
-------------	---

- 8.** Record the displayed phase noise levels at the following offsets from the carrier:
 - 10 Hz (units with Option 3 or 30)
 - 100 Hz (all units)
 - 1 kHz (all units)
 - 10 kHz (all units)
 - 100 kHz (all units)
 - 1 MHz (units with Option 3 or 30)
- 9.** Record any power line and fan rotation spurious emissions above the specified limits in the test record.
- 10.** Repeat steps 3 through 9 for all frequencies listed in the test record.

Table 3-4. PN9000 Phase Noise Test

Test Frequency	15 MHz	30 MHz	60 MHz	120 MHz	250 MHz	499 MHz	600 MHz	1.99 GHz	
Notes:	Option 4 Only						Option 5 Only		
Calib/Input Menu:									
LO Offset	0 Hz	0 Hz	0 Hz	0 Hz	0 Hz	0 Hz	0 Hz	100 MHz	
Phase Detection	Standard	Standard	Standard	Standard	Standard	Standard	Standard	Transposition	
Calib/RF Menu:									
RF Frequency	15 MHz	30 MHz	60 MHz	120 MHz	250 MHz	499 MHz	600 MHz	1.99 GHz	
Power Level	10 dBm	10 dBm	10 dBm	10 dBm	10 dBm	10 dBm	10 dBm	10 dBm	
Calib/LO Menu:									
LO Frequency	15.1 MHz	30.1 MHz	60.1 MHz	120.1 MHz	250.1 MHz	499.1 MHz	600.1 MHz	2.09 GHz	
Power Level	10 dBm	10 dBm	10 dBm	10 dBm	10 dBm	10 dBm	10 dBm	10 dBm	
Lock/Define Loop Menu:									
Loop BW	10 Hz	75 Hz	86 Hz	75 Hz	75 Hz	90 Hz	100 Hz	100 Hz	
Tune Slope	40 Hz/V	40 Hz/V	86 Hz/V	172 Hz/V	172 Hz/V	333 Hz/V	420 Hz/V	210 Hz/V	
Max BW	320 Hz	320 Hz	320 Hz	320 Hz	320 Hz	320 Hz	320 Hz	2 kHz	
Test Frequency	2.01 GHz	2.19 GHz	2.21 GHz	6 GHz	8 GHz	10 GHz	19.99 GHz	20.01 GHz	25 GHz
Notes:	All Models without Option 4	Models with Option 4 Only		All Models	MG3691B Only	All Models	All Models > 10 GHz	All Models > 20 GHz Only	
Calib/Input Menu:									
LO Offset	0 Hz	0 Hz	0 Hz	-100 MHz	-100 MHz	-100 MHz	-100 MHz	-100 MHz	-100 MHz
Phase Detection	Transposition	Transposition	Transposition	Transposition	Transposition	Transposition	Transposition	Transposition	Transposition
Calib/RF Menu:									
RF Frequency	2.01 GHz	2.19 GHz	2.21 GHz	6 GHz	8 GHz	10 GHz	19.99 GHz	20.01 GHz	25 GHz
Power Level	The lesser of +10 dBm or maximum specified leveled output power								
Calib/LO Menu:									
LO Frequency	1.91 GHz	2.09 GHz	2.11 GHz	6 GHz	8 GHz	10 GHz	19.99 GHz	20.01 GHz	25 GHz
Power Level	The lesser of +10 dBm or maximum specified leveled output power								
Lock/Define Loop Menu:									
Loop BW	100 Hz	100 Hz	100 Hz	100 Hz	100 Hz	100 Hz	100 Hz	100 Hz	100 Hz
Tune Slope	210 Hz/V	210 Hz/V	210 Hz/V	210 Hz/V	210 Hz/V	210 Hz/V	210 Hz/V	210 Hz/V	210 Hz/V
Max BW	2 kHz	2 kHz	2 kHz	2 kHz	2 kHz	2 kHz	2 kHz	2 kHz	2 kHz

3-9 Power Level Accuracy and Flatness Tests

The following tests can be used to verify that the MG369xB meets its power level specifications. Power level verifications are divided into four parts: log conformity, power level accuracy (to -50 dBm), power level accuracy (-50 dBm to -100 dBm), and power level flatness. Accurate power level measurements below -100 dBm are not currently feasible.

Note

Before performing this procedure ensure that all test equipment is calibrated. Refer to the manufacturer's test equipment manual.

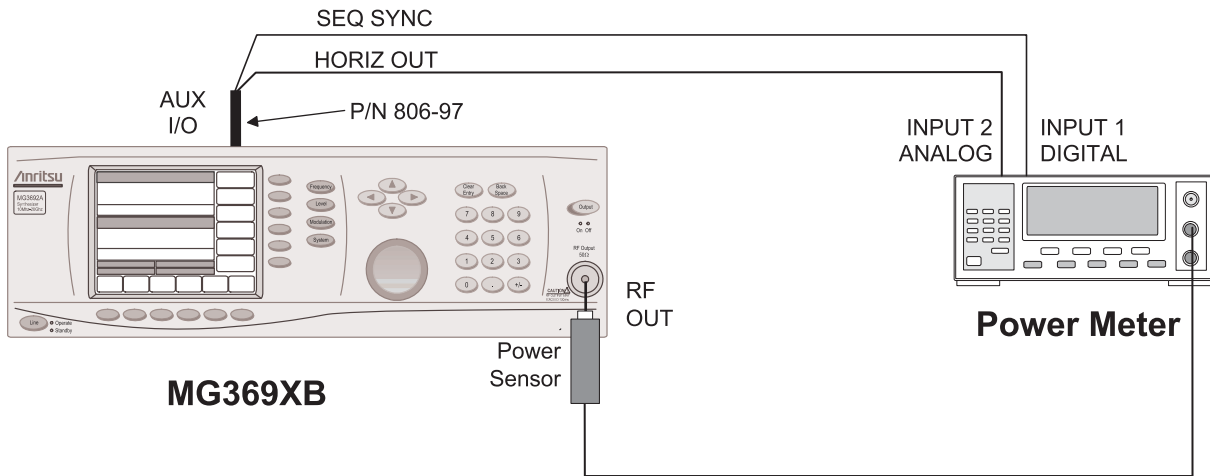

Figure 3-8. Equipment Setup for Power Level Accuracy and Flatness Tests Above -50 dBm

Test Setup

For all power level measurements above -50 dBm, connect the equipment, shown in [Figure 3-8](#), as follows:

Caution

To prevent damage to the power sensor, use a fixed attenuator when measuring power levels above $+19$ dBm.

1. Calibrate the power meter with the appropriate power sensor.

Note

On MG3696B units install the SC7430 or SC7570 at test frequencies ≥ 60 GHz.

2. Connect the power sensor to the RF Output of the MG369xB (use a fixed attenuator when measuring power levels above $+19$ dBm).
3. Connect the special AUX I/O interface cable (Anritsu PN: 806-97) to the MG369xB rear panel AUX I/O connector. Connect the cable BNC connectors as follows:
 - a. Connect the cable labeled "SEQ SYNC" to the power meter rear panel INPUT 1 DIGITAL connector.
 - b. Connect the cable labeled "HORIZ OUT" to the power meter rear panel INPUT 2 ANALOG connector.

Power Level Log Conformity

The log conformity test verifies the dynamic range and level accuracy of the Automatic Level Control (ALC) loop. Power level log conformity is tested in both pulse (if equipped) and non-pulse modes by stepping the output power level down in 1 dB increments from its maximum rated power level and measuring the output power level at each step.

1. Set up the power meter as follows:
 - a. Reset the power meter by pressing:
System | Setup | -more- | PRESET | RESET
 - b. Configure the power meter to perform power measurements by pressing:
Sensor | Setup | MODE | Default
 - c. Configure the power sensor's calibration factor source by pressing:
Sensor | CalFactor | SOURCE | V/GHz until V/GHz is displayed.
 - d. Setup the minimum V/GHz range by pressing:
Setup | Start F
 - e. Enter the minimum frequency of the MG under test or minimum of the power meter.
 - f. Setup the maximum V/GHz range by pressing:
Setup | Stop F
 - g. Enter the maximum frequency of the MG under test or maximum of the power meter.
 - h. Press any hard key to begin the measurement.

Caution To prevent damage to the power sensor, use a fixed attenuator when measuring power levels above +19 dBm.

2. Set up the MG369xB as follows:
 - a. Reset the instrument by pressing **SYSTEM**, then **Reset**. After reset, the CW menu is displayed.
 - b. If the DUT has a step attenuator (Option 2):
 - (1) Press **Level** to open the Level Control menu.
 - (2) Press **ALC Mode**, then press **Attenuate>** to open the Attenuator Control menu.
 - (3) Press **Decouple** to decouple the attenuator from the ALC loop.
 - c. Press **Frequency** to open the current frequency parameter for editing.
 - d. Set F1 to the CW frequency indicated in the test record.
 - e. Press **Edit L1** to open the current power level parameter for editing.
 - f. Set L1 to the first applicable power level indicated in the test record.

Note For models with Option 22, rated output power is reduced by 2 dB.

3. Measure the output power level with the power meter and record the reading in the test record.
4. On the MG369xB, use the cursor control key (Arrow keys) to decrement L1 to the next test power level in the test record. Measure and record the power meter reading in the test record.
5. Repeat step 4 for each of the test power levels listed in the test record for the current CW frequency.
6. Repeat steps 2c through 5 for all CW frequencies listed in the test record.

7. For models with external pulse modulation:
 - a. Press **Modulation** to open the Modulation menu.
 - b. Press **Pulse**, then select external pulse mode by pressing **Internal/External**, if required.
 - c. Turn the pulse mode on by pressing **On/Off**.
 - d. Repeat steps 2c through 6.

Power Level Accuracy (≥ -50 dBm)

Power level accuracy for power levels of -50 dBm and above are tested by stepping the output power level down in 5 dB increments from its maximum rated power level and measuring the output power level using a power meter at each step.

1. Set up the power meter as follows:
 - a. Reset the power meter by pressing:
System | Setup | -more- | PRESET | RESET
 - b. Configure the power meter to perform power measurements by pressing:
Sensor | Setup | MODE | Default
 - c. Configure the power sensor's calibration factor source by pressing:
Sensor | CalFactor | SOURCE | V/GHz, until V/GHz is displayed.
 - d. Setup the minimum V/GHz range by pressing:
Setup | Start F
 - e. Enter the minimum frequency of the MG under test or minimum of the power meter.
 - f. Setup the maximum V/GHz range by pressing:
Setup | Stop F
 - g. Enter the maximum frequency of the MG under test or maximum of the power meter.
 - h. Press any hard key to begin the measurement.
2. Set up the MG369xB as follows:
 - a. Reset the instrument by pressing **SYSTEM**, then **Reset**. After reset, the CW menu is displayed.
 - b. Press **Edit F1** to open the current frequency parameter for editing.
 - c. Set F1 to the CW frequency indicated in the test record.
 - d. Press **Edit L1** to open the current power level parameter for editing.
 - e. Set L1 to the power level indicated in the test record.
3. Measure the output power level with the power meter and record the reading in the test record.
4. On the MG369xB, use the cursor control key (Arrow keys) to decrement L1 to the next test power level in the test record. Measure and record the power meter reading in the test record.
5. Repeat step 4 for each of the test power levels listed in the test record (down to -50 dBm) for the current CW frequency.
6. Repeat steps 2b through 5 for all CW frequencies listed in the test record.

Power Level Accuracy (< -50 dBm)

Power level accuracy for power levels below -50 dBm is tested in two methods. First, by measuring the MG369xB's RF output directly on a measuring receiver; second, by down converting the MG369xB's RF output and measuring the down converted IF on a measuring receiver. In both cases, a reference power level is set on the measuring receiver and the output power level is stepped down in 5 dB increments. The relative output power level is then measured at each step.

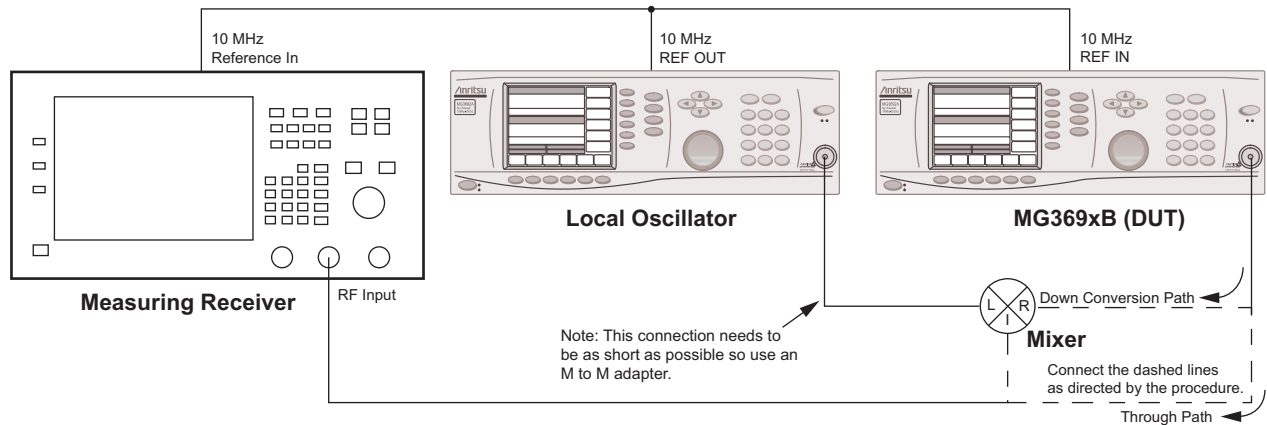

Figure 3-9. Equipment Setup for Power Level Accuracy and Flatness Tests Below -50 dBm

Test Setup

For all power level measurements below -50 dBm, connect the equipment, shown in [Figure 3-9](#), as follows:

1. Ensure the ML2530 receiver is calibrated by performing the range cal for the following frequency points: 8.51 MHz, 10 MHz, 15 MHz, 60 MHz, 500 MHz, 600 MHz, 1 GHz and 2 GHz
The calibration should include ranges 1 to 3 with a bandwidth of 10 Hz.
2. For RF frequencies below 2400 MHz, connect the MG369xB RF Output to the RF input of the measuring receiver.
3. For RF frequencies above 2400 MHz:
 - a. Connect the RF Output of the LO and the MG369xB to the mixer's (PN: 60-114) L-port and R-port, respectively, using low loss cables.
 - b. Connect the mixer's I-port to the RF input of the measuring receiver.
4. Using a BNC tee, connect the 10 MHz reference output from the measuring receiver to the MG369xB's and local oscillator's 10 MHz REF IN connectors.
5. If using the T2579 Mixer box, see [Figure 3-10 on page 3-26](#).
 - a. Connect the Measuring receiver to the IF port on the T2579 Mixer box.
 - b. Connect the MG3690B DUT output to the DUT port on the T2579.
 - c. Connect the LO output to the LO port on the T2579.
 - d. Connect a Low Pass Filter and BNC cable to the HI port on the T2579 Mixer box, then connect the other end to the HI BNC or HI Band connector at rear panel of the LO.
 - e. Connect a Low Pass Filter and BNC cable to the LO port on the T2579 Mixer box, then connect the other end to the LO BNC or LO Band connector at rear panel of the LO.

Note

if using the T2579 mixer box moving the cables is not required because the T2579 box automatically connects to the proper locations.

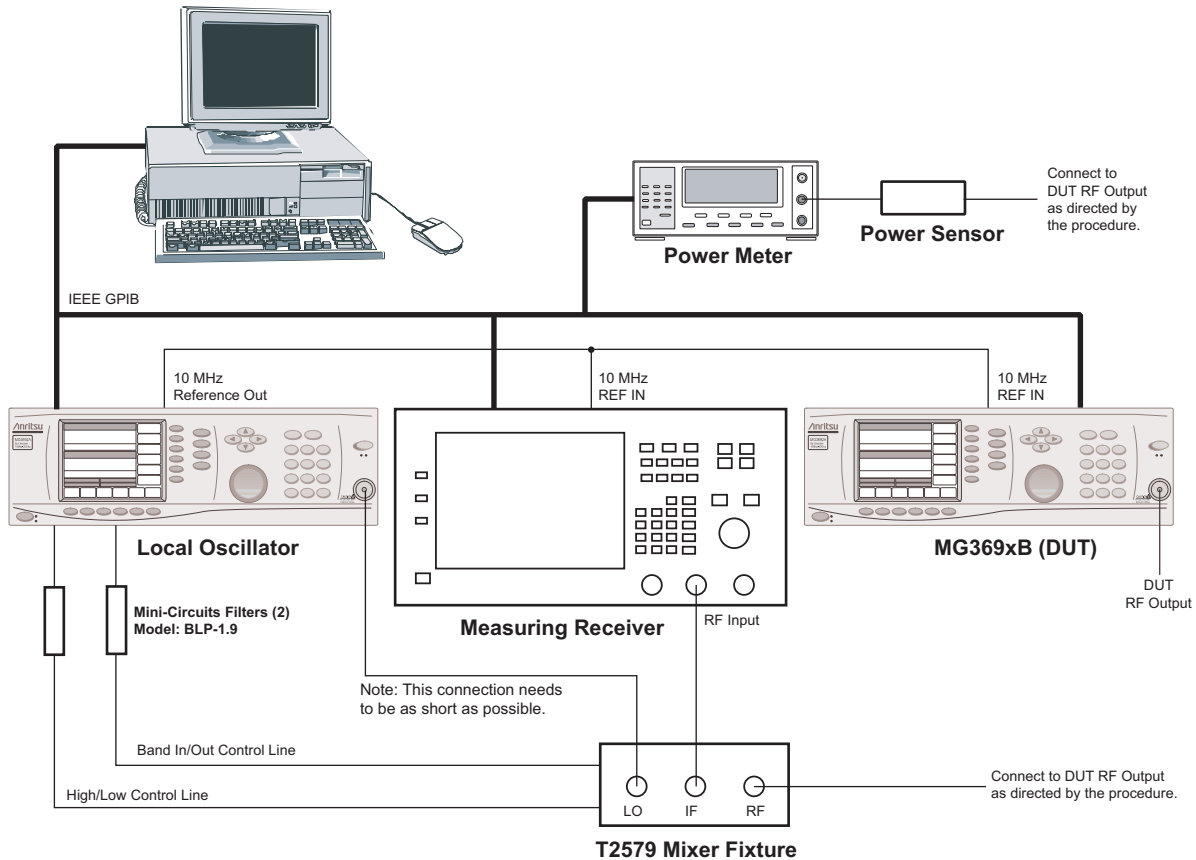

Figure 3-10. Level Cal Setup using T2579 Mixer Fixture

Test Procedure

The following procedure lets you verify the power accuracy and flatness for all power level measurements below -50 dBm.

1. Initial setup of the MG369xB as follows:
 - a. Reset the instrument by pressing **SYSTEM**, then Reset. After reset, the CW menu is displayed.
2. Initial setup of the LO:
 - a. Reset the instrument by pressing **System**, then Reset. After reset, the CW menu is displayed.
 - b. Press **Edit L1** to open the current power level parameter for editing.
 - c. Set L1 to $+6$ dBm.
3. Initial setup of the Measurement Receiver:
 - a. Reset the receiver by pressing the **Preset** key.
 - b. Press the **Freq** key, then select Frequency Span and enter 10 kHz.
 - c. Press the **BW** key, then select Manual and enter 10 Hz.
4. Setup the MG369xB as follows:
 - a. Press **Edit F1** to open the current frequency parameter for editing.
 - b. Set F1 to the CW frequency indicated in the test record.
 - c. Press **Edit L1** to open the current power level parameter for editing.
 - d. Set L1 to -40 dBm.

5. If measuring frequencies below 2400 MHz, connect the MG369xB RF Output directly to the measuring receiver's RF input and skip to step 7.
6. If measuring frequencies above 2400 MHz, connect the MG369xB RF Output to the mixer's R-input port and set up the LO as follows:
 - a. Press **Edit F1** to open the current frequency parameter for editing.
 - b. Set **F1** to the LO CW frequency indicated in the test record.
 - c. Set **L1** based on frequencies list:
 - i. ≤ 10 GHz leave the power at +13 dBm.
 - ii. ≥ 10 GHz but \leq to 20 GHz set power to +12 dBm.
 - iii. > 20 GHz set power to +6 dBm.

Note	When measuring frequencies above 2400 MHz, the LO, DUT, and measuring receiver should be connected to the mixer and the measuring receiver should be set to measure 8.51 MHz.
-------------	---

7. Set up the measuring receiver as follows:
 - a. Press the **Freq** key and enter the CW frequency listed in the test record.
 - b. Press the **Offset** key, select the offset value, enter 0.
 - c. Read the measured value and calculate the line and mixer loss offset as follows:
(Test record reading at -40 dBm for the current test frequency) – Receiver Reading = Offset
The offset value should be a positive number.
 - d. Press the **Offset** key and select **Offset On**.
 - e. Select **Offset Value** and enter the offset value that was calculated above. The displayed reading on the measuring receiver should be the test record reading at -40 dBm for the current test frequency. If not, repeat steps b through e.
8. On the MG369xB, set **L1** to the power level indicated in the test record starting with -55 dBm.

Note	When making power level changes greater than 15 dB, the first measurement should be thrown out to allow for the measuring receiver to auto range.
-------------	---

9. Measure the relative output power level and record the reading into the test records.
10. Repeat steps 8 and 9 for each of the test power levels listed in the test record for the current CW frequency.

Note	Depending on options and model numbers not all levels in the test records are tested. The lowest level measured is 100 dB below the maximum leveled power. In some cases measurement at or below -75 dBm is not required. Refer to the Technical Data Sheet for maximum leveled power specification and subtract 100 dB. This will determine the lowest value to measure.
-------------	---

11. Repeat steps 4 through 10 for all CW frequencies listed in the test record.

Note	Frequencies above 40 GHz are not measured using the calibrated receiver and mixer.
-------------	--

Power Level Flatness

Power level flatness is tested by measuring the output power level variation during a full band sweep in the manual sweep mode.

Test Setup

For all power level flatness measurements connect the equipment, shown in [Figure 3-8 on page 3-22](#), as follows:

Caution To prevent damage to the power sensor, use a fixed attenuator when measuring power levels above +19 dBm.

1. Calibrate the power meter with the appropriate power sensor.
2. Connect the power sensor to the RF Output of the MG369xB (use a fixed attenuator when measuring power levels above +19 dBm).
3. Connect the special AUX I/O interface cable (Anritsu Part No. 806-97) to the MG369XB rear panel AUX I/O connector. Connect the cable BNC connectors as follows:
 - a. Connect the cable labeled “SEQ SYNC” to the power meter rear panel INPUT 1 DIGITAL connector.
 - b. Connect the cable labeled “HORIZ OUT” to the power meter rear panel INPUT 2 ANALOG connector.
4. Set up the power meter as follows:
 - a. Reset the power meter by pressing:
System | Setup | -more- | PRESET | RESET
 - b. Configure the power meter to perform power measurements by pressing:
Sensor | Setup | MODE
until Default is displayed.
 - c. Configure the power sensor’s calibration factor source by pressing:
Sensor | CalFactor | SOURCE
until V/GHz is displayed.
 - d. Setup the minimum V/GHz range by pressing:
Setup | Start F
 - e. Enter the lower frequency of the MG369xB under test using the value in the frequency range column of the test record.
 - f. Setup the maximum V/GHz range by pressing:
Setup | Stop F
 - g. Enter the upper frequency of the MG369xB under test using the value in the frequency range column of the test record.
 - h. Press any hard key to begin the measurement.

Caution To prevent damage to the power sensor, use a fixed attenuator when measuring power levels above +19 dBm.

Test Procedure

1. Set up the MG369xB as follows:
 - a. Reset the instrument by pressing **SYSTEM**, then **Reset**. The CW menu is displayed.
 - b. Press **Manual Sweep** to place the instrument in the manual sweep frequency mode and to display the Manual Sweep menu.
 - c. With the Manual Sweep menu displayed, press the **Frequency Control** soft key.
 - d. The Manual Sweep Frequency Control menu is then displayed.
 - e. The minimum or maximum frequencies are based on the power sensor performance, model, options installed, and specifications.
 - i. Press **F1 - F2**.
 - ii. Press **Edit F1**, enter the lower frequency of the MG369xB under test using the next frequency range value in the test record.
 - iii. Press **Edit F2**, enter the upper frequency of the MG369xB under test using the next frequency range value in the test record.
 - f. Press **Edit L1** to open the current power level parameter for editing.
 - g. Set **L1** to the power level indicated in the test record.
 - h. Return to the Manual Sweep menu by pressing the **<Previous** soft key.
 - i. At the Manual Sweep menu, press **Number of Steps** to open the number-of-steps parameter for editing.
 - j. Enter the number of steps called out in the test records.
 - k. Press the **Frequency Control** soft key.

Note Be sure to use and calibrate the appropriate power sensor for the frequency being measured.

2. Using the rotary data knob, sweep the MG369xB through the frequency range. Measure the maximum and minimum power meter readings and record the variation (difference between the maximum and minimum readings) in the test record. Verify that the variation does not exceed the specification noted in the test record.
3. Setup the power meter for the next measurement.
 - a. Configure the power sensor's calibration factor source by pressing:
Sensor | CalFactor | SOURCE
until **V/GHz** is displayed.
 - b. Setup the minimum **V/GHz** range by pressing:
Setup | Start F
 - c. Enter the lower frequency of the MG369xB under test using the next frequency range value in the test record.
 - d. Setup the maximum **V/GHz** range by pressing:
Setup | Stop F
 - e. Enter the upper frequency of the MG369xB under test using the next frequency range value in the test record.
 - f. Press any hard key to begin the measurement.
4. Repeat steps 1b through 3 until all tests are completed in the test record.

Maximum Leveled Power

Maximum leveled power is tested by measuring the output power level during a full band sweep in the manual sweep mode.

Test Setup

Note	To prevent damage to the power sensor, use a fixed attenuator when measuring power levels above +19dBm.
-------------	---

1. Connect the equipment as shown in [Figure 3-8 on page 3-22](#).
2. Calibrate the power meter with the appropriate power sensor.
3. Connect the power sensor to the RF Output of the MG369xB (use a fixed attenuator when measuring power levels above +19 dBm).
4. Connect the special AUX I/O interface cable (Anritsu PN: 806-97) to the MG369xB rear panel AUX I/O connector. Connect the cable BNC connectors as follows:
 - a. Connect the cable labeled “SEQ SYNC” to the power meter rear panel INPUT 1 DIGITAL connector.
 - b. Connect the cable labeled “HORIZ OUT” to the power meter rear panel INPUT 2 ANALOG connector.
5. Set up the power meter as follows:
 - a. Reset the power meter by pressing:
System | Setup | -more- | PRESET | RESET
 - b. Configure the power meter to perform power measurements by pressing:
Sensor | Setup | MODE
until Default is displayed.
6. Configure the power sensor's calibration factor source by pressing:
Sensor | CalFactor | SOURCE | V/GHz until V/GHZ is displayed
 - a. Setup the minimum V/GHz range by pressing:
Setup | Start F
Enter the lower frequency of the MG369xB under test using the value in the frequency range column of the test record.
 - b. Setup the maximum V/GHz range by pressing
Setup | Stop F
Enter the upper frequency of the MG369xB under test using the value in the frequency range column of the test record.
 - c. Press any hard key to begin the measurement.

Test Procedure

1. Set up the MG369xB for a manual sweep as follows:
 - a. Reset the instrument by pressing **SYSTEM**, then **Reset**. The CW menu is displayed.
 - b. Press **Manual Sweep** to place the instrument in the manual sweep frequency mode and to display the Manual Sweep menu.
 - c. With the Manual Sweep menu displayed, press the **Frequency Control** soft key.
 - d. The Manual Sweep Frequency Control menu is then displayed.
 - e. The minimum or maximum frequencies are based the power sensor performance, model, options installed, and specifications.
 - i. Press **F1 - F2**.
 - ii. Press **Edit F1**, enter the lower frequency of the MG369xB under test using the next frequency range value in the test record.
 - iii. Press **Edit F2**, enter the upper frequency of the MG369xB under test using the next frequency range value in the test record.

Note Be sure to use and calibrate the appropriate power sensor for the frequency being measured.

- f. Press **Edit L1** to open the current power level parameter for editing.
 - g. Set **L1** to the power level noted in the test record.
 - h. Return to the Manual Sweep menu by pressing the **<Previous** soft key.
 - i. On the Manual Sweep menu, press the **Num of Steps** soft key to open the number-of-steps parameter for editing.
 - j. Set the number-of-steps to 200.
 - k. Press the **Frequency Control** soft key.
2. Using the rotary data knob, sweep the MG369xB through the full frequency range. Measure the minimum power meter readings and record the values in the test record. Verify that the minimum readings exceed the value noted in the test record.
3. Setup the power meter for the next measurement.
 - a. Configure the power sensor's calibration factor source by pressing:
Sensor | CalFactor | SOURCE
until **V/GHz** is displayed.
 - b. Setup the minimum **V/GHz** range by pressing:
Setup | Start F
 - c. Enter the lower frequency of the MG369xB under test using the next frequency range value in the test record.
 - d. Setup the maximum **V/GHz** range by pressing:
Setup | Stop F
 - e. Enter the upper frequency of the MG369xB under test using the next frequency range value in the test record.
 - f. Press any hard key to begin the measurement.
4. Repeat steps 1b through 3 until all tests are completed in the test record.

3-10 Frequency Modulation and Phase Modulation Tests

This section provides a manual procedure to verify the performance of the frequency and phase modulation of the MG369xB.

The test methodology is the RF output of the MG369xB is modulated on and off while monitored on a Spectrum Analyzer display. The FM accuracy is determined by measuring the delta of Carrier Wave (FM/ Φ M on and FM/ Φ M off). This delta is converted to modulation index by applying Inverse Bessel Null, Taylor Series and Newton's Method for Finding Roots calculations. The modulation index is then converted to the actual deviation or dB. These tests quantify how the modulating input signal affects the signal generator's RF output.

Note

Before performing this procedure ensure that all test equipment is calibrated. Refer to the manufacturer's test equipment manual.

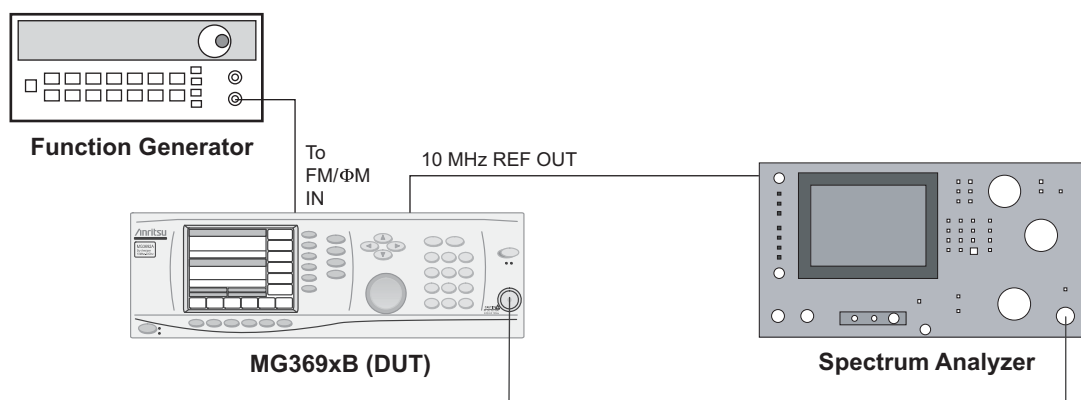

Figure 3-11. Equipment Setup for Frequency Modulation Tests

Test Setup

Connect the equipment, shown in [Figure 3-11](#), as follows:

1. Connect the MG369xB rear panel 10 MHz REF OUT to the Spectrum Analyzer's external reference input.
2. Connect the RF OUTPUT of the MG369xB to the Spectrum Analyzer's RF input.
3. Connect the Function Generator output to the MG369xB's rear panel FM/ Φ M IN connector.

Note

The Frequency Modulation test and Phase Modulation test results for many of the FM tests may be a small change. In many cases, it is preferred to set the Spectrum Analyzer to 1 dB/division.

Locked FM Accuracy

FM accuracy is verified at 5 GHz and 20 GHz in both the locked and locked low-noise modes of operation.

Locked External FM Accuracy at 5 GHz

1. Set up the test equipment as shown in [Figure 3-11](#).
2. Set up the Function Generator as follows:
 - a. Press the  key to select the sine wave function.
 - b. Press the **Freq** key and use the rotary knob to adjust the frequency output to 99.8 kHz.
 - c. Press the **Ampl** key and use the rotary knob to adjust the amplitude to 2.0 Vp-p.
3. Set up the MG369xB as follows:

- a. Reset the instrument by pressing **SYSTEM**, then **Reset**. After reset, the CW menu is displayed.
 - b. Press **Edit F1** to open the current frequency parameter for editing and set F1 to 5 GHz.
 - c. Press the **Modulation** | FM | Internal/External keys to select external FM.
 - d. Press **Edit Sensitivity** and set the sensitivity to 99.8 kHz/V.
4. Set up the Spectrum Analyzer as follows:
- a. Press the **PRESET** key to reset the instrument.
 - b. Press **AUX CTRL**.
 - c. Press **Rear Panel** soft key.
 - d. Press **10MHz** soft key and set to “EXT”.
 - e. Press the **FREQUENCY** key and enter 5 GHz.
 - f. Press the **SPAN** key and enter 10kHz.
 - g. Press the **BW** key and set the RBW to 3 kHz and the VBW to 100 Hz.
 - h. Press the **PEAK SEARCH** key.
5. Record the value on the Spectrum Analyzer as Vmodoff in the test records.
6. On the MG369xB, press **On/Off** to turn the locked FM mode on.
7. Record the value on the Spectrum Analyzer as Vmodon in the test records.
8. Using [Table 3-5, “Modulation Index Calculations” on page 3-44](#) calculate modulation index to six decimal places. Record this value in the Test Record as “mod index”.
9. Calculate the following to three decimal places and record the results into the test record as FMerror%.
- $$\text{FMerror\%} = 100\text{ABS}[\frac{(\text{mod index} \times 99800) - 99800}{99800}]$$

Locked Low-Noise External FM Accuracy at 5 GHz

10. On the MG369xB, set Locked Low-Noise External FM mode on by pressing **Mode>**, then press **Locked Low Noise**.
 11. Set up the Spectrum Analyzer as follows:
 - a. Press the **BW** key and set the RBW to 3 kHz and the VBW to 100 Hz.
 - b. Press the **PEAK SEARCH** key.
 12. Record the value on the Spectrum Analyzer as Vmodon in the test records.
 13. On the MG369xB, press **previous** then press **On/Off** to turn off the FM mode.
 14. Record the value on the Spectrum Analyzer as Vmodoff in the test records.
 15. Using [Table 3-5, “Modulation Index Calculations” on page 3-44](#) calculate modulation index to six decimal places. Record this value in the Test Record as “mod index”.
 16. Calculate the following to three decimal places and record the results into the test record as FMerror%.
- $$\text{FMerror\%} = 100\text{ABS}[\frac{(\text{mod index} \times 99800) - 99800}{99800}]$$

Locked External FM Accuracy at 20 GHz

17. Set up the MG369xB as follows:
 - a. Press **Frequency** to open the current frequency parameter for editing.
 - b. Set the frequency to 20 GHz, then to 2.3 GHz, then back to 20 GHz.
 - c. Press **Modulation**, then press **Mode>** and select **Locked**.
 - d. Press **<Previous**, ensure the locked external FM mode is off.

18. Set up the Spectrum Analyzer as follows:
 - a. Press the **FREQUENCY** key and enter 20 GHz.
 - b. Press the **BW** key and set the RBW to 3 kHz and the VBW to 30 Hz.
 - c. Press the **PEAK SEARCH** key.
19. Record the value on the Spectrum Analyzer as Vmodoff in the test records.
20. On the MG369xB, press On/Off to turn on the FM mode.
21. Record the value on the Spectrum Analyzer as Vmodon in the test records.
22. Using [Table 3-5, “Modulation Index Calculations” on page 3-44](#) calculate modulation index to six decimal places. Record this value in the Test Record as “mod index”.
23. Calculate the following to three decimal places and record the results into the test record as FMerror%.
$$\text{FMerror\%} = 100\text{ABS}[\text{((mod index} \times 99800) - 99800) / 99800]$$

Locked Low-Noise External FM Accuracy at 20 GHz

24. On the MG369xB, select Locked Low Noise.
25. Set up the Spectrum Analyzer as follows:
 - a. Press the **BW** key and set the RBW to 3 kHz and the VBW to 30 Hz.
 - b. Press the **PEAK SEARCH** key.
26. Record the value on the Spectrum Analyzer as Vmodon in the test records.
27. On the MG369xB, press previous then press On/Off to turn on the FM mode off.
28. Record the value on the Spectrum Analyzer as Vmodoff in the test records.
29. Using [Table 3-5, “Modulation Index Calculations” on page 3-44](#) calculate modulation index to six decimal places. Record this value in the Test Record as “mod index”.
30. Calculate the following to three decimal places and record the results into the test record as FMerror%.
$$\text{FMerror\%} = 100\text{ABS}[\text{((mod index} \times 99800) - 99800) / 99800]$$

Locked Internal FM Accuracy at 5 GHz (Only for instruments with Internal FM)

31. Disconnect the Function Generator from the MG369xB's rear panel FM/ Φ M IN connector.
32. Set up the MG369xB as follows:
 - a. Reset the instrument by pressing **SYSTEM**, then Reset. After reset, the CW menu is displayed.
 - b. Press Edit F1 to open the current frequency parameter for editing and set F1 to 5 GHz.
 - c. Press the **Modulation** key, then press FM.
 - d. Press Internal/External, to select the locked internal FM mode and ensure that the FM mode is off.
 - e. Press Edit Rate and set it to 99.8 kHz.
 - f. Press Edit Deviation and set it to 99.8 kHz.
33. Set up the Spectrum Analyzer as follows:
 - a. Press **FREQUENCY** and set the center frequency to 5 GHz.
 - b. Press the **BW** key and set the RBW to 3 kHz and the VBW to 100 Hz.
 - c. Press the **PEAK SEARCH** key.
34. Record the value on the Spectrum Analyzer as Vmodoff in the test records.
35. On the MG369xB, press On/Off to turn the locked internal FM mode on.
36. Record the value on the Spectrum Analyzer as Vmodon in the test records.

37. Using [Table 3-5, “Modulation Index Calculations” on page 3-44](#) calculate modulation index to six decimal places. Record this value in the Test Record as “mod index”.
38. Calculate the following to three decimal places and record the results into the test record as FMError%.
$$\text{FMError\%} = 100\text{ABS}[\text{((mod index} \times 99800) - 99800) / 99800]$$

Locked Low-Noise Internal FM Accuracy at 5 GHz (Only for instruments with Internal FM)

39. On the MG369xB, press Mode> and select Locked Low Noise, then press <Previous.
40. Set up the Spectrum Analyzer as follows:
 - a. Press the **BW** key and set the RBW to 3 kHz and the VBW to 100 Hz.
 - b. Press the **PEAK SEARCH** key.
41. Record the value on the Spectrum Analyzer as Vmodon in the test records.
42. On the MG369xB, press previous, then press On/Off to turn on the FM mode off.
43. Record the value on the Spectrum Analyzer as Vmodoff in the test records.
44. Using [Table 3-5, “Modulation Index Calculations” on page 3-44](#) calculate modulation index to six decimal places. Record this value in the Test Record as “mod index”.
45. Calculate the following to three decimal places and record the results into the test record as FMError%.
$$\text{FMError\%} = 100\text{ABS}[\text{((mod index} \times 99800) - 99800) / 99800]$$

Locked Internal FM Accuracy at 20 GHz (Only for instruments with Internal FM)

46. Set up the MG369xB as follows:
 - a. Press **Frequency** and set the frequency to 20 GHz, then 2.3 GHz, then back to 20 GHz.
 - b. Press **Modulation**, then press Mode> and select Locked.
 - c. Press <Previous, and confirm the FM mode is off.
47. Set up the Spectrum Analyzer as follows:
 - a. Press **FREQUENCY** and set the center frequency to 20 GHz.
 - b. Press the **BW** key and set the RBW to 3 kHz and the VBW to 30 Hz.
 - c. Press the **PEAK SEARCH** key.
48. Record the value on the Spectrum Analyzer as Vmodoff in the test records.
49. On the MG369xB, press On/Off to turn the locked internal FM mode on.
50. Record the value on the Spectrum Analyzer as Vmodon in the test records.
51. Using [Table 3-5, “Modulation Index Calculations” on page 3-44](#) calculate modulation index to six decimal places. Record this value in the Test Record as “mod index”.
52. Calculate the following to three decimal places and record the results into the test record as FMError%.
$$\text{FMError\%} = 100\text{ABS}[\text{((mod index} \times 99800) - 99800) / 99800]$$

Locked Low-Noise Internal FM Accuracy at 20 GHz (Only for instruments with Internal FM)

53. On the MG369xB, press Mode> and select Locked Low Noise, then press <Previous.
54. Set up the Spectrum Analyzer as follows:
 - a. Press the **BW** key and set the RBW to 3 kHz and the VBW to 30 Hz.
 - b. Press the **PEAK SEARCH** key.
55. Record the value on the Spectrum Analyzer as Vmodon in the test records.
56. On the MG369xB, press previous then press On/Off to turn on the FM mode.
57. Record the value on the Spectrum Analyzer as Vmodoff in the test records.

58. Using [Table 3-5, “Modulation Index Calculations” on page 3-44](#) calculate modulation index to six decimal places. Record this value in the Test Record as “mod index”.
59. Calculate the following to three decimal places and record the results into the test record as FMerror%.

$$\text{FMerror\%} = 100\text{ABS}[(\text{mod index} \times 99800) - 99800] / 99800]$$

ΦM Accuracy

ΦM accuracy is verified at 5 GHz and 20 GHz in unlocked wide, unlocked narrow, locked, and locked low-noise for both external and internal modes of operation.

Note The Frequency Modulation test and Phase Modulation test results for many of the FM tests may be a small change. In many cases, it is preferred to set the Spectrum Analyzer to 1 dB/division.

Wide External ΦM Accuracy at 5 GHz

1. Set up the test equipment as illustrated in [Figure 3-11 on page 3-32](#).
2. Set up the Function Generator as follows:
 - a. Press the  key to select the sine wave function.
 - b. Press the **Freq** key and use the rotary knob to adjust the frequency output to 99.8 kHz.
 - c. Press the **Ampl** key and use the rotary knob to adjust the amplitude to 2.0 Vp-p.
3. Set up the MG369xB as follows:
 - a. Reset the instrument by pressing **SYSTEM**, then **Reset**. After reset, the CW menu is displayed.
 - b. Press **Edit F1** to open the current frequency parameter for editing and set F1 to 5 GHz.
 - c. Press the **Modulation** | ΦM | Internal/External keys to select external ΦM.
 - d. Press **Mode>** and select **Wide**, then press **<Previous**.
 - e. Press **Edit Sensitivity** and set the sensitivity to 1.00 rad/V.
4. Set up the Spectrum Analyzer as follows:
 - a. Press the **PRESET** key to reset the instrument.
 - b. Press **AUX CTRL**.
 - c. Press the **Rear Panel** soft key.
 - d. Press the **10MHz** soft key and set to “EXT”.
 - e. Press the **FREQUENCY** key and enter 5 GHz.
 - f. Press the **SPAN** key and enter 10 kHz.
 - g. Press the **BW** key and set the RBW to 3 kHz and the VBW to 100 Hz.
 - h. Press the **PEAK SEARCH** key.
5. Record the value on the Spectrum Analyzer as Vmodoff in the test records.
6. On the MG369xB, press **On/Off** to turn the ΦM mode on.
7. Record the value on the Spectrum Analyzer as Vmodon in the test records.
8. Using [Table 3-5, “Modulation Index Calculations” on page 3-44](#) calculate modulation index to six decimal places. Record this value in the Test Record as “mod index”.
9. Calculate the following to three decimal places and record the results into the test record as ΦMerror%.

$$\Phi\text{Merror\%} = 100\text{ABS}[(\text{mod index} \times 99800) - 99800] / 99800]$$

Narrow External Φ M Accuracy at 5 GHz

10. On the MG369xB, press Mode> and select Narrow, then press <Previous.
11. Set up the Spectrum Analyzer as follows:
 - a. Press the **BW** key and set the RBW to 3 kHz and the VBW to 100 Hz.
 - b. Press the **PEAK SEARCH** key.
12. Record the value on the Spectrum Analyzer as Vmodon in the test records.
13. On the MG369xB, press On/Off to turn the Φ M mode off.
14. Record the value on the Spectrum Analyzer as Vmodoff in the test records.
15. Using [Table 3-5, “Modulation Index Calculations” on page 3-44](#) calculate modulation index to six decimal places. Record this value in the Test Record as “mod index”.
16. Calculate the following to three decimal places and record the results into the test record as Φ Merror%.
$$\Phi\text{Merror}\% = 100\text{ABS}[(\text{mod index} \times 99800) - 99800] / 99800]$$

Wide External Φ M Accuracy at 20 GHz

17. Set up the MG369xB as follows:
 - a. Press **Frequency** and set the frequency to 20 GHz, then 2.3 GHz, then back to 20 GHz.
 - b. Select Wide, then press <Previous.
 - c. Press Edit Sensitivity and set the external Φ M sensitivity to 1.00 rad/V.
 - d. Press On/Off to ensure the Φ M mode off.
18. Set up the Spectrum Analyzer as follows:
 - a. Press **FREQUENCY** and set the center frequency to 20 GHz.
 - b. Press the **BW** key and set the RBW to 3 kHz and the VBW to 30 Hz.
 - c. Press the **PEAK SEARCH** key.
19. Record the value on the Spectrum Analyzer as Vmodoff in the test records.
20. On the MG369xB, press On/Off to turn the Φ M mode on.
21. Record the value on the Spectrum Analyzer as Vmodon in the test records.
22. Using [Table 3-5, “Modulation Index Calculations” on page 3-44](#) calculate modulation index to six decimal places. Record this value in the Test Record as “mod index”.
23. Calculate the following to three decimal places and record the results into the test record as Φ Merror%.
$$\Phi\text{Merror}\% = 100\text{ABS}[(\text{mod index} \times 99800) - 99800] / 99800]$$

Narrow External Φ M Accuracy at 20 GHz

24. On the MG369xB, press Mode> and select Narrow, then press <Previous.
25. Set up the Spectrum Analyzer as follows:
 - a. Press the **BW** key and set the RBW to 3 kHz and the VBW to 30 Hz.
 - b. Press the **PEAK SEARCH** key.
26. Record the value on the Spectrum Analyzer as Vmodon in the test records.
27. On the MG369xB, press On/Off to turn the Φ M mode off.
28. Record the value on the Spectrum Analyzer as Vmodoff in the test records.
29. Using [Table 3-5, “Modulation Index Calculations” on page 3-44](#) calculate modulation index to six decimal places. Record this value in the Test Record as “mod index”.

30. Calculate the following to three decimal places and record the results into the test record as Φ ModError%.

$$\Phi\text{ModError}\% = 100\text{ABS}[\text{((mod index} \times 99800) - 99800) / 99800]$$

Wide Internal Φ M Accuracy 5 GHz (Only for instruments with Internal Phase Modulation)

31. Disconnect the Function Generator from the MG369xB's rear panel FM/ Φ M IN connector.

32. Set up the MG369xB as follows:

- a. Reset the instrument by pressing **SYSTEM**, then Reset. After reset, the CW menu is displayed.
- b. Press Edit F1 to open the current frequency parameter for editing and set F1 to 5 GHz.
- c. Press the **Modulation** | Φ M | Internal/External to select internal Φ M, then press On/Off to turn the locked internal Φ M mode off.
- d. Press Mode> and select Wide, then press <Previous.
- e. Press Edit Rate and set it to 99.8 kHz.
- f. Press Edit Deviation and set it to 1.00 rad.

33. Set up the Spectrum Analyzer as follows:

- a. Press **FREQUENCY** and set the center frequency to 5 GHz.
- b. Press the **BW** key and set the RBW to 3 kHz and the VBW to 100 Hz.
- c. Press the **PEAK SEARCH** key.

34. Record the value on the Spectrum Analyzer as Vmodoff in the test records.

35. On the MG369xB, press On/Off to turn the locked internal Φ M mode on.

36. Record the value on the Spectrum Analyzer as Vmodon in the test records.

37. Using [Table 3-5, "Modulation Index Calculations" on page 3-44](#) calculate modulation index to six decimal places. Record this value in the Test Record as "mod index".

38. Calculate the following to three decimal places and record the results into the test record as Φ ModError%.

$$\Phi\text{ModError}\% = 100\text{ABS}[\text{((mod index} \times 99800) - 99800) / 99800]$$

Narrow Internal Φ M Accuracy at 5 GHz (Only for instruments with Internal Phase Modulation)

39. On the MG369xB, press Mode> and select Narrow, then press <Previous.

40. Set up the Spectrum Analyzer as follows:

- a. Press the **BW** key and set the RBW to 3 kHz and the VBW to 100 Hz.
- b. Press the **PEAK SEARCH** key.

41. Record the value on the Spectrum Analyzer as Vmodon in the test records.

42. On the MG369xB, press On/Off to turn the Φ M mode off.

43. Record the value on the Spectrum Analyzer as Vmodoff in the test records.

44. Using [Table 3-5, "Modulation Index Calculations" on page 3-44](#) calculate modulation index to six decimal places. Record this value in the Test Record as "mod index".

45. Calculate the following to three decimal places and record the results into the test record as Φ ModError%.

$$\Phi\text{ModError}\% = 100\text{ABS}[\text{((mod index} \times 99800) - 99800) / 99800]$$

Wide Internal Φ M Accuracy at 20 GHz (Only for instruments with Internal Phase Modulation)

46. Set up the MG369xB as follows:

- a. Press **Frequency** and set the frequency to 20 GHz, then to 2.3 GHz, then back to 20 GHz.
- b. Press **Modulation**, then press Mode> and select Wide.

- c. Press <Previous and set the Φ M deviation to 1.00 rad/V.
 - d. Press On/Off to ensure the wide internal Φ M mode off.
47. Set up the Spectrum Analyzer as follows:
- a. Press **FREQUENCY** and set the center frequency to 20 GHz.
 - b. Press the **BW** key and set the RBW to 3 kHz and the VBW to 30 Hz.
 - c. Press the **PEAK SEARCH** key.
48. Record the value on the Spectrum Analyzer as Vmodoff in the test records.
49. On the MG369xB, press On/Off to turn the locked internal Φ M mode on.
50. Record the value on the Spectrum Analyzer as Vmodon in the test records.
51. Using [Table 3-5, “Modulation Index Calculations” on page 3-44](#) calculate modulation index to six decimal places. Record this value in the Test Record as “mod index”.
52. Calculate the following to three decimal places and record the results into the test record as Φ Merror%.
- $$\Phi\text{Merror}\% = 100\text{ABS}[\text{((mod index} \times 99800) - 99800) / 99800]$$

Narrow Internal Φ M Accuracy at 20 GHz (Only for instruments with Internal Phase Modulation)

53. On the MG369xB, press Mode> and select Narrow, then press <Previous.
54. Set up the Spectrum Analyzer as follows:
- a. Press the **BW** key and set the RBW to 3 kHz and the VBW to 30 Hz.
 - b. Press the **PEAK SEARCH** key.
55. Record the value on the Spectrum Analyzer as Vmodon in the test records.
56. On the MG369xB, press On/Off to turn the Φ M mode off.
57. Record the value on the Spectrum Analyzer as Vmodoff in the test records.
58. Using [Table 3-5, “Modulation Index Calculations” on page 3-44](#) calculate modulation index to six decimal places. Record this value in the Test Record as “mod index”.
59. Calculate the following to three decimal places and record the results into the test record as Φ Merror%.
- $$\Phi\text{Merror}\% = 100\text{ABS}[\text{((mod index} \times 99800) - 99800) / 99800]$$

FM/ΦM Flatness and Bandwidth

The FM/ΦM flatness and bandwidth tests verify that the MG369xB's modulated RF output meets specification while in the locked FM mode and in the narrow and wide ΦM modes.

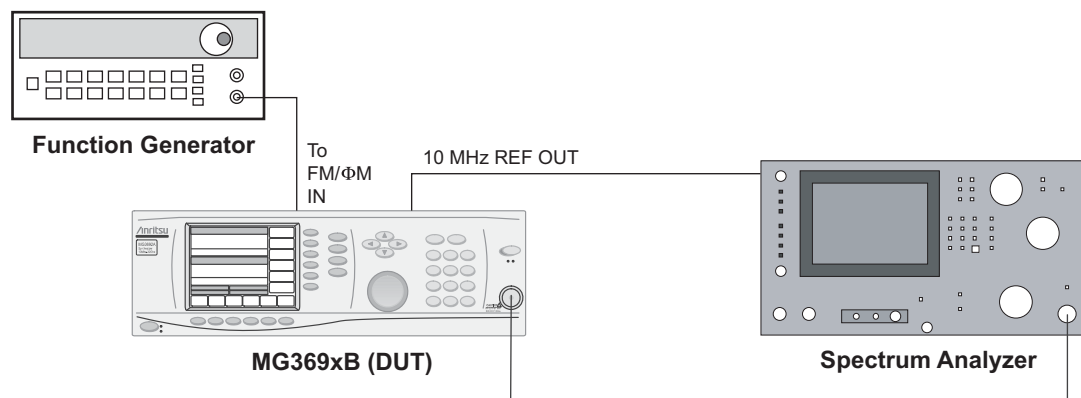

Figure 3-12. Equipment Setup for Frequency/Phase Modulation Flatness and Bandwidth Tests

Test Setup

Set up the equipment, shown in [Figure 3-12](#), as follows:

1. Connect the RF Output of the MG369xB to the RF input of the Spectrum Analyzer.
2. Connect the 10 MHz REF OUT of the MG369xB to the 10 MHz reference input of the Spectrum Analyzer.
3. Connect the Output port of the Function Generator to the FM/ΦM IN connector of the MG369xB.

Note

Since a potential spur exists at 100 kHz, which could affect accuracy, the measurement is performed with the Function Generator set to 99.8 kHz.

Locked FM Flatness

1. Connect the equipment as shown in [Figure 3-12](#).
2. Set up the MG369xB as follows:
 - a. Reset the instrument by pressing **SYSTEM**, then Reset. After reset, the CW menu is displayed.
 - b. Press Edit F1 to open the current frequency parameter for editing and set F1 to 5 GHz.
 - c. Press **Modulation** | FM | Internal/External to select external FM.
 - d. Press Edit Sensitivity and set it to 99.8 kHz/V.
3. Set up the Spectrum Analyzer as follows:
 - a. Press the **PRESET** key to reset the instrument.
 - b. Press **AUX CTRL**.
 - c. Press the Rear Panel soft key.
 - d. Press the 10MHz soft key and set to "EXT".
 - e. Press the **FREQUENCY** key and enter 5 GHz.
 - f. Press the **SPAN** key and enter 10 kHz.
 - g. Press the **AMPLITUDE** key, then press LOG dB/DIV and enter 1 dB.
 - h. Press the **BW** key and set the RBW to 3 kHz and the VBW to 10 Hz.

- i. Press **PEAK SEARCH**.
4. Set up the Function Generator as follows:
 - a. Press the \sim key to select the sine wave function.
 - b. Press the **Freq** key and use the rotary knob to adjust the frequency output to 99.8 kHz.
 - c. Press the **Ampl** key and press the green **Enter Number** key and enter 2 Vp-p.
 5. Observe the trace on the Spectrum Analyzer. It should be just below the top of the screen at about 0 dBm or lower depending on cable loss.
 6. Record the value on the Spectrum Analyzer as Vmodoff in the test records.
 7. On the MG369xB, press On/Off to turn the FM mode on. The level on the Spectrum Analyzer should fall significantly.
 8. Record the value on the Spectrum Analyzer as Vmodon in the test records.
 9. Using [Table 3-5, “Modulation Index Calculations” on page 3-44](#) calculate modulation index to six decimal places. Record this value in the Test Record as “mod index”.
 10. On the MG369xB, press On/Off to turn the FM mode off.
 11. Repeat steps 6 through 11 for each of the Function Generator frequency and MG369xB FM sensitivity pairs listed in the test record.
 12. Calculate the FM flatness by comparing each of the Vmodon values from the Vmodon value at the 100 kHz rate by calculate the following to three decimal places and record the results into the test record as FMflat.

$$\text{FMflat} = 20\log((\text{mod index @ 99.8 kHz}) / (\text{mod index @ X Hz}))$$

Narrow Φ M Flatness

1. Connect the equipment as shown in [Figure 3-12](#).
2. Set up the MG369xB as follows:
 - a. Reset the instrument by pressing **SYSTEM**, then **Reset**. After reset, the CW menu is displayed.
 - b. Press **Edit F1** to open the current frequency parameter for editing and set F1 to 5 GHz.
 - c. Press **Modulation** | Φ M | Internal/External to select external Φ M.
 - d. Press **Mode>** | **Narrow** | **<Previous** to select the narrow Φ M mode and return to the External Φ M Status menu.
 - e. Press **Edit Sensitivity** and set it to 1.00 rad/V.
3. Set up the Spectrum Analyzer as follows:
 - a. Press the **PRESET** key to reset the instrument.
 - b. Press **AUX CTRL**.
 - c. Press the Rear Panel soft key.
 - d. Press the 10MHz soft key and set it to “EXT”.
 - e. Press the **FREQUENCY** key and enter 5 GHz.
 - f. Press the **SPAN** key and enter 10 kHz.
 - g. Press the **AMPLITUDE** key then press the **LOG dB/DIV** and enter 1 dB.
 - h. Press the **BW** key and set the RBW to 3 kHz and the VBW to 10 Hz.
 - i. Press **PEAK SEARCH**.

4. Set up the Function Generator as follows:
 - a. Press the  key to select the sine wave function.
 - b. Press the **Freq** key and use the rotary knob to adjust the frequency output to 98.8 kHz.
 - c. Press the **Ampl** key and use the rotary knob to adjust the amplitude to 2.0 Vp-p.

Note Since a potential spur exists at 100 kHz, which could affect accuracy, the measurement is performed with the Function Generator set to 99.8 kHz.

5. Observe the trace on the Spectrum Analyzer. It should be just below the top of the screen at about 0 dBm or lower depending on the cable loss.
6. Record the value on the Spectrum Analyzer as Vmodoff in the test records.
7. On the MG369xB, press On/Off to turn the Φ M mode on. The level on the Spectrum Analyzer should fall significantly.
8. Record the value on the Spectrum Analyzer as Vmodon in the test records.
9. Using [Table 3-5, “Modulation Index Calculations” on page 3-44](#) calculate modulation index to six decimal places. Record this value in the Test Record as “mod index”.
10. On the MG369xB, press On/Off to turn the Φ M mode off.
11. Repeat steps 6 through 11 for each of the Function Generator frequency and MG369xB Φ M sensitivity pairs listed in the test record.
12. Calculate the Φ M flatness by comparing each of the Vmodon values from the Vmodon value at the 100 kHz rate by calculating the following to three decimal places and record the results into the test record as Φ Mflat.

$$\Phi M_{flat} = 20 \log((\text{mod index @ 99.8 kHz}) / (\text{mod index @ X Hz}))$$

Wide Φ M Flatness

1. Connect the equipment as shown in [Figure 3-12](#).
2. Set up the MG369xB as follows:
 - a. Reset the instrument by pressing **SYSTEM**, then **Reset**. After reset, the CW menu is displayed.
 - b. Press **Edit F1** to open the current frequency parameter for editing and set F1 to 5 GHz.
 - c. Press **Modulation** | Φ M | Internal/External to select external Φ M.
 - d. Press **Mode>** | Wide | <Previous to select the wide Φ M mode and return to the External Φ M Status menu.
 - e. Press **Edit Sensitivity** and set it to 1.00 rad/V.
3. Set up the Spectrum Analyzer as follows:
 - a. Press the **PRESET** key to reset the instrument.
 - b. Press **AUX CTRL**.
 - c. Press the Rear Panel soft key.
 - d. Press the 10MHz soft key and set it to “EXT”.
 - e. Press the **FREQUENCY** key and enter 5 GHz.
 - f. Press the **SPAN** key and enter 10 kHz.
 - g. Press the **AMPLITUDE** key then press LOG dB/DIV and enter 1 dB.
 - h. Press the **BW** key and set the RBW to 3 kHz and the VBW to 100 Hz.
 - i. Press **PEAK SEARCH**.

4. Set up the Function Generator as follows:
 - a. Press the  key to select the sine wave function.
 - b. Press the **Freq** key and use the rotary knob to adjust the frequency output to 99.8 kHz.
 - c. Press the **Ampl** key and use the rotary knob to adjust the amplitude to 2.0 Vp-p.

Note	Since a potential spur exists at 100 kHz, which could affect accuracy, the measurement is performed with the Function Generator set to 99.8 kHz.
-------------	--

5. Observe the trace on the Spectrum Analyzer. It should be just below the top of the screen at about 0 dBm or lower depending on the cable loss.
6. Record the value on the Spectrum Analyzer as Vmodoff in the test records.
7. On the MG369xB, press On/Off to turn the Φ M mode on. The level on the Spectrum Analyzer should fall significantly.
8. Record the value on the Spectrum Analyzer as Vmodon in the test records.
9. Using [Table 3-5, “Modulation Index Calculations” on page 3-44](#) calculate modulation index to six decimal places. Record this value in the Test Record as “mod index”.
10. On the MG369xB, press On/Off to turn the Φ M mode off.
11. Repeat steps 6 through 11 for each of the Function Generator frequency and MG369xB Φ M sensitivity pairs listed in the test record.
12. Calculate the Φ M flatness by comparing each of the Vmodon values from the Vmodon value at the 100 kHz rate by calculate the following to three decimal places and record the results into the test record as Φ Mflat.

$$\Phi\text{Mflat} = 20\log((\text{mod index @ 99.8 kHz}) / (\text{mod index @ X Hz}))$$

Modulation Index Calculations

The modulation index calculation was developed using a Taylor series and Newtons method and is used to find the root of the Bessel function. The calculation is in [Table 3-5](#).

Note [Table 3-5](#) is available as a link from the electronic version of this document as a text file ([modulation_index_calculations.txt](#)) or an excel file ([modulation_index_calculations.xls](#)). These files are also available from the Anritsu Company web site as part of the MG369xB MM PDF file.

Table 3-5. Modulation Index Calculations (Sheet 1 of 2)

Vmodon = dBm measurement of the CW with Modulation on

Vmodoff = dBm measurement of the CW with Modulation off

Constant_A= 1

RESULT_FINAL = Modulation Index

RESULT_1 =

$$\text{CONSTANT_A} - (1 - \text{CONSTANT_A}^2/4 + \text{CONSTANT_A}^4/64 - \text{CONSTANT_A}^6/2304 + \text{CONSTANT_A}^8/147456 - \text{CONSTANT_A}^{10}/14745600 - 10^{((\text{Vmodon} - \text{Vmodoff})/20)}) / (-\text{CONSTANT_A}/2 + \text{CONSTANT_A}^3/16 - \text{CONSTANT_A}^5/384 + \text{CONSTANT_A}^7/18432 - \text{CONSTANT_A}^9/1474560)$$

RESULT_2 =

$$\text{RESULT_1} - (1 - \text{RESULT_1}^2/4 + \text{RESULT_1}^4/64 - \text{RESULT_1}^6/2304 + \text{RESULT_1}^8/147456 - \text{RESULT_1}^{10}/14745600 - 10^{((\text{Vmodon} - \text{Vmodoff})/20)}) / (-\text{RESULT_1}/2 + \text{RESULT_1}^3/16 - \text{RESULT_1}^5/384 + \text{RESULT_1}^7/18432 - \text{RESULT_1}^9/1474560)$$

RESULT_3 =

$$\text{RESULT_2} - (1 - \text{RESULT_2}^2/4 + \text{RESULT_2}^4/64 - \text{RESULT_2}^6/2304 + \text{RESULT_2}^8/147456 - \text{RESULT_2}^{10}/14745600 - 10^{((\text{Vmodon} - \text{Vmodoff})/20)}) / (-\text{RESULT_2}/2 + \text{RESULT_2}^3/16 - \text{RESULT_2}^5/384 + \text{RESULT_2}^7/18432 - \text{RESULT_2}^9/1474560)$$

RESULT_4 =

$$\text{RESULT_3} - (1 - \text{RESULT_3}^2/4 + \text{RESULT_3}^4/64 - \text{RESULT_3}^6/2304 + \text{RESULT_3}^8/147456 - \text{RESULT_3}^{10}/14745600 - 10^{((\text{Vmodon} - \text{Vmodoff})/20)}) / (-\text{RESULT_3}/2 + \text{RESULT_3}^3/16 - \text{RESULT_3}^5/384 + \text{RESULT_3}^7/18432 - \text{RESULT_3}^9/1474560)$$

RESULT_5 =

$$\text{RESULT_4} - (1 - \text{RESULT_4}^2/4 + \text{RESULT_4}^4/64 - \text{RESULT_4}^6/2304 + \text{RESULT_4}^8/147456 - \text{RESULT_4}^{10}/14745600 - 10^{((\text{Vmodon} - \text{Vmodoff})/20)}) / (-\text{RESULT_4}/2 + \text{RESULT_4}^3/16 - \text{RESULT_4}^5/384 + \text{RESULT_4}^7/18432 - \text{RESULT_4}^9/1474560)$$

RESULT_6 =

$$\text{RESULT_5} - (1 - \text{RESULT_5}^2/4 + \text{RESULT_5}^4/64 - \text{RESULT_5}^6/2304 + \text{RESULT_5}^8/147456 - \text{RESULT_5}^{10}/14745600 - 10^{((\text{Vmodon} - \text{Vmodoff})/20)}) / (-\text{RESULT_5}/2 + \text{RESULT_5}^3/16 - \text{RESULT_5}^5/384 + \text{RESULT_5}^7/18432 - \text{RESULT_5}^9/1474560)$$

RESULT_7 =

$$\text{RESULT_6} - (1 - \text{RESULT_6}^2/4 + \text{RESULT_6}^4/64 - \text{RESULT_6}^6/2304 + \text{RESULT_6}^8/147456 - \text{RESULT_6}^{10}/14745600 - 10^{((\text{Vmodon} - \text{Vmodoff})/20)}) / (-\text{RESULT_6}/2 + \text{RESULT_6}^3/16 - \text{RESULT_6}^5/384 + \text{RESULT_6}^7/18432 - \text{RESULT_6}^9/1474560)$$

RESULT_8 =

$$\text{RESULT_7} - (1 - \text{RESULT_7}^2/4 + \text{RESULT_7}^4/64 - \text{RESULT_7}^6/2304 + \text{RESULT_7}^8/147456 - \text{RESULT_7}^{10}/14745600 - 10^{((\text{Vmodon} - \text{Vmodoff})/20)}) / (-\text{RESULT_7}/2 + \text{RESULT_7}^3/16 - \text{RESULT_7}^5/384 + \text{RESULT_7}^7/18432 - \text{RESULT_7}^9/1474560)$$

RESULT_9 =

$$\text{RESULT_8} - (1 - \text{RESULT_8}^2/4 + \text{RESULT_8}^4/64 - \text{RESULT_8}^6/2304 + \text{RESULT_8}^8/147456 - \text{RESULT_8}^{10}/14745600 - 10^{((\text{Vmodon} - \text{Vmodoff})/20)}) / (-\text{RESULT_8}/2 + \text{RESULT_8}^3/16 - \text{RESULT_8}^5/384 + \text{RESULT_8}^7/18432 - \text{RESULT_8}^9/1474560)$$

Table 3-5. Modulation Index Calculations (Sheet 2 of 2)

RESULT_10 =

$$\text{RESULT_9} - \frac{(1 - \text{RESULT_9}^2/4 + \text{RESULT_9}^4/64 - \text{RESULT_9}^6/2304 + \text{RESULT_9}^8/147456 - \text{RESULT_9}^{10}/14745600 - 10^{((V_{\text{modon}} - V_{\text{modoff}})/20)})}{(-\text{RESULT_9}/2 + \text{RESULT_9}^3/16 - \text{RESULT_9}^5/384 + \text{RESULT_9}^7/18432 - \text{RESULT_9}^9/1474560)}$$

RESULT_11 =

$$\text{RESULT_10} - \frac{(1 - \text{RESULT_10}^2/4 + \text{RESULT_10}^4/64 - \text{RESULT_10}^6/2304 + \text{RESULT_10}^8/147456 - \text{RESULT_10}^{10}/14745600 - 10^{((V_{\text{modon}} - V_{\text{modoff}})/20)})}{(-\text{RESULT_10}/2 + \text{RESULT_10}^3/16 - \text{RESULT_10}^5/384 + \text{RESULT_10}^7/18432 - \text{RESULT_10}^9/1474560)}$$

RESULT_12 =

$$\text{RESULT_11} - \frac{(1 - \text{RESULT_11}^2/4 + \text{RESULT_11}^4/64 - \text{RESULT_11}^6/2304 + \text{RESULT_11}^8/147456 - \text{RESULT_11}^{10}/14745600 - 10^{((V_{\text{modon}} - V_{\text{modoff}})/20)})}{(-\text{RESULT_11}/2 + \text{RESULT_11}^3/16 - \text{RESULT_11}^5/384 + \text{RESULT_11}^7/18432 - \text{RESULT_11}^9/1474560)}$$

RESULT_13 =

$$\text{RESULT_12} - \frac{(1 - \text{RESULT_12}^2/4 + \text{RESULT_12}^4/64 - \text{RESULT_12}^6/2304 + \text{RESULT_12}^8/147456 - \text{RESULT_12}^{10}/14745600 - 10^{((V_{\text{modon}} - V_{\text{modoff}})/20)})}{(-\text{RESULT_12}/2 + \text{RESULT_12}^3/16 - \text{RESULT_12}^5/384 + \text{RESULT_12}^7/18432 - \text{RESULT_12}^9/1474560)}$$

RESULT_FINAL =

$$\text{RESULT_13} - \frac{(1 - \text{RESULT_13}^2/4 + \text{RESULT_13}^4/64 - \text{RESULT_13}^6/2304 + \text{RESULT_13}^8/147456 - \text{RESULT_13}^{10}/14745600 - 10^{((V_{\text{modon}} - V_{\text{modoff}})/20)})}{(-\text{RESULT_13}/2 + \text{RESULT_13}^3/16 - \text{RESULT_13}^5/384 + \text{RESULT_13}^7/18432 - \text{RESULT_13}^9/1474560)}$$

Unlocked Narrow FM Accuracy

The unlocked narrow FM accuracy procedure measures the FM accuracy in unlocked narrow FM mode.

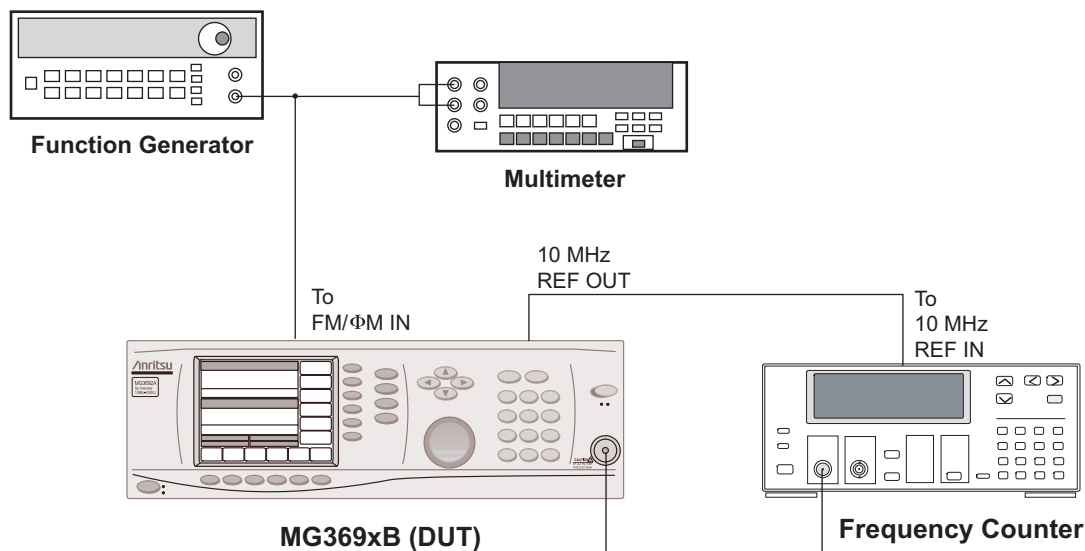

Figure 3-13. Equipment Setup for FM Accuracy Test in Unlocked Narrow Mode

Test Setup

Set up the equipment, shown in [Figure 3-13](#), as follows:

1. Connect the RF Output of the MG369xB to Input 1 of the frequency counter.
2. Connect the 10 MHz REF OUT of the MG369xB to the 10 MHz reference input of the frequency counter.
3. Using a BNC tee, connect the output port of the Function Generator to the input of the multimeter and to the Φ M/FM IN connector of the MG369xB.
4. On frequency counter press **Preset**. Verify that the key parameters are set as follows:

Measurement mode: CW / CW

Resolution: 100 Hz / 100 Hz

Sample rate: 100 ms / 100 ms

Gate width value: 100 ms / 100 ms

Gate end: Off / Off

Test Procedure

The following procedure lets you verify the external FM accuracy of the MG369xB's RF output.

1. Set up the MG369xB as follows:
 - a. Reset the instrument by pressing **SYSTEM**, then **Reset**. After reset, the CW menu is displayed.
 - b. Press **Edit F1** to open the current frequency parameter for editing and set F1 to 5.0 GHz.
 - c. Press **Modulation** | **FM** | **Internal/External** to select external FM.

- d. Set the FM mode to unlocked narrow by pressing **Mode> | Unlocked Narrow**, then press **<Previous** to return to the **External FM Status** menu.
 - e. Set the sensitivity to 10 MHz/V by pressing **Edit Sensitivity** and enter 10 MHz.
 - f. Turn the external FM mode on by pressing **On/Off**.
2. Set up the Function Generator as follows:
 - a. Power cycle the function generator to ensure it is in the default state (1 kHz sine wave, 100 mV peak-to-peak, 50 ohm termination).
 - b. Press the **OFFSET** key and hold it down for more than 2 seconds. This action will put the Function Generator into VDC mode.
 - c. Rotate the knob to adjust the value until +1V DC is measured on the multimeter.
 3. Disconnect the +1V DC signal from the MG369xB's FM/ΦM IN connector.
 4. Record the frequency counter's displayed frequency to the fourth decimal place (for example, 4.9982 GHz) in the test record as FMref.
 5. Reconnect the +1V DC signal to the MG369xB's FM/ΦM IN connector.
 6. Record the frequency counter's displayed frequency to the fourth decimal place (for example, 5.0082 GHz) in the test record as FMmod.
 7. Calculate the FM accuracy error (FMerr) and record the result in the test record as follows:

$$FM_{err} = \left[1 - \left(\frac{FM_{mod} - FM_{ref}}{0.010} \right) \right] \times 100$$

3-11 Amplitude Modulation Tests

This procedure verifies the operation of the MG369xB amplitude modulation input sensitivity circuits. The modulated RF output of the MG369xB is down converted and the (modulated) IF is then measured with a modulation analyzer. The actual modulation values are then computed from the modulation analyzer readings. (The absolute AM PK+ and AM PK- readings are used in the given procedures to compensate for non-linearity errors in the test equipment.)

Note Before performing this procedure ensure that all test equipment is calibrated. Refer to the manufacturer's test equipment manual.

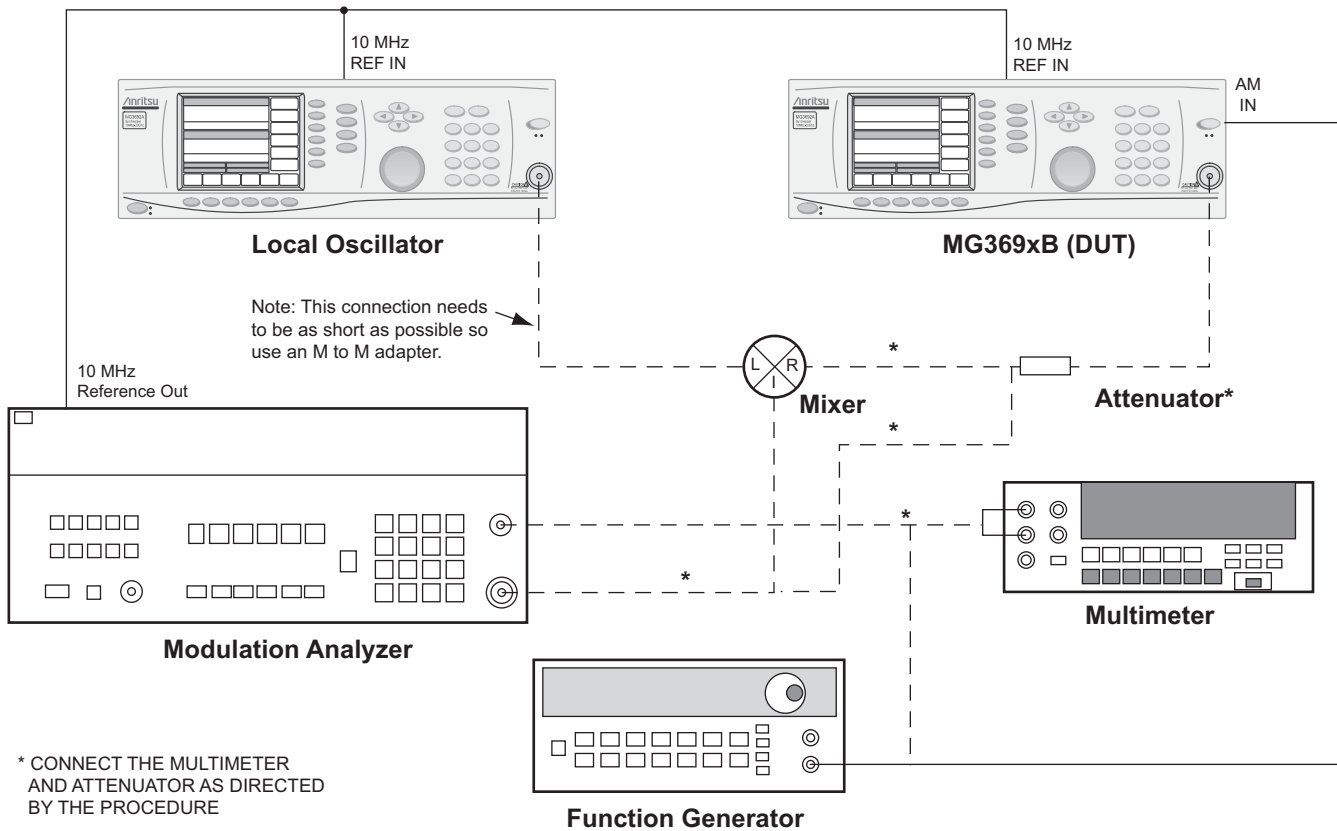

Figure 3-14. Equipment Setup for Amplitude Modulation Tests

Test Setup

Connect the equipment, shown in [Figure 3-14](#), as follows:

1. Using a BNC tee, connect the rear panel 10 MHz reference output of the modulation analyzer to the MG369xB's and local oscillator's 10 MHz REF IN connectors.
2. Connect the RF output of the MG369xB to the modulation analyzer's RF input.
3. Using a BNC tee, connect the Function Generator output to the AM IN connector of the MG369xB and to the multimeter input.

External AM Accuracy

The following procedure lets you measure the absolute peak external AM values for a 50% AM signal at 6 dB below maximum rated output power and calculate the modulation index.

1. Set up the MG369xB as follows:
 - a. Reset the instrument by pressing **SYSTEM**, then **Reset**. After reset, the CW menu is displayed.
 - b. Press **Edit F1** to open the current frequency parameter for editing.
 - c. Set **F1** to the first/next applicable DUT frequency listed in the test record.
 - d. Press **Edit L1** to open the current level parameter for editing.
 - e. Set **L1** to 6 dB below the maximum rated leveled power for the full band (lowest of the maximum rated power levels) for the instrument being tested (refer to Appendix B, Technical Data Sheet). Specifications).
 - f. Press **Modulation**, **AM**, then **Internal/External** to select external AM, then set on/off to on.
 - g. Press **Log/Linear** to select linear modulation.
 - h. Press **Edit Sensitivity** and set the AM sensitivity to 50%.
2. Connect attenuation PAD to the DUT RF output for the following output power conditions:
 - $L1 < 0$ dBm, install a 6 dB attenuation PAD
 - $0 \text{ dBm} < L1 \leq 3$ dBm, install a 10 dB attenuation PAD
 - $3 \text{ dBm} < L1 \leq 13$ dBm, install a 20 dB attenuation PAD
 - $13 \text{ dBm} < L1 \leq 20$ dBm, install a 26 dB attenuation PAD
3. Set up the local oscillator as follows (the local oscillator is not required on the first frequency measured):
 - a. Reset the instrument by pressing **System**, then **Reset**. After reset, the CW menu is displayed.
 - b. Press **Edit F1** to open the current frequency parameter for editing.
 - c. Set **F1** to the first/next applicable LO frequency listed in the test record.
 - d. Press **Edit L1** to open the current level parameter for editing and set **L1** to +6 dBm.
4. Set the multimeter to measure an AC signal by pressing **V AC**, then **Auto**.
5. Set up the Function Generator as follows:
 - a. Press the  (sine wave) key, then the **Freq** key and adjust the frequency to 1 kHz using the rotary knob.
 - b. Press the **Ampl** key and adjust the voltage to $0.7071 V_{\text{rms}}$ using the rotary knob (read the voltage on the multimeter).
6. Set up the modulation analyzer as follows:
 - a. Press the **HP Filter 300 Hz** key to set the high pass filter to 300 Hz.
 - b. Press the **LP Filter 15 kHz** key to set the low pass filter to 15 kHz.
 - c. Press **AM**, **PK+**, then **PEAK HOLD** to obtain a positive peak AM reading (Pk1).
 - d. Press **AM**, **PK-**, then **PEAK HOLD** to obtain a negative peak AM reading (Pk2).
7. Calculate the modulation index (M) from the above values as follows:

$$M = \frac{\text{Pk1} + \text{Pk2}}{200 + \text{Pk1} - \text{Pk2}} \times 100$$
8. Record the calculated result as M in the test record.
9. Connect the RF output of the local oscillator and the MG369xB to the mixer's L- and R-ports, respectively, then connect the IF output of the mixer to the modulation analyzer's RF input.

10. Repeat the measurement for each of the local oscillator and MG369xB CW frequency pairs listed in the test record.

Internal AM Accuracy

The following procedure (for instruments with internal AM only) lets you measure the absolute peak internal AM values for a 50% AM signal at 6 dB below maximum rated output power and calculate the modulation index.

Test Setup

Connect the equipment, shown in [Figure 3-14](#), as follows:

1. Using a BNC tee, connect the rear panel 10 MHz reference output of the modulation analyzer to the MG369xB's and local oscillator's 10 MHz REF IN connectors.
2. Connect the RF output of the MG369xB to the modulation analyzer's RF input.
3. Using a BNC tee, connect the Function Generator output to the AM IN connector of the MG369xB and to the multimeter input.

Test Procedure

1. Set up the MG369xB as follows:
 - a. Reset the instrument by pressing **SYSTEM**, then **Reset**. After reset, the CW menu is displayed.
 - b. Press **Edit F1** to open the current frequency parameter for editing.
 - c. Set F1 to the first/next applicable frequency in the test record.
2. Connect an attenuation PAD to the DUT RF output for the following output power conditions:
 - $L1 < 0$ dBm, install a 6 dB attenuation PAD
 - 0 dBm $< L1 \leq 3$ dBm, install a 10 dB attenuation PAD
 - 3 dBm $< L1 \leq 13$ dBm, install a 20 dB attenuation PAD
 - 13 dBm $< L1 \leq 20$ dBm, install a 26 dB attenuation PAD
3. Set up the MG369xB as follows:
 - a. Press **Edit L1** to open the current level parameter for editing.
 - b. Set L1 to 6 dB below the maximum rated leveled power for the full band (lowest of the maximum rated power levels) for the instrument being tested (refer to Appendix B, Technical Data Sheet).
 - c. Press **Modulation**, AM, then Internal/External to select internal AM, then set on/off to on.
 - d. Press **Log/Linear** to select linear modulation.
 - e. Press **Edit Depth** and set the AM depth to 50%.
 - f. Press **Edit Rate** and set the AM rate to 1 kHz.
4. Set up the local oscillator as follows (the local oscillator is not required on the first frequency measured):
 - a. Reset the instrument by pressing **System**, then **Reset**. After reset, the CW menu is displayed.
 - b. Press **Edit F1** to open the current frequency parameter for editing.
 - c. Set F1 to the first/next applicable LO frequency listed in the test record.
 - d. Press **Edit L1** to open the current level parameter for editing and set L1 to +6 dBm.
5. Disconnect the Function Generator from the MG369xB's AM IN connector.
6. Set up the modulation analyzer as follows:
 - a. Press the **HP Filter 300 Hz** key to set the high pass filter to 300 Hz.
 - b. Press the **LP Filter 15 kHz** key to set the low pass filter to 15 kHz.
 - c. Press **AM, PK+**, then **PEAK HOLD** to obtain a positive peak AM reading (Pk1).

d. Press AM, PK–, then PEAK HOLD to obtain a negative peak AM reading (Pk2).

7. Calculate the modulation index (M) from the above values as follows:

$$M = \frac{Pk1 + Pk2}{200 + Pk1 - Pk2} \times 100$$

8. Record the calculated result as M in the test record.

9. Connect the RF output of the local oscillator and the MG369xB to the mixer's L- and R-ports, respectively, then connect the IF output of the mixer to the modulation analyzer's RF input.

10. Repeat the measurement for each of the local oscillator and MG369xB CW frequency pairs listed in the test record.

AM Roll Off

The following procedure lets you measure the AM roll off of the external AM signal at 6 dB below maximum rated output power.

Test Setup

Connect the equipment, shown in [Figure 3-14](#), as follows:

1. Using a BNC tee, connect the rear panel 10 MHz reference output of the modulation analyzer to the MG369xB's and local oscillator's 10 MHz REF IN connectors.
2. Connect the RF output of the MG369xB to the modulation analyzer's RF input.
3. Using a BNC tee, connect the Function Generator output to the AM IN connector of the MG369xB and to the multimeter input.
4. Setup for the modulation Analyzer:
 - a. Turn off all HP filters.
 - b. Turn off all LP filters.

Test Procedure

1. Set up the MG369xB as follows:
 - a. Reset the instrument by pressing **SYSTEM**, then **Reset**. After reset, the CW menu is displayed.
 - b. Press **Edit F1** to open the current frequency parameter for editing.
 - c. Set **F1** to the first/next applicable DUT frequency listed in the test record.
2. Connect attenuation PAD to the DUT RF output for the following output power conditions:
 - $L1 < 0$ dBm, install a 6 dB attenuation PAD
 - $0 \text{ dBm} < L1 \leq 3$ dBm, install a 10 dB attenuation PAD
 - $3 \text{ dBm} < L1 \leq 13$ dBm, install a 20 dB attenuation PAD
 - $13 \text{ dBm} < L1 \leq 20$ dBm, install a 26 dB attenuation PAD
3. Set up the MG369xB as follows:
 - a. Press **Edit L1** to open the current level parameter for editing.
 - b. Set **L1** to 6 dB below the maximum rated leveled power for the full band (lowest of the maximum rated power levels) for the instrument being tested (refer to Appendix B, Technical Data Sheet).
 - c. Press **Modulation**, **AM**, then **Internal/External** to select external AM, then set **on/off** to **on**.
 - d. Press **Log/Linear** to select linear modulation.
 - e. Press **Edit Sensitivity** and set the AM sensitivity to 50%.

4. Set up the local oscillator as follows (the local oscillator is not required on the first frequency measured):
 - a. Reset the instrument by pressing **System**, then **Reset**. After reset, the CW menu is displayed.
 - b. Press **Edit F1** to open the current frequency parameter for editing.
 - c. Set F1 to the first/next applicable LO frequency listed in the test record.
 - d. Press **Edit L1** to open the current level parameter for editing and set L1 to +6 dBm.
5. Set the multimeter to measure an AC signal by pressing **V AC**, then **Auto**.
6. Set up the Function Generator as follows:
 - a. Press the  (sine wave) key, then the **Freq** key and adjust the frequency to 1 kHz using the rotary knob.
 - b. Press the **Ampl** key and adjust the voltage to $0.7071 V_{\text{rms}}$ with the rotary knob (read the voltage on the multimeter).
7. Disconnect the Multimeter. Then connect the multimeter to the modulation analyzer's demodulated output port and press **AM** on the modulation analyzer.
8. Record the multimeter's AC voltage value as V_1 in the test record.
9. Set the Function Generator to 50 kHz and record the multimeter's AC voltage value as V_{50} in the test record.
10. Calculate the AM roll off and record the result in the test record as AMro using the following equation:
$$AM_{ro} = 20 \times \log\left(\frac{V_{50}}{V_1}\right)$$
11. Disconnect the multimeter. Using a BNC tee, connect the Function Generator output to the AM IN connector of the MG369xB and to the multimeter input.
12. Connect the RF output of the local oscillator and the MG369xB to the mixer's L- and R-ports, respectively, then connect the IF output of the mixer to the modulation analyzer's RF input.
13. Repeat steps 5 through 12 for each of the MG369xB and local oscillator CW frequency pairs listed in the test record.

AM Flatness

The following procedure lets you measure the AM flatness of the external AM signal at 6 dB below maximum rated output power from 10 Hz to 10 kHz rates.

Test Setup

Connect the equipment, shown in [Figure 3-14](#), as follows:

1. Using a BNC tee, connect the rear panel 10 MHz reference output of the modulation analyzer to the MG369xB's and local oscillator's 10 MHz REF IN connectors.
2. Connect the RF output of the MG369xB to the modulation analyzer's RF input.
3. Using a BNC tee, connect the Function Generator output to the AM IN connector of the MG369xB and to the multimeter input.

Test Procedure

1. Set up the MG369xB as follows:
 - a. Reset the instrument by pressing **SYSTEM**, then **Reset**. After reset, the CW menu is displayed.
 - b. Press **Edit F1** to open the current frequency parameter for editing.
 - c. Set **F1** to the first/next applicable DUT frequency listed in the test record.
2. Connect attenuation PAD to the DUT RF output for the following output power conditions:
 - $L1 < 0$ dBm, install a 6 dB attenuation PAD
 - 0 dBm $< L1 \leq 3$ dBm, install a 10 dB attenuation PAD
 - 3 dBm $< L1 \leq 13$ dBm, install a 20 dB attenuation PAD
 - 13 dBm $< L1 \leq 20$ dBm, install a 26 dB attenuation PAD
3. Set up the MG369xB as follows:
 - a. Press **Edit L1** to open the current level parameter for editing.
 - b. Set **L1** to 6 dB below the maximum rated leveled power for the full band (lowest of the maximum rated power levels) for the instrument being tested (refer to Appendix B, Technical Data Sheet).
 - c. Press **Modulation**, **AM**, then **Internal/External** to select external AM, then set on/off to on.
 - d. Press **Log/Linear** to select linear modulation.
 - e. Press **Edit Sensitivity** and set the AM sensitivity to 50%.
4. Set up the local oscillator as follows (the local oscillator is not required on the first frequency measured):
 - a. Reset the instrument by pressing **System**, then **Reset**. After reset, the CW menu is displayed.
 - b. Press **Edit F1** to open the current frequency parameter for editing.
 - c. Set **F1** to the first/next applicable LO frequency listed in the test record.
 - d. Press **Edit L1** to open the current level parameter for editing and set **L1** to +6 dBm.
5. Set up the multimeter to measure an AC signal by pressing **V AC**, then **Auto**.
6. Set up the Function Generator as follows:
 - a. Press the  (sine wave) key, then the **Freq** key and adjust the frequency to 10 Hz using the rotary knob.
 - b. Press the **Ampl** key and adjust the voltage to $0.7071 V_{\text{rms}}$ using the rotary knob (read the voltage on the multimeter).
7. Disconnect the Multimeter. Connect the multimeter to the modulation analyzer's demodulated output port and press **AM** on the modulation analyzer.
8. Record the measured AC voltage value on the multimeter as V_0 in the test record.

9. Disconnect the multimeter. Using a BNC tee, connect the Function Generator output to the AM IN connector of the MG369xB and to the multimeter input.
10. Repeat steps 6 through 9 for each of the following Function Generator frequencies and record the results in the respective column in the test record:

$$V_1 = 1 \text{ kHz}$$

$$V_2 = 2 \text{ kHz}$$

$$V_3 = 3 \text{ kHz}$$

$$V_4 = 4 \text{ kHz}$$

$$V_5 = 5 \text{ kHz}$$

$$V_6 = 6 \text{ kHz}$$

$$V_7 = 7 \text{ kHz}$$

$$V_8 = 8 \text{ kHz}$$

$$V_9 = 9 \text{ kHz}$$

$$V_{10} = 10 \text{ kHz}$$

11. Find the maximum (V_{\max}) and minimum (V_{\min}) voltage values for V_x and calculate the AM flatness (AM_{flat}) using the following equation:

$$AM_{\text{flat}} = 20 \times \log\left(\frac{V_{\max}}{V_{\min}}\right)$$

12. Connect the RF output of the local oscillator and the MG369xB to the mixer's L- and R-ports, respectively, then connect the IF output of the mixer to the modulation analyzer's RF input.
13. Repeat steps 5 through 12 for each of the MG369xB and local oscillator CW frequency pairs listed in the test record.

3-12 Pulse Modulation Tests

The pulse modulation tests verify the operation of the pulse modulation circuits in the MG369xB. Rise time, fall time, overshoot, and power accuracy of the pulsed RF output are verified using a high speed digital sampling oscilloscope. Pulse depth (on/off ratio) is measured using a Spectrum Analyzer.

Note

Before performing this procedure ensure that all test equipment is calibrated. Refer to the manufacturer's test equipment manual.

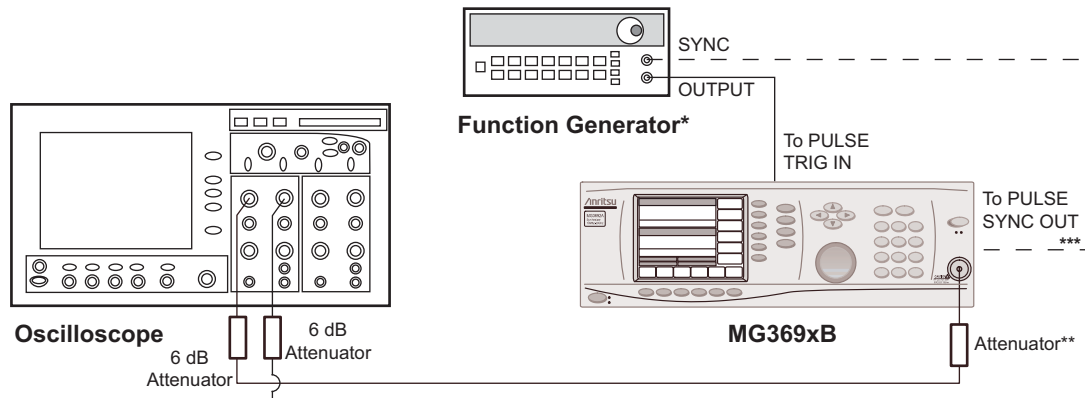

* The function generator is only required if the MG369xB does not have Options 24 or 27.

** Connect the attenuator as specified in the procedure.



*** Connect the PULSE SYNC OUT from the MG369xB or the SYNC from the function generator as appropriate.

Figure 3-15. Equipment Setup for the Pulse Modulation Tests

Test Setup

Connect the equipment shown in [Figure 3-15](#), as follows:

1. Using the 2.4 mm (f) to K (f) adapters, connect a 6 dB fixed attenuator to the oscilloscope's Channel 1 and Trigger inputs.
2. Connect a RF coaxial cable to the 6 dB attenuator at the oscilloscope's Channel 1 input.
3. For models without internal pulse, use a BNC to SMA adapter to connect a 50Ω BNC cable from the Function Generator's SYNC to the 6 dB attenuator at the oscilloscope's Trigger input.
4. For models with internal pulse, use a BNC to SMA adapter to connect a 50Ω BNC cable from the MG369xB's PULSE SYNC OUT to the 6 dB attenuator at the oscilloscope's Trigger input.
5. For models without internal pulse, connect a 50Ω BNC cable from the Function Generator's signal output to the MG369xB's rear panel PULSE TRIG IN connector.
6. Set up the oscilloscope as follows:
 - a. Press the **Default Setup** key.
 - b. From the title bar, select:
Measure | Math | Function 1
 - c. Set the operator to MAX and turn on the Function 1 display.
 - d. Select Close to close the open window.
 - e. Select the **Trigger Level** button on the bottom of the display.
 - f. Set the trigger level to 500 mV.

- g. Set the bandwidth to DC to 2.5 GHz.
 - h. Select rising edge () triggering.
 - i. Select the left module as the source.
 - j. Select **Close** to close the open window.
 - k. Turn off channel 1 on the oscilloscope by pressing the 1 key above the module (LED off).
7. For models without internal pulse, set up the Function Generator as follows:
- a. Turn the Function Generator off, then back on to reset the instrument.
 - b. Press the  key to select the square wave function.
 - c. Press the **Freq** key, then the green **Enter Number** key and enter 250 kHz.
 - d. Press the blue **Shift** key, then the %Duty Cycle key and use the rotary knob to adjust the duty cycle to 25%.
 - e. Press the **Ampl** key, then the green **Enter Number** key and enter 2.2 V_{p-p}.
 - f. Press the **Offset** key, then the green **Enter Number** key and enter 1.1 VDC.

Pulse Rise Time, Fall Time and Overshoot

The following procedure lets you measure the rise time, fall time, and overshoot of the MG369xB's pulse modulated RF output.

Repeat the measurements of the pulse rise time, pulse fall time, and pulse overshoot based on the DUT frequencies in test records.

Pulse Rise Time

1. Set up the MG369xB as follows:
 - a. Reset the instrument by pressing **SYSTEM**, then **Reset**. After reset, the CW menu is displayed.
 - b. Turn RF output off.
 - c. Press **Edit F1** to open the current frequency parameter for editing.
 - d. Press the **Frequency** button and set F1 to the first/next applicable frequency in the test record.
 - e. Press **Level** to open the current power level parameter for editing.
 - f. Set L1 to the maximum specified leveled output power level for the frequency and instrument being tested (refer to Appendix B, Technical Data Sheet).
 - g. Connect a fixed attenuator with the proper attenuation value (refer to [Table 3-6](#)) to the MG369xB RF Output, then connect the RF coaxial cable from the Channel 1 input of the oscilloscope to the fixed attenuator.

Table 3-6. MG369xB Attenuation

MG369xB Rated Power	Required Attenuation
≥18 dBm	20 dB
≥13 dBm	10 dB
≥10 dBm	6 dB
≥8 dBm	3 dB
<8 dBm	0 dB

- h. Turn RF output ON.

- i. For models *without* internal pulse:
 - (1) Press **Modulation | Pulse | Internal/External** to select the External Pulse Status menu.
 - (2) Ensure that the polarity is set to High RF On.
 - (3) Press On/Off to turn the external pulse on.

For models *with* internal pulse:

- (1) Press **Modulation | Pulse | Internal/External** to select the Internal Pulse Status menu.
- (2) Press Edit Period and enter 4 μ s.
- (3) Press Wdth/Dly List... | Edit Selected and enter 1 μ s.
- (4) Press Previous, then On/Off to turn the internal pulse mode on.

2. Set up the oscilloscope as follows:
 - a. Select the **Time/Delay** button on the bottom of the display.
 - b. Set the sweep time to 10 ns/div and the delay to 4 μ s. Select **Close** to close the window.
 - c. Press the **Clear Display** key. Allow the oscilloscope to sample the signal and wait for a clearly defined waveform to appear on the display.
 - d. Select the **Scale** button at the lower left corner of the display.
 - e. Set the scale and offset voltages so that the positive peak of the pulse is centered and the amplitude is optimally displayed. Select **Close** to close the window.
 - f. Select the **Rise Time** button (on the left hand side of the display).
3. Read the measured result from the bottom of the display and enter the result in the test record.

Pulse Fall Time

4. Set up the oscilloscope as follows:
 - a. Select the **Time/Delay** button on the bottom of the display.
 - b. Set the delay time to 5 μ s. Select **Close** to close the window.
 - c. Press the **Clear Display** key. Allow the oscilloscope to sample the signal and wait for a clearly defined waveform to appear on the display.
 - d. Select the **Fall Time** button (on the left hand side of the display).
5. Read the measured result from the bottom of the display and enter the result in the test record.

Overshoot

6. Set up the oscilloscope as follows:
 - a. Select the **Time/Delay** button on the bottom of the display.
 - b. Set the sweep time to 120 ns/div and the delay to 4 μ s. Select **Close** to close the window.
 - c. Press the **Clear Display** key. Allow the oscilloscope to sample the signal and wait for a clearly defined waveform to appear on the display.
 - d. Select the **Amplitude** button, then the **Overshoot** button (on the left hand side of the display).
7. Read the measured result from the bottom of the display and enter the result in the test record.
8. Repeat steps 1b through 7 for each frequency listed in the test record.

Pulse Power Accuracy

The following procedure lets you measure the pulse power accuracy of the MG369xB's pulse modulated RF Output. The accuracy is tested with a 1 μ s and a 0.5 μ s pulse width.

1. Disconnect the MG369xB's RF coaxial cable from the front of the unit. Set up the equipment as described in [Figure 3-15](#). Perform steps 1 to 6 in "Test Setup" on page 3-55.
2. For models without internal pulse, set up the Function Generator as follows:
 - a. Turn the Function Generator off, then back on to reset the instrument.
 - b. Press the \square key to select the square wave function.
 - c. Press the **Freq** key, then the green **Enter Number** key and enter 250 kHz.
 - d. Press the blue **Shift** key, then the **%Duty Cycle** key and use the rotary knob to adjust the duty cycle to 25%.
 - e. Press the **Ampl** key, then the green **Enter Number** key and enter 2.2 V_{p-p}.
 - f. Press the **Offset** key, then the green **Enter Number** key and enter 1.1 VDC.
3. Set up the MG369xB as follows:
 - a. Reset the instrument by pressing **SYSTEM**, then Reset. After reset, the CW menu is displayed.
 - b. Turn RF output OFF.
 - c. Press **Edit F1** to open the current frequency parameter for editing.
 - d. Set F1 to the first/next applicable frequency in the test record.
 - e. Press **Level** to open the current power level parameter for editing.
 - f. Set L1 to the maximum specified leveled output power level for the instrument being tested (refer to Appendix B, Technical Data Sheet).
 - g. Connect a fixed attenuator with the proper attenuation value (refer to [Table 3-7](#)) to the MG369xB RF Output and then connect the RF coaxial cable from the Channel 1 Input of the Oscilloscope to the fixed attenuator.

Table 3-7. MG369xB Attenuation

MG369xB Rated Power	Required Attenuation
≥ 18 dBm	20 dB
≥ 13 dBm	10 dB
≥ 10 dBm	6 dB
≥ 8 dBm	3 dB
< 8 dBm	0 dB

- h. Turn RF output ON.
- i. For models *without* internal pulse:
 - i. Press **Modulation** | Pulse | Internal/External to select the External Pulse Status menu.
 - ii. Ensure that the polarity is set to High RF Off.
 - iii. Press On/Off to turn the external pulse off.

For models *with* internal pulse:

- i. Press **Modulation** | Pulse | Internal/External to select the Internal Pulse Status menu.
- ii. Press **Edit Period** and enter 4 μ s.
- iii. Press **Wdth/Dly List...** | **Edit Selected** and enter 1 μ s (or 0.5 μ s).
- iv. Press **Previous**, then On/Off to turn the internal pulse mode off.

4. Set up the oscilloscope as follows:
 - a. Press the **Source** button (near the trigger) until Free Run is illuminated.
 - b. Select the **Scale** button at the lower left corner of the display and set the scale to 20 mV/div.
 - c. Set the **Offset** so that the trace is centered on the display, and select **Close**.
 - d. Select the **Amplitude** button and then the **Vavg** button (on the left hand side of the display), touch OK to close.

Note Use the scroll bar to locate the Vavg button.

5. Read the measured result on the display and record the result as V_{ref} in the test record.
6. On the MG369xB, press **On/Off** to turn pulse modulation on and press the **Source** button (near the trigger) until **Left Module** is illuminated.
7. Set up the oscilloscope as follows:
 - a. Press the **Clear** display key. Allow the oscilloscope to sample the signal and wait for a clearly defined waveform to appear on the display.
 - b. Select **Time Delay** and scale so that only the positive peak portion of the pulse fills the display (for example, set the scale to 90 ns/div and the delay time to 4.075 μ s for a 1 μ s pulse or set the scale to 45 μ s/div and the delay time to 4.075 μ s for a 500 μ s pulse). Press **Close** to close the window.
 - c. Select the **Vavg** button and read the measured result on the display.
8. Record the result as V_{pulse} in the test record.
9. Calculate the difference of the two voltages using the following equation, then record the result in the test record as $P_{accuracy}$.

$$P_{accuracy} = 20 \times \log\left(\frac{V_{pulse}}{V_{ref}}\right)$$
10. Repeat steps 3b to 10 for each frequency listed in the test record.
11. For models without internal pulse, repeat steps 3b to 10 using a Function Generator square wave frequency input of 500 kHz with a 25% duty cycle.
12. For models with internal pulse, repeat steps 3b to 10 using a pulse width of 0.5 μ s.

Pulse On/Off Ratio

The following procedure lets you measure the pulse on/off ratio of the MG369xB's pulse modulated RF output.

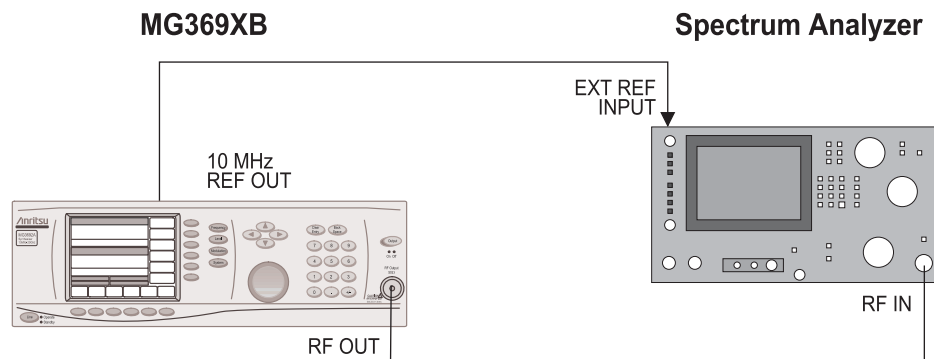

Figure 3-16. Equipment Setup for Pulse On/Off Ratio Tests

Test Setup

Set up the equipment shown in [Figure 3-16](#), as follows:

1. Connect the MG369xB's rear panel 10 MHz REF OUT to the Spectrum Analyzer's external reference input.
2. Connect the MG369xB RF Output to the Spectrum Analyzer's RF input.
3. Set up the Spectrum Analyzer as follows:
 - a. Press the **PRESET** key.
 - b. Press **AUX CTRL**.
 - c. Press the Rear Panel soft key.
 - d. Press the 10MHz soft key and set to "EXT".

Test Procedure

Measure the pulse on/off ratio as follows:

1. Set up the MG369xB as follows:
 - a. Reset the instrument by pressing **SYSTEM**, then Reset. After reset, the CW menu is displayed.
 - b. Press Edit F1 to open the current frequency parameter for editing.
 - c. Set F1 to the first/next applicable frequency in the test record for the model being tested.
 - d. Press Level to open the current power level parameter for editing and set L1 to the maximum specified leveled output power level.
 - e. Press **Modulation**, then Pulse to select the External Pulse Status menu.
 - f. Press Low RF On and ensure that the pulse mode is turned off.
2. Set up the Spectrum Analyzer as follows:
 - a. Press the **PRESET** key.
 - b. Press the **AMPLITUDE** key and enter the current power level setting of the MG369xB.
 - c. Press the **FREQUENCY** key and enter the current frequency setting of the MG369xB.
 - d. Press the **SPAN** key and enter 100 kHz.
 - e. Press the **MKR** key, then select MARKER DELTA to set the marker reference.
3. On the MG369xB's External Pulse Status menu, select On/Off to turn the pulse mode on.

Note

The signal level may drift slowly after the pulse mode is turned on. (Make the measurement as soon as possible after turning the pulse mode on.) This drift is the result of the Sample/Hold circuit not holding the level because of a very low pulse duty factor (time ratio of RF ON to RF OFF). This drift will not be present in normal pulse operation as the minimum pulse repetition rate is 100 Hz.

4. On the Spectrum Analyzer, read the marker delta value and record the value as P_{depth} in the test record.
5. Repeat steps 1a to 4 for each frequency listed in the test record.

Chapter 4 — Adjustment

4-1 Introduction

This chapter contains procedures for calibrating the series MG369xB Synthesized Signal Generators. These procedures are typically performed because out-of-tolerance conditions have been noted during performance verification testing ([Chapter 3, “Performance Verification”](#)) or as a result of replacement of subassemblies or RF components.

Note

In section 4 the word calibration and adjustment are interchangeable.

The calibration procedures herein support operating firmware version 3.36 and above. It is recommended that you upgrade your instrument’s operating firmware to the latest available version prior to calibration. Contact an Anritsu Service Center for more information.

4-2 Test Equipment List

[Table 4-1](#) provides a partial list of the test equipment for these calibration procedures. [Section 4-10](#) through [Section 4-14](#) each contain a diagram showing additional required equipment for performing RF level calibration and calibration of options. The test equipment setup is critical to making accurate measurements. In some cases, you may substitute test equipment having the same critical specifications as the test equipment indicated in the test equipment list (refer to [Section 3-5](#)).

Table 4-1. Test Equipment List (Sheet 1 of 3)

Instrument	Critical Specification	Manufacturer/Model	Usage ⁽¹⁾
Computer running Windows XP	Can not exceed the following configuration: Pentium 4 2.8 GHz 1 GB of memory 2 Serial ports CDROM Mouse Keyboard Monitor Network The computer must be dedicated during calibration and verification activities.	Dell or other common source	C, P
National Instrument PCI GPIB card	PCI GPIB card for computer	National Instrument	C, P
Anritsu RF verification and calibration software		Anritsu 2300-497	C, P
Spectrum Analyzer	Frequency: 100 kHz to 50 GHz Resolution bandwidth: 10 Hz	Agilent 8565EC	C, P
Frequency counter	For use in calibration and performance verification the critical specifications are: Frequency range: 0.01 to 20 GHz Input impedance: 50 Ω Resolution: 1 Hz Other: External time base input For use with only performance verification the critical specifications are: Frequency range: 0.01 to 6 GHz Input impedance: 50 Ω Resolution: 1 Hz Other: External time base input	For calibration and performance verification the recommendation is Anritsu model MF2414B or For performance verification the recommendation is Anritsu model MF2412B	C, P
Power meter	Frequency: 100 kHz to 67 GHz Power range: -70 to +20 dBm	Anritsu model ML2437A/38A	C, P
Power sensor for power meter	Frequency: 0.01 to 40 GHz (K) Power range: -70 to +20 dBm	Anritsu model MA2474D	C, P
Power sensor for power meter	Frequency: 0.01 to 50 GHz (V) Power range: -70 to +20 dBm	Anritsu model MA2475D	C, P
Power sensor for power meter	Frequency: 0.01 to 67 GHz (V) Power range: -30 to +20 dBm	Anritsu model SC7430 or Anritsu model SC7570	C, P
Power sensor for power meter	Frequency: 100 kHz to 18 GHz (N) Power range: -55 +20 dBm	Anritsu model SC7400	C, P
Adapter for power sensor SC7400	N female to K adapter	Anritsu model 34NFK50	C, P
Adapter for power sensor calibration	N(m) to K(f)	Anritsu 34NKF50	C, P

Table 4-1. Test Equipment List (Sheet 2 of 3)

Instrument	Critical Specification	Manufacturer/Model	Usage ⁽¹⁾
Adapters for power sensor calibration	N(m) to V(f)	Common source or Alternate to achieve N(m) to V(f): Anritsu model 34NK50 + 34VKF50 or Anritsu model 34NKF50 + 34VK50	C, P
Function generator	Frequency: 0.1 Hz to 15 MHz	Agilent 33120A	C, P
Frequency reference	Frequency: 10 MHz Accuracy: 5×10^{-12} parts/day	Absolute Time Corp., model 300 or Symmetricom (Datum) model 9390-9600	P
Measuring receiver ⁽²⁾	Noise floor: < -140 dBm @ 500 MHz	Anritsu model ML2530A	C, P
Local oscillator	Frequency: 0.01 to 40 GHz	Anritsu Model MG3694B with options: 3, 4, 16, and SM6191 (unit can not have options 2B, 15B or 22) Note: If the T2579 mixer box is ordered, then special SM6191 must be added to the LO.	C, P
Mixer box ⁽²⁾ (for low level calibration)	Frequency range: 0.01 GHz to 40 GHz	Anritsu PN: T2579	C, P
Low pass filter (Qty = 2) ⁽²⁾	1.9 GHz LPF	Mini-Circuits BPL-1.9 or Anritsu PN: 1030-104	C, P
Scalar network analyzer with RF detector	Frequency: 0.01 to 40 GHz	Anritsu model 56100A with RF detector: 560-7K50 (0.01 to 40 GHz) or 560-7VA50 (0.01 to 50 GHz)	C, T
AUX I/O interface cable	Provides interface between the instrument under test and the 56100A Scalar Network Analyzer	Anritsu PN: 806-7	C
Attenuator for instrument model numbers MG3691B through MG3694B	Frequency range: DC to 40 GHz Attenuation: 3, 6, 10, and 20 dB (sizes and counts are determined depending on options and maximum output power of instrument)	Anritsu part number SC7879 K set of attenuators (41KC-3, 41KC-6, 41KC-10, 41KC-20) calibrated from 100 K to 40 GHz or Anritsu, model 41KC-3, 41KC-6, 41KC-10 or 41KC-20 calibrated at the following data points: 100 kHz, 1 MHz, 10 MHz, 100 MHz, 500 MHz to 67 GHz in 500 MHz steps	C, P

Table 4-1. Test Equipment List (Sheet 3 of 3)

Instrument	Critical Specification	Manufacturer/Model	Usage ⁽¹⁾
Attenuator for instrument model numbers MG3695B through MG3696B	Frequency Range: DC to 65 GHz Attenuation: 3, 6, 10, and 20 dB (sizes and counts are determined depending on options and maximum output power of instrument)	Anritsu part number SC7880 V set of attenuators (41V-3, 41V-6, 41V-10, 41V-20) calibrated from 100 K to 67 GHz. or Anritsu, model 41V-3, 41V-6, 41V-10 and 41V-20 calibrated at the following data points: 100 kHz, 1 MHz, 10 MHz, 100 MHz, 500 MHz to 67 GHz in 500 MHz steps	C, P
BNC Tee	Connectors: 50Ω BNC	Any common source	C, P
Generic 50Ω BNC RF cables and connectors		Any common source	C, P
Generic GPIB cables		Any common source	C, P
BNC to SMA adapter	BNC to SMA Adapter	Any common source	P
K(m) to K(m) flex cables or semi-rigid cables	K(m) to K(m) flex cables or Semi-rigid cables	Anritsu SC3855 3670K50-2 K(m) to K(m) flex cable or Anritsu K120mm-60CM custom semi-rigid cable	C, P
V(m) to V(m) flex cables or semi-rigid cables	V(m) to V(m) flex cables or Semi-rigid cables	Anritsu APN 3670V50-2 V(m) to V(m) flex cable or Anritsu V120mm-60CM Custom Semi-rigid cable	C, P
Anritsu Cal Data Save/Recall software		Anritsu P/N: 2300-478	C
Special Serial I/O Cable Assembly	Provides interface between the MG3690B and the PC	Anritsu P/N: T1678	C, P

1. P = Performance Verification Tests, C = Calibration, T = Troubleshooting

2. Only needed if option 2X is installed.

4-3 Test Records

A blank copy of a sample calibration test record for each MG369xB model is provided in [Appendix A](#). It provides a means for maintaining an accurate and complete record of instrument calibration. We recommend that you copy these pages and use them to record your calibration of out-of-tolerance MG369xB circuits or your calibration of the MG369xB following replacement of subassemblies or RF components.

4-4 Subassembly Replacement

Table 4-2 lists the calibrations that should be performed following the replacement of many MG369xB subassemblies or RF components.

Table 4-2. Calibration Following Subassembly/RF Component Replacement

Subassembly/RF Component Replaced	Perform the Following Calibration(s) in Section(s):
Front Panel Assembly	None
A2 Microprocessor PCB	4-7 thru 4-10 (if calibration information was not transferred from original A2 board; perform calibrations steps 4-7 to 4-14)
A3 Reference Loop PCB	4-7 (and 4-10 if Option 22 is installed)
A4 Coarse Loop PCB	4-7
A5 Auxiliary PCB (without Option 6)	None
A5 Analog Instruction PCB (Option 6)	4-7, 4-12
A6A1 External AM PCB (Option 14, 25X, 28X)	4-13
A6 ALC PCB	4-8, 4-9, 4-10
A7 YIG Lock PCB	None
A7A1 External FM/ϕM PCB	4-14
A8 Function Generator	None
A9 YIG Module Assembly	4-7, 4-9, 4-10
A13 Pulse Generator	None
A20 Regulator Board	None
A21 Regulator Board	None
Power Supply	None
0.01 to 2.2 GHz Digital Down Converter Assembly (Option 4)	4-9
0.01 to 2 GHz Down Converter Assembly (Option 5)	4-8, 4-9, 4-10
All Other RF Components	4-8, 4-9, 4-10

Note Calibration is not required for items not listed in Table 4-2.

4-5 Connector and Key Notation

The calibration procedures include many references to equipment interconnections and control settings. For all MG369xB references, specific labels are used to denote the appropriate menu key, data entry key, data entry control, or connector (such as CW/SWEEP SELECT or RF OUTPUT). Most references to supporting test equipment use general labels for commonly used controls and connections (such as Span or RF Input). In some cases, a specific label is used that is a particular feature of the test equipment listed in [Table 4-1](#).

4-6 Initial Setup

The MG369xB is calibrated using a PC and external test equipment. The PC must have the Windows 95/98/ME or the Windows NT/2000/XP operating system installed and be equipped with a mouse. Initial setup consists of interfacing the PC to the MG369xB.

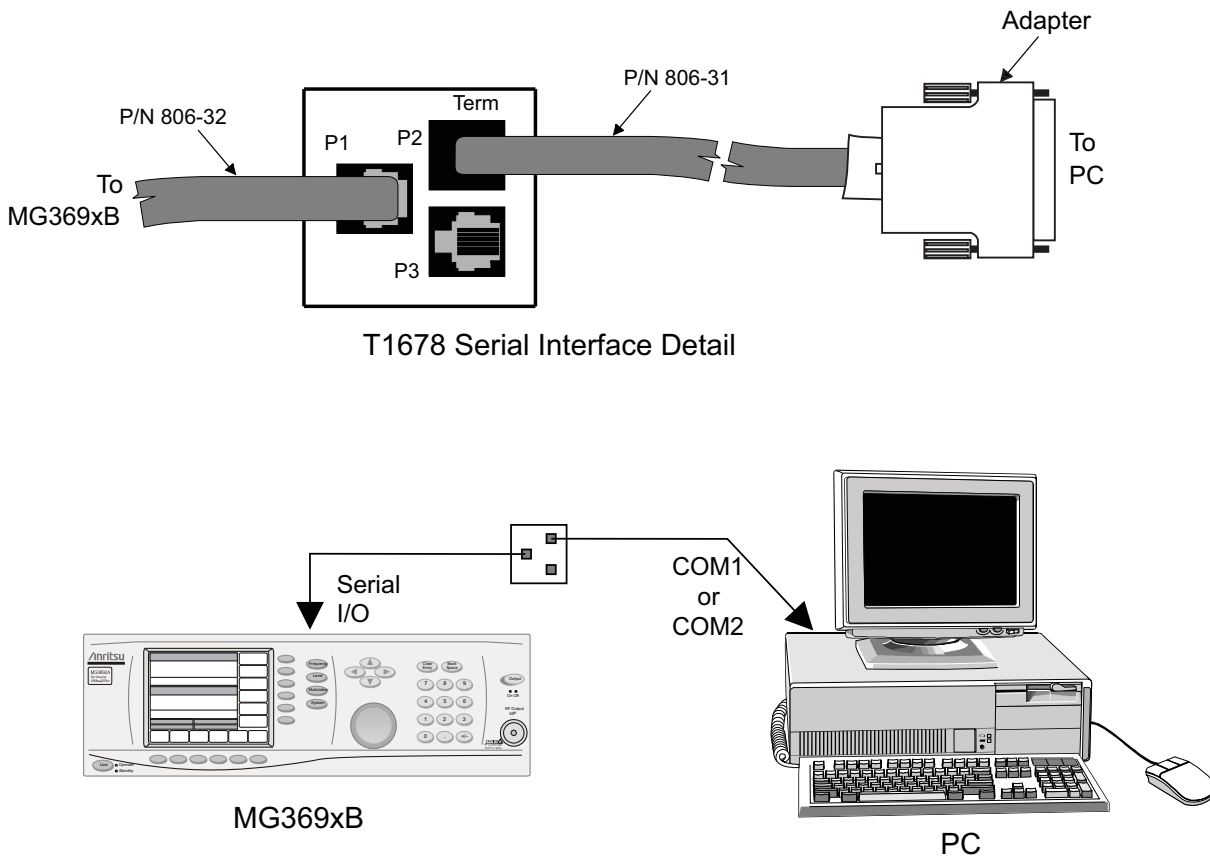

Figure 4-1. PC to MG369xB Interconnection for Calibration

Interconnection

Using an Anritsu serial interface assembly (PN: T1678), connect the PC to the MG369xB as follows:

1. Connect the wide flat cable between the MG369xB rear panel SERIAL I/O connector and the P1 connector on the T1678 serial interface PCB.
2. Connect the narrow flat cable between the P2 (TERM) connector on the T1678 serial interface PCB and the COM1 or COM2 connector on the PC. Use the RJ11-to-DB-9 or RJ11-to-DB-25 adapter, provided with the T1678 serial interface assembly, to make the connection at the PC.

PC Setup

Configure the PC with the Microsoft Windows operating system to interface with the MG369xB as follows:

1. Power on the MG369xB.
2. Power on the PC.
3. Go to Start | Programs | Accessories | Communications | HyperTerminal to start HyperTerminal (for Microsoft Windows XP). The New Connection window is shown below.

Note If HyperTerminal is not present, it will need to be installed from the Windows Setup CD.

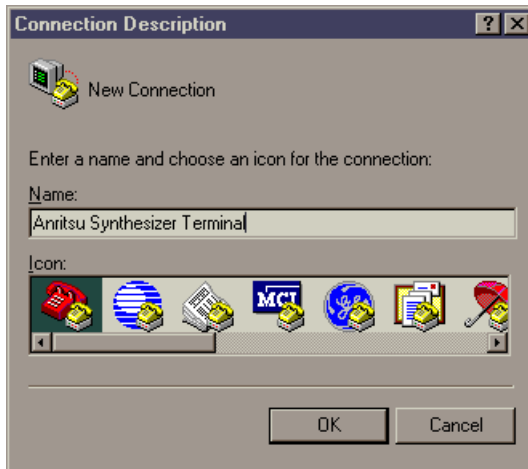

4. In the Connection Description box, type a name for the new connection, then click on the OK button. The window below is now displayed.

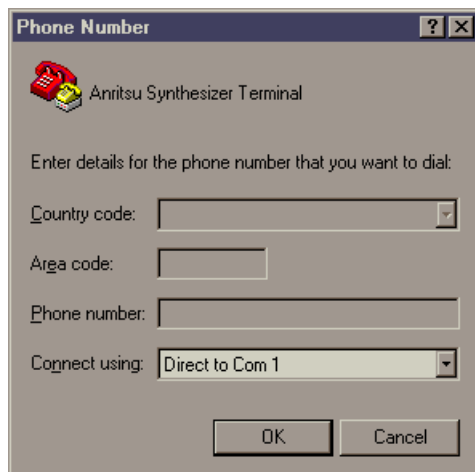

5. In the Connect using: box, type or select: Direct to Com “_” (Enter the number of the communications port being used, for example: Direct to Com 1).

6. Click OK. The Communications Port Properties window is displayed.

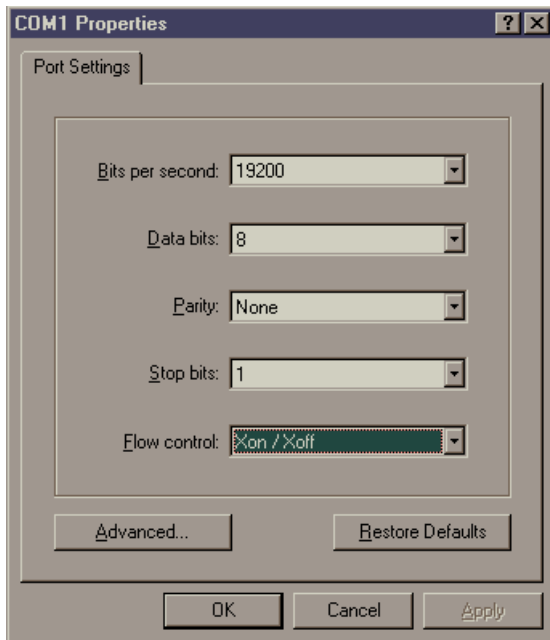

7. In the Properties window, make the following selections:

<u>B</u> its per second	19200
<u>D</u> ata bits	8
<u>P</u> arity	None
<u>S</u> top bits	1
<u>F</u> low control	Xon / Xoff

8. After making the selections, click on the OK button.

9. Press <ENTER> on the keyboard.

10. Verify that the \$ prompt appears on the PC display.

11. This completes the initial setup for calibration.

4-7 Preliminary Calibration

This procedure provides the steps necessary to initially calibrate the coarse loop, fine loop, frequency instruction, internal DVM circuitry and the 10 MHz reference oscillator of the MG369xB. If Option 16 is installed, the 10 MHz reference oscillator is calibrated.

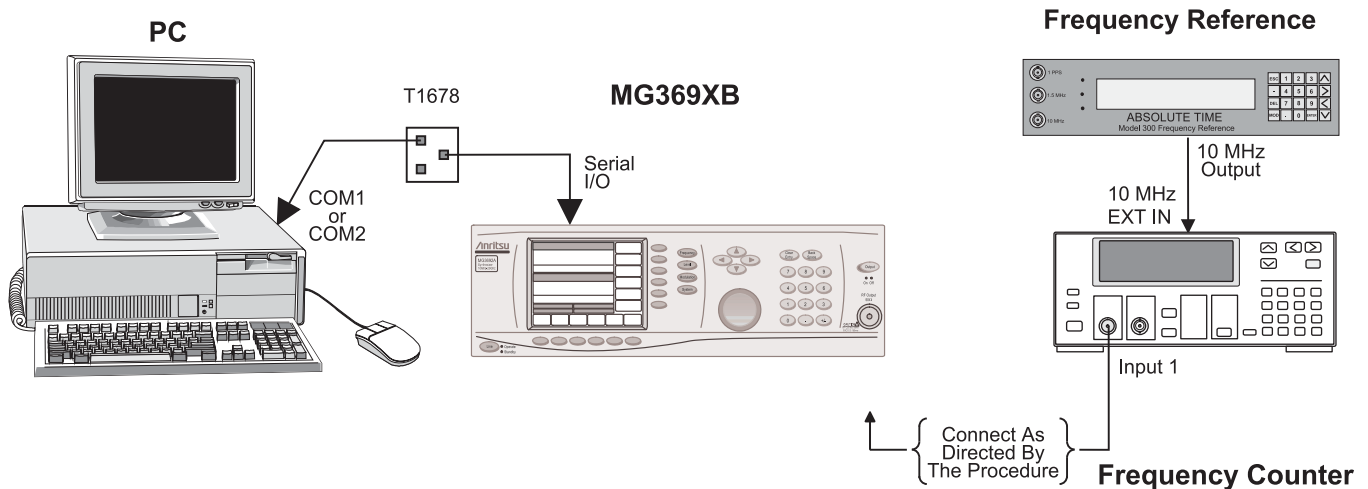

Figure 4-2. Equipment Setup for Preliminary Calibration

Equipment Setup

Connect the equipment shown in [Figure 4-2](#), as follows:

1. Interface the PC to the MG369xB by performing the initial setup procedure detailed in [Section 4-6](#).
2. Connect the frequency counter to the MG369xB when directed to do so during the calibration procedure.

Note Before beginning this calibration procedure, always let the MG369xB warm up for a minimum of one hour.

Calibration Steps

Each of the steps in this procedure provides initial calibration of a specific MG369xB circuit or component. To ensure accurate instrument calibration, each step of this procedure must be performed in sequence.

1. Calibrate the internal DVM circuitry as follows:
 - a. At the \$ prompt, type: `calterm 119` and press `<ENTER>`. The \$ prompt will appear on the screen when the calibration is complete.
 - b. Record step completion in the test record.
2. Calibrate the coarse loop pre-tune DAC as follows:
 - a. At the \$ prompt, type: `calterm 137` and press `<ENTER>`. The \$ prompt will appear on the screen when the calibration is complete.
 - b. Record step completion in the test record.

Note To save the calibration data after completing any calibration step, type: `calterm 787` and press `<ENTER>`.

3. Calibrate the sweep time DAC as follows:
 - a. At the \$ prompt, type: calterm 132 and press <ENTER>. The \$ prompt will appear on the screen when the calibration is complete.
 - b. Record step completion in the test record.
4. If option 6 is installed then calibrate the YIG offset calibration as follows:
 - a. At the \$ prompt, type: calterm 134 and press <ENTER>. The \$ prompt will appear on the screen when the calibration is complete.
 - b. Record step completion in the test record.
5. Calibrate the YIG frequency linearizer DACs as follows:
 - a. At the \$ prompt, type: calterm 127 and press <ENTER>. The \$ prompt will appear on the screen when the calibration is complete.
 - b. Record step completion in the test record.

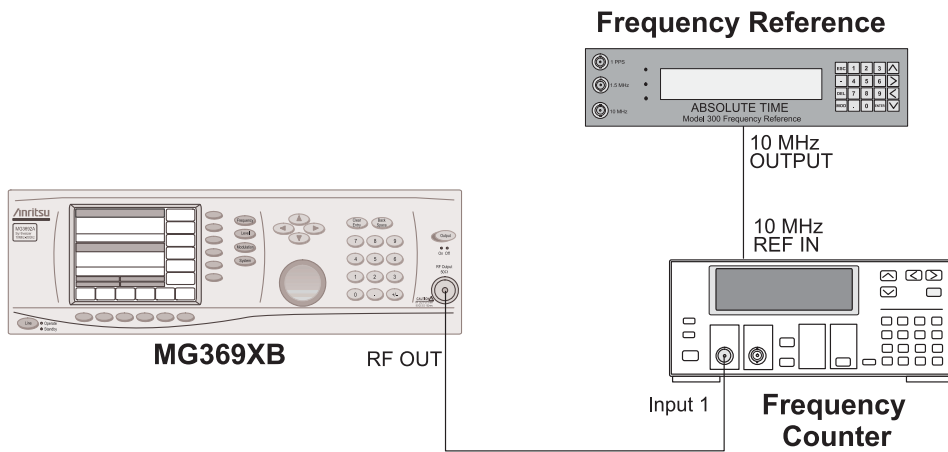

Figure 4-3. Equipment Setup for 10 MHz Reference Oscillator Calibration

6. For all MG369xB models, calibrate the 10 MHz reference oscillator per the procedure described in the steps below:
 - a. Connect the equipment as shown in [Figure 4-3](#).
 - b. Connect the frequency counter to the MG369xB RF output connector.

Note For an alternate 10 MHz reference oscillator calibration procedure, go to [step 5a](#) on the next page.

- c. At the \$ prompt, type: calterm 130 and press <ENTER>.
 - d. Follow the instructions on the screen.
 - e. Record step completion in the test record.
7. Calibrate the ramp center DAC as follows:
 - a. At the \$ prompt, type: calterm 129 and press <ENTER>. The \$ prompt will appear on the screen when the calibration is complete.
 - b. Record step completion in the test record.
8. Calibrate the sweep width DAC as follows:
 - a. At the \$ prompt, type: calterm 133 and press <ENTER>. The \$ prompt will appear on the screen when the calibration is complete.
 - b. Record step completion in the test record.

9. Calibrate the center frequency DAC as follows:

- a. At the \$ prompt, type: `calterm 114` and press <ENTER>. The \$ prompt will appear on the screen when the calibration is complete.
- b. Record step completion in the test record.

10. Store the calibration data as follows:

- a. At the \$ prompt, type: `calterm 787` and press <ENTER>. The \$ prompt will appear on the screen when the calibration data has been stored.
- b. Record step completion in the test record.

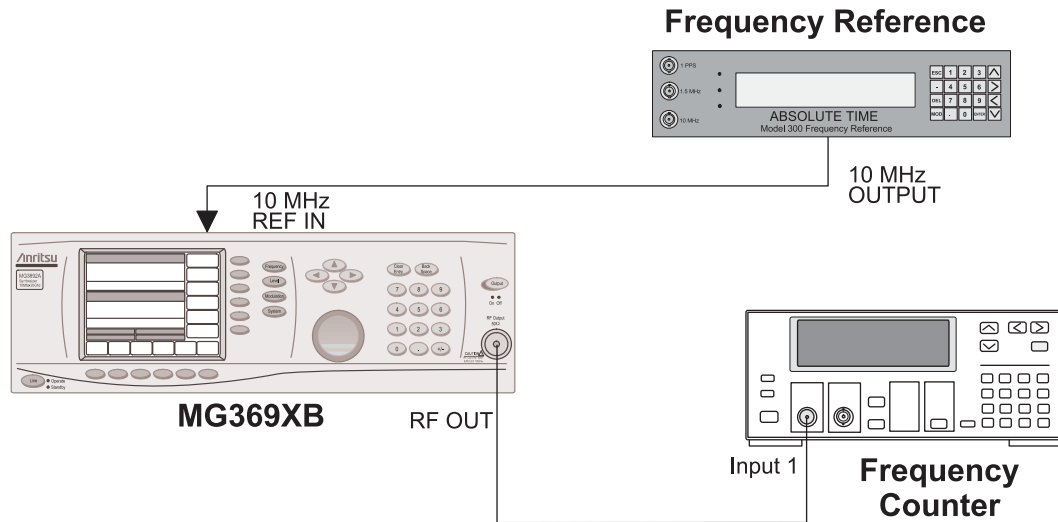

Figure 4-4. Equipment Setup for 10 MHz Reference Oscillator Calibration (Alternate Method)

Alternate 10 MHz Reference Oscillator Calibration

This 10 MHz reference oscillator calibration procedure is an alternate to [step 5](#) of [Calibration Steps](#).

Note

If this procedure is used as a substitute for step 5 of the preliminary calibration procedure, you must still perform steps 6, 7, 8, and 9 to complete the preliminary calibration of the MG369xB.

Step 5a. Calibrate the 10 MHz reference oscillator as follows:

- c. Connect the frequency reference 10 MHz OUTPUT to the 10 MHz REF IN connector on the MG369xB rear panel.
- d. On the MG369xB, press the **System** main menu key. At the System menu display, press **Cal Menu** to go to the Calibration menu.
- e. Press **Reference Cal** to begin calibration. The Calibration Status menu is displayed.
- f. Press **Proceed** to start the calibration. The date parameter opens for data entry.
- g. Using the key pad, enter the current date (in any desired format). Then, press any terminator key. The Calibration Status menu display changes to indicate calibration is in progress.
- h. When the reference oscillator calibration is complete, the Calibration menu is displayed.
- i. Record step completion in the test record.
- j. Proceed to [step 6](#) of the preliminary calibration procedure [on page 4-10](#)).

4-8 Frequency Synthesis Tests

The following tests can be used to verify correct operation of the frequency synthesis circuits, frequency synthesis testing is divided into two parts—coarse loop/YIG loop tests and fine loop tests.

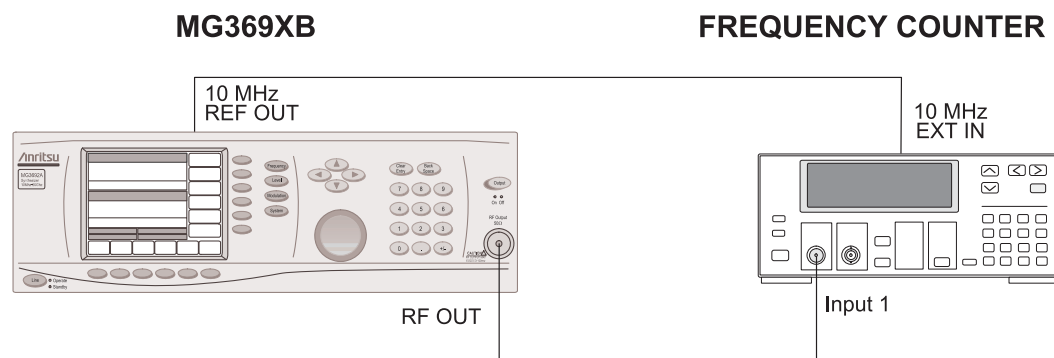

Figure 4-5. Equipment Setup for Frequency Synthesis Tests

Test Setup

Connect the equipment, shown in [Figure 4-5](#), as follows:

1. Connect the MG369xB rear panel 10 MHz REF OUT to the frequency counter's 10 MHz external reference input.
2. Connect the MG369xB RF OUTPUT to the frequency counter Input 1.

Note Before beginning this calibration procedure, let the MG369xB warm up for a minimum of one hour.

Coarse Loop/YIG Loop

The following procedure tests both the coarse loop and YIG loop by stepping the instrument through its YIG-tuned oscillator's frequency range and measuring the RF output at each step.

1. Set up the MG369xB as follows:
 - a. Reset the instrument by pressing **SYSTEM**, then Reset. After reset, the CW menu is displayed.
 - b. Press Edit F1 to open the current frequency parameter for editing.
 - c. Set F1 to the first test frequency indicated in the test record for the model being tested.
2. Record the frequency counter reading in the test record. The frequency counter reading must be within ± 100 Hz of the displayed MG369xB frequency to accurately complete this test.

Note The frequency counter reading is typically within ± 1 Hz because the instruments use a common time base. Differences of a few Hertz can be caused by noise or counter limitations. Differences of $\geq \pm 100$ Hz indicate a frequency synthesis problem.

3. On the MG369xB, use the cursor control key (arrow keys) to increment F1 to the next test frequency in the test record. Record the frequency counter reading in the test record.
4. Repeat step 3 until all frequencies listed in the test record have been recorded.

Fine Loop

The following procedure tests the fine loop by stepping the instrument through ten 100 Hz steps and measuring the RF output at each step.

Caution When saving calibration data, turning off the instrument before the \$ prompt returns to the screen can cause all stored data to be lost.

1. Set up the MG369xB as follows:
 - a. Reset the instrument by pressing **SYSTEM**, then **Reset**. After reset, the CW menu is displayed.
 - b. Press **Edit F1** to open the current frequency parameter for editing.
 - c. Set **F1** to the first test frequency indicated in the test record.
2. Record the frequency counter reading in the test record. The frequency counter reading must be within ± 10 Hz of the displayed MG369xB frequency to accurately complete this test.
3. On the MG369xB, use the cursor control key (arrow keys) to increment **F1** to the next test frequency in the test record. Record the frequency counter reading in the test record.
4. Repeat step 3 until all frequencies listed in the test record have been recorded.

4-9 Switched Filter Shaper

This procedure provides the steps necessary to adjust the switched filter shaper amplifier gain to produce a more constant level amplifier gain with power level changes.

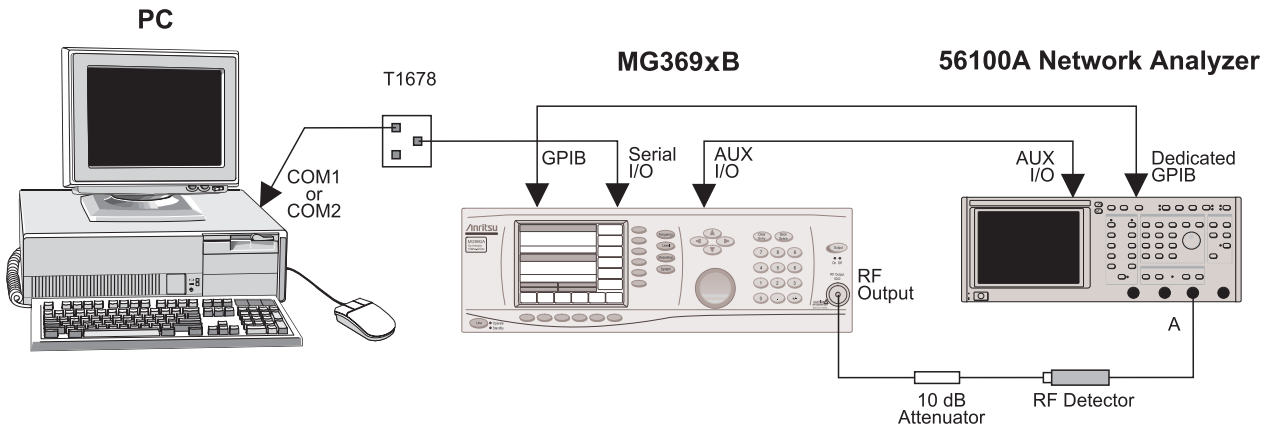

Figure 4-6. Equipment for Switched Filter Shaper Calibration

Equipment Setup

Connect the equipment, shown in [Figure 4-6](#), as follows:

1. Interface the PC to the MG369xB by performing the initial setup procedure, see [“Initial Setup” on page 4-6](#).
2. Using the auxiliary I/O cable, connect the MG369xB rear panel AUX I/O connector to the network analyzer’s AUX I/O connector.
3. Using the GPIB cable, connect the network analyzer’s DEDICATED GPIB connector to the MG369xB IEEE-488 GPIB connector.

Note	In some cases the unit's GPIB identification needs to be changed to 68/69 ID in order to obtain communication between the MG3690C and the 56100A. To do this press System, config, GPIB, More, and 68/69 ID.
-------------	--

4. Connect the RF detector to the network analyzer Channel A input connector.
5. Connect the MG369xB RF OUTPUT connector to the RF detector via a 10 dB attenuator.

Note	Before beginning this calibration procedure, let the MG369xB warm up for a minimum of one hour.
-------------	---

Log Amplifier Zero Calibration

Before the switched filter shaper amplifier can be adjusted, zero calibration of the ALC log amplifier must be performed to eliminate any DC offsets. Perform ALC log amplifier zero calibration as follows:

1. At the \$ prompt on the PC display, type: calterm 115 and press <ENTER>
2. The \$ prompt will appear on the screen when ALC log amplifier zero calibration is complete. This can take up to three minutes for a 40 GHz instrument.
3. Record step completion in the test record.

Limiter DAC Adjustment

Note

The following limiter DAC adjustment procedure applies only to MG369xB with Option 15 (high power output). If your instrument does not have this option, check the “Limiter DAC Adjustment” calibration values are set to default. To do this enter calterm 145 and press **Q** at each test (do not change the values) until you exit the calibration. Continue with the “Shaper DAC Adjustment” on page 4-16 procedure.

The following steps in the procedure let you adjust the switched filter limiter DAC which controls the maximum gain of the switched filter shaper amplifier. Each frequency band will be scanned for the maximum unlevelled power point before adjustment of the limiter DAC to ensure that the shaper amplifier is not driven to saturation.

1. Set up the 56100A network analyzer as follows:
 - a. Press the **System** menu key.
 - b. From the System menu display, select RESET.
 - c. Press CHANNEL 2 DISPLAY: OFF.
 - d. Press CHANNEL 1 DISPLAY: ON.
 - e. Press the CHANNEL 1 MENU key.
 - f. From the Channel 1 menu display, select POWER.
 - g. Press OFFSET/RESOLUTION.
 - h. Set the resolution to 5 dB/Div.
 - i. Adjust the offset to center the display.
2. Adjust the switched filter limiter DAC for each of the frequency bands as follows:
 - a. At the \$ prompt on the PC display, type: calterm 145 and press <ENTER>.
 - b. On the 56100A network analyzer, set the resolution to 0.2 dB and adjust the offset to center the top of the waveform on the display.
 - c. Observe the displayed waveform to determine whether the shaper amplifier is being driven to saturation. This is indicated by a dip in the top of the waveform (Figure 4-7).

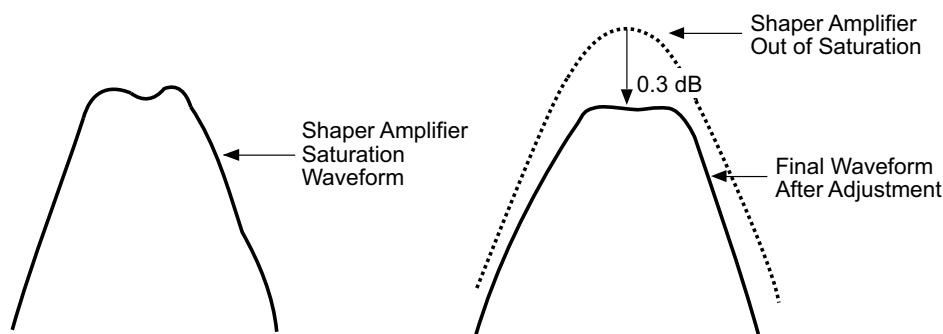

Figure 4-7. Limiter DAC Adjustment Waveforms

- d. If the displayed waveform indicates that there is no saturation, proceed to step f. If there is a dip in the waveform, go to step e.
- e. On the computer keyboard, use **8**, **9**, or **0** to decrement the value of the DAC's setting until the top of the waveform starts to become rounded at the edges (the shaper amplifier is no longer being driven to saturation). during this process keeping as much power as possible. Continue decrementing until the top of the waveform is 0.3 dB below this point.

- f. Press **Q** on the keyboard to go to the next frequency band.
- g. Repeat steps c through f until the DAC has been checked and adjusted for all frequency bands.
- h. Press **Q** on the keyboard to exit the program. The \$ prompt will appear on the screen.
- i. Record step completion in the test record.

Shaper DAC Adjustment

The following step in the procedure adjusts the switch filter shaper DAC which controls the gain of the switched filter shaper amplifier. Each frequency band will be scanned for the minimum unleveled power point before automatic adjustment of the shaper DAC.

1. At the \$ prompt on the PC display, type: `calterm 138` and press <ENTER>. The \$ prompt will appear on the screen when the calibration is complete.

Note	The calibration routine may take up to 20 minutes depending on the frequency range of the MG369xB being calibrated.
-------------	---

2. Store the calibration data in non-volatile memory on the A2 CPU PCB as follows:
 - a. Type: `calterm 787` and press <ENTER>. The \$ prompt will appear on the screen when the data has been stored.

Caution	When saving calibration data, turning off the instrument before the \$ prompt returns to the screen can cause all stored data to be lost.
----------------	---

- b. Record step completion in the test record.

4-10 RF Level Calibration

RF level calibration requires the use of an automated test system. A computer-controlled power meter measures the MG369xB power output at many frequencies throughout the frequency range of the instrument. Correction factors are then calculated and stored in non-volatile memory located on the A2 microprocessor PCB.

RF level calibration is required following replacement of any of the following assemblies:

- A6 ALC PCB
- A3 (only if Option 22 is installed)
- A9 YIG Assembly
- Switched Filter Assembly
- Down Converter Assembly (Option 5)
- Digital Down Converter Assembly (Option 4)
- Switched Doubler Module
- Switched Quadrupler Module
- Forward Coupler
- Directional Coupler
- Step Attenuator
- Diplexers
- Power Amplifier (Option 15x)
- Transfer Switch (Option 20)

The test equipment list is shown in [Table 4-3](#).

Table 4-3. Test Equipment List (Sheet 1 of 2)

Instrument	Critical Specification	Manufacturer/Model	Usage ⁽¹⁾
Computer running Windows XP	Can not exceed the following configuration: Pentium 4 2.8 GHz 1 GB of memory 2 Serial ports CDROM Mouse Keyboard Monitor Network The computer must be dedicated during calibration and verification activities.	Dell or other common source	C, P
National Instrument PCI GPIB card	PCI GPIB card for computer	National Instrument	C, P
Anritsu RF verification and calibration software		Anritsu 2300-497	C, P
Power meter	Frequency: 100 kHz to 67 GHz Power range: -70 to +20 dBm	Anritsu model ML2437A/38A	C, P
Power sensor for power meter	Frequency: 0.01 to 40 GHz (K) Power range: -70 to +20 dBm	Anritsu model MA2474D	C, P
Power sensor for power meter	Frequency: 0.01 to 50 GHz (V) Power range: -70 to +20 dBm	Anritsu model MA2475D	C, P
Power sensor for power meter	Frequency: 0.01 to 67 GHz (V) Power range: -30 to +20 dBm	Anritsu model SC7430 or Anritsu model SC7570	C, P
Power sensor for power meter	Frequency: 100 kHz to 18 GHz (N) Power range: -55 +20 dBm	Anritsu model SC7400	C, P
Adapter for power sensor SC7400	N female to K adapter	Anritsu model 34NFK50	C, P
Adapter for power sensor calibration	N(m) to K(f)	Anritsu 34NKF50	C, P
Adapters for power sensor calibration	N(m) to V(f)	Common source or Alternate to achieve N(m) to V(f): Anritsu model 34NKF50 + 34VKF50 or Anritsu model 34NKF50 + 34VK50	C, P
Special AUX I/O cable assembly	Provides interface between the MG369xB and the power meter	Anritsu PN: 806-97	P
Measuring receiver ⁽²⁾	Noise floor: < -140 dBm @ 500 MHz	Anritsu model ML2530A	C, P
Local oscillator	Frequency: 0.01 to 40 GHz	Anritsu Model MG3694B with options: 3, 4, 16, and SM6191 (unit can not have options 2B, 15B or 22) Note: If the T2579 mixer box is ordered, then special SM6191 must be added to the LO.	C, P

Table 4-3. Test Equipment List (Sheet 2 of 2)

Instrument	Critical Specification	Manufacturer/Model	Usage ⁽¹⁾
Mixer box ⁽²⁾ (for low level calibration)	Frequency range: 0.01 GHz to 40 GHz	Anritsu PN: T2579	C, P
Low pass filter (Qty = 2) ⁽²⁾	1.9 GHz LPF	Mini-Circuits BPL-1.9 or Anritsu PN: 1030-104	C, P
Attenuator for instrument model numbers MG3691B through MG3694B	Frequency range: DC to 40 GHz Attenuation: 3, 6, 10, and 20 dB (sizes and counts are determined depending on options and maximum output power of instrument)	Anritsu part number SC7879 K set of attenuators (41KC-3, 41KC-6, 41KC-10, 41KC-20) calibrated from 100 K to 40 GHz or Anritsu, model 41KC-3, 41KC-6, 41KC-10 or 41KC-20 calibrated at the following data points: 100 kHz, 1 MHz, 10 MHz, 100 MHz, 500 MHz to 67 GHz in 500 MHz steps	C, P
Attenuator for instrument model numbers MG3695B through MG3696B	Frequency Range: DC to 65 GHz Attenuation: 3, 6, 10, and 20 dB (sizes and counts are determined depending on options and maximum output power of instrument)	Anritsu part number SC7880 V set of attenuators (41V-3, 41V-6, 41V-10, 41V-20) calibrated from 100 K to 67 GHz. or Anritsu, model 41V-3, 41V-6, 41V-10 and 41V-20 calibrated at the following data points: 100 kHz, 1 MHz, 10 MHz, 100 MHz, 500 MHz to 67 GHz in 500 MHz steps	C, P
BNC Tee	Connectors: 50Ω BNC	Any common source	C, P
Generic 50Ω BNC RF cables and connectors		Any common source	C, P
Generic GPIB cables		Any common source	C, P
K(m) to K(m) flex cables or semi-rigid cables	K(m) to K(m) flex cables or Semi-rigid cables	Anritsu SC3855 3670K50-2 K(m) to K(m) flex cable or Anritsu K120mm-60CM custom semi-rigid cable	C, P
Anritsu Cal Data Save/Recall software		Anritsu P/N: 2300-478	C
Special Serial I/O Cable Assembly	Provides interface between the MG3690B and the PC	Anritsu P/N: T1678	C, P

1. P = Performance Verification Tests, C = Calibration, T = Troubleshooting

2. Only needed if option 2X, Anritsu Model T2579 Level Calibration Mixer Fixture, is installed. For more information, contact your Anritsu service center (<http://www.anritsu.com/Contact.asp>).

Note The T2579 mixer fixture can be built using the information provided in [Figure 4-8](#).

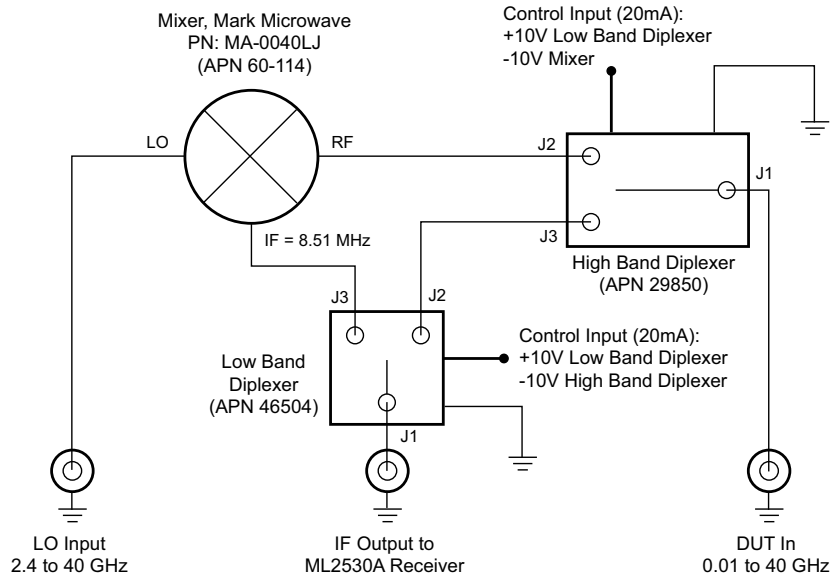

Figure 4-8. T2579 Mixer Fixture Block Diagram

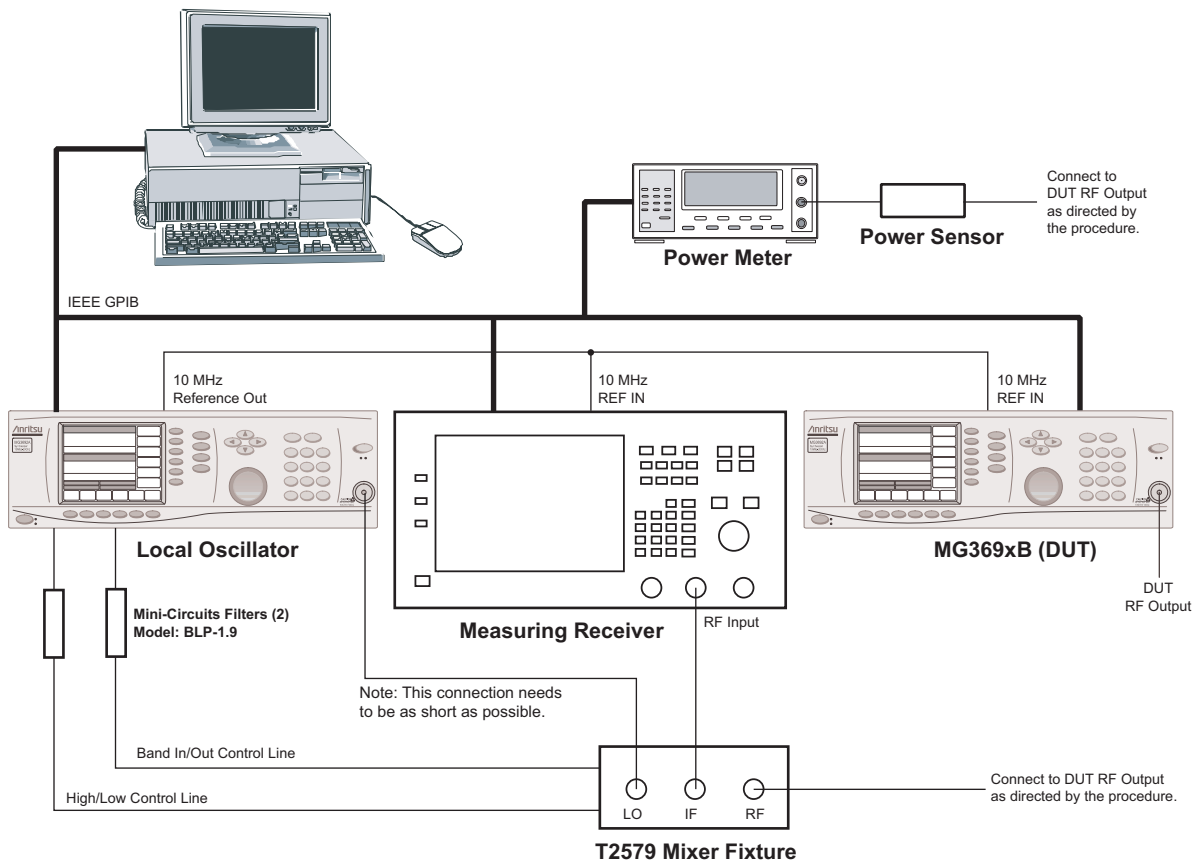

Figure 4-9. Equipment Setup for Level Calibration

Equipment Setup

Connect the equipment, shown in [Figure 4-9](#), as follows:

Note

Before beginning this calibration procedure, always let the MG369xB warm up for a minimum of one hour.

Refer to the Local Oscillator's SM6191 documentation for information on connecting the T2579 control lines.

1. Connect the PC IEEE GPIB to the MG369xB, Local Oscillator, Measuring Receiver, and Power Meter.
2. Using a BNC tee, connect the 10 MHz reference output from the local oscillator's 10 MHz REF OUT to the measuring receiver's and MG369xB's 10 MHz reference input connectors.
3. Connect the Rear Panel High/Low and Band In/Out control lines to the Local Oscillator's corresponding rear panel inputs with the Mini-Circuits low pass filters in-line.
4. Connect the RF OUTPUT of the Local Oscillator to the LO port on the T2579, and connect the IF port of the T2579 to the RF Input port of the measuring receiver.
5. Run the Level Calibration software and follow the on-screen prompts.

4-11 ALC Bandwidth Calibration

This procedure provides the steps necessary to perform ALC Bandwidth calibration. The ALC Bandwidth is adjusted to compensate for gain variations of the modulator. The adjustment is performed for each frequency band. This provides a more consistent bandwidth throughout the frequency range of the instrument.

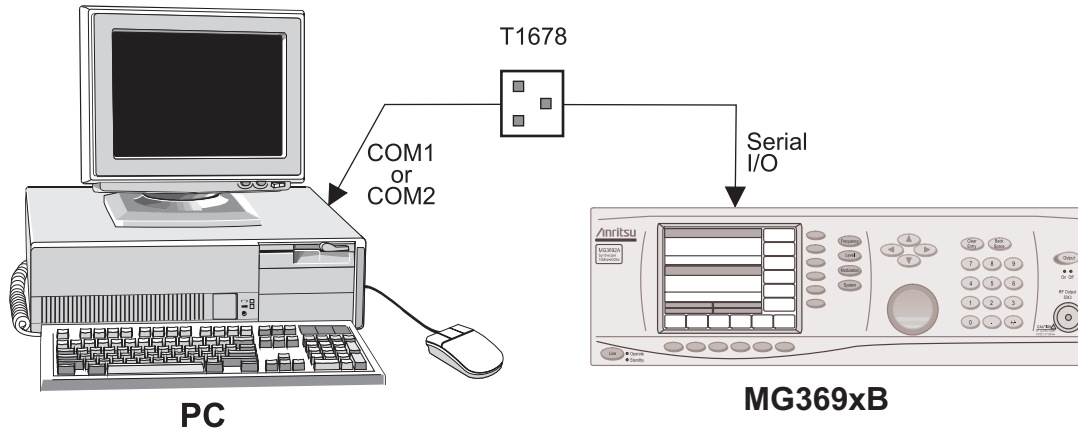

Figure 4-10. Equipment Setup for ALC Bandwidth Calibration

Equipment Setup

Connect the equipment, shown in [Figure 4-10](#), as follows:

1. Interface the PC to the MG369xB by performing the initial setup procedure, see [“Initial Setup” on page 4-6](#).
2. Connect a 50Ω termination to the RF OUTPUT connector.

Note Before beginning this calibration procedure, *a/ways* let the MG369xB warm up for a minimum of one hour.

Bandwidth Calibration

The following procedure lets you (1) calibrate the ALC bandwidth and (2) store the calibration data in non-volatile memory on the A2 CPU PCB.

1. Enter the ALC bandwidth calibration routine as follows:
 - a. At the \$ prompt on the PC display, type: `calterm 110` and press <ENTER>.
 - b. The \$ prompt will appear on the screen when the ALC bandwidth calibration is complete. This can take up to 15 minutes depending on the frequency range of the MG369xB.
 - c. Record step completion in the test record.
2. Store the calibration data as follows:
 - a. At the \$ prompt, type: `calterm 787` and press <ENTER>. (The \$ prompt will appear on the screen when the calibration data has been stored.)
 - b. Record step completion in the test record.

Note When saving calibration data, turning off the instrument before the \$ prompt returns to the screen can cause all stored data to be lost.

4-12 ALC Slope Calibration (Option 6 only)

This procedure provides the steps necessary to perform ALC Slope calibration. The ALC Slope is calibrated to adjust for decreasing output power-vs-output frequency in full band analog sweep.

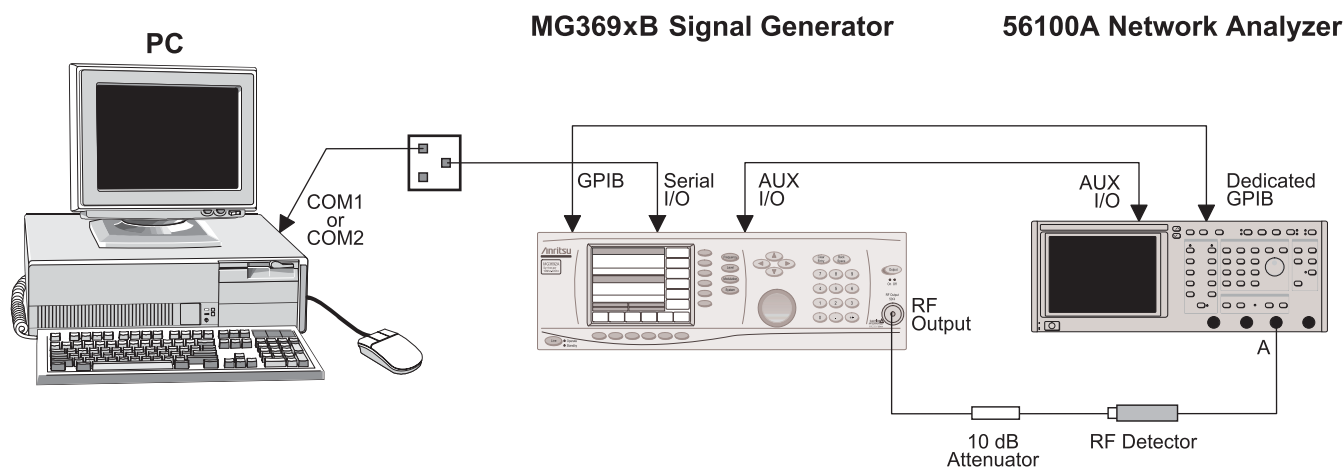

Figure 4-11. Equipment Setup for ALC Slope Calibration

Equipment Setup

Connect the equipment, shown in [Figure 4-11](#), as follows:

1. Interface the PC to the MG369xB by performing the initial setup procedure, see [“Initial Setup” on page 4-6](#).
2. Using the Auxiliary I/O cable (Anritsu PN: 806-7), connect the MG369xB rear panel AUX I/O connector to the 56100A Network Analyzer AUX I/O connector.
3. Using the GPIB cable, connect the 56100A Network Analyzer DEDICATED GPIB connector to the MG369xB IEEE-488 GPIB connector.
4. Connect the RF Detector to the 56100A Network Analyzer Channel A Input connector.
5. Connect the MG369xB RF OUTPUT connector to the RF Detector via a 10 dB Attenuator.

Note Before beginning this calibration procedure, *always* let the MG369xB warm up for a minimum of one hour.

ALC Slope DAC Adjustment (only for units with Option 6 Analog Sweep)

The following procedure lets you adjust the ALC Slope over individual frequency ranges to compensate for decreasing output power-vs-frequency in analog sweep.

The procedure begins by letting you adjust the ALC Slope for band 0 (0.01 to 2.0 GHz), if installed. It then continues letting you adjust the ALC Slope from 2 GHz to the top frequency of the instrument in up to four bands. The band frequency ranges are:

- Band 1: 2.0 to 8.4 GHz
- Band 2: 8.4 to 20.0 GHz
- Band 3: 20.0 to 40.0 GHz
- Band 4: 40.0 to 65.0 or 67.0 GHz

Note For instruments with Option 4, the frequency range for Band 1 is 2.2 to 8.4 GHz. Skip adjustment of Band 0 as full band analog sweep is not available below 2.2 GHz.

During band 1 thru 3/4 ALC Slope adjustment, the 56100A Network Analyzer display (Figure 4-12) shows the response from 2 GHz to the top frequency of the model, as adjustment is done band by band.

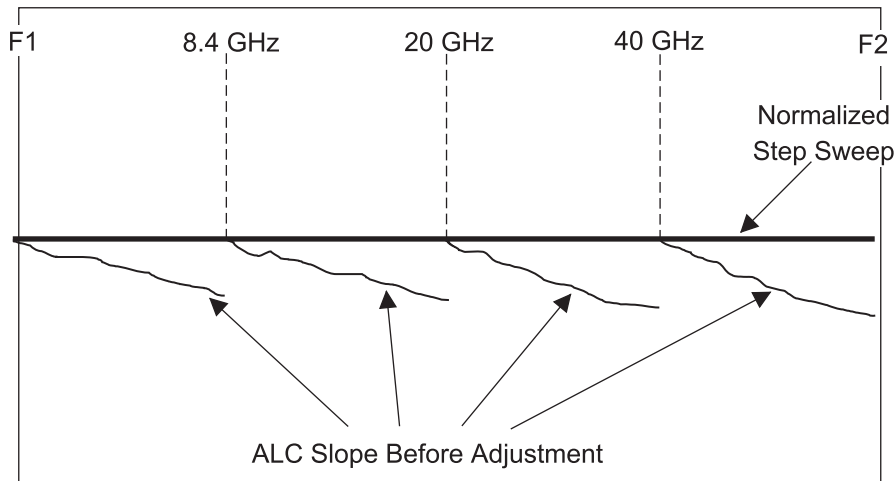

Figure 4-12. ALC Slope Adjustment Waveform Display

1. Set up the 56100A Network Analyzer as follows:
 - a. Press the System Menu key.
 - b. From the System Menu display, select RESET.
 - c. Press CHANNEL 2 DISPLAY: OFF.
 - d. Press CHANNEL 1 DISPLAY: ON.
 - e. Press CHANNEL 1 MENU key.
 - f. From the Channel 1 Menu Display, select POWER and SELECT INPUT (NON-RATIO A).
2. Set up the MG369xB as follows:
 - a. Reset the instrument by pressing **SYSTEM** then Reset. After reset the CW Menu is displayed.
 - b. Press Step Sweep. The Step Sweep Menu is displayed.
 - c. Press Frequency Control, then Full to select the full frequency range of the instrument being calibrated.
 - d. Press More, then Number of Steps and set the number of steps to 400.
3. Make the following selections on the 56100A Network Analyzer to normalize the step sweep.
 - a. Press **MENU** and select TRACE MEMORY on the display.
 - b. Select TRACE MEMORY STORAGE MENU, then TRACE DATA.
 - c. Select SUBTRACT MEMORY ON.
 - d. Press OFFSET/RESOLUTION and set the Resolution to 0.5 dB.
4. On the MG369xB, press Analog Sweep to select the analog sweep mode.
5. Adjust the ALC Slope as follows:
 - a. At the \$ prompt on the PC display, type: slpcal and press <ENTER>.

On the computer keyboard, the adjustment keys are:

Slope (all bands)	E (Up)	D (Down)
Offset (band 0, 2 to 4 only)	Q (Up)	A (Down)

4-13 AM Calibration

This procedure provides the steps necessary to perform AM calibration. This consists of calibrating the AM Calibration DAC and the AM Meter circuit. The AM Calibration DAC is calibrated for input sensitivities of 100%/V (linear mode) and 25 dB/V (logarithmic mode) for frequencies ≤ 2 GHz and > 2 GHz (≤ 2.2 GHz and > 2.2 GHz for instruments with Option 4).

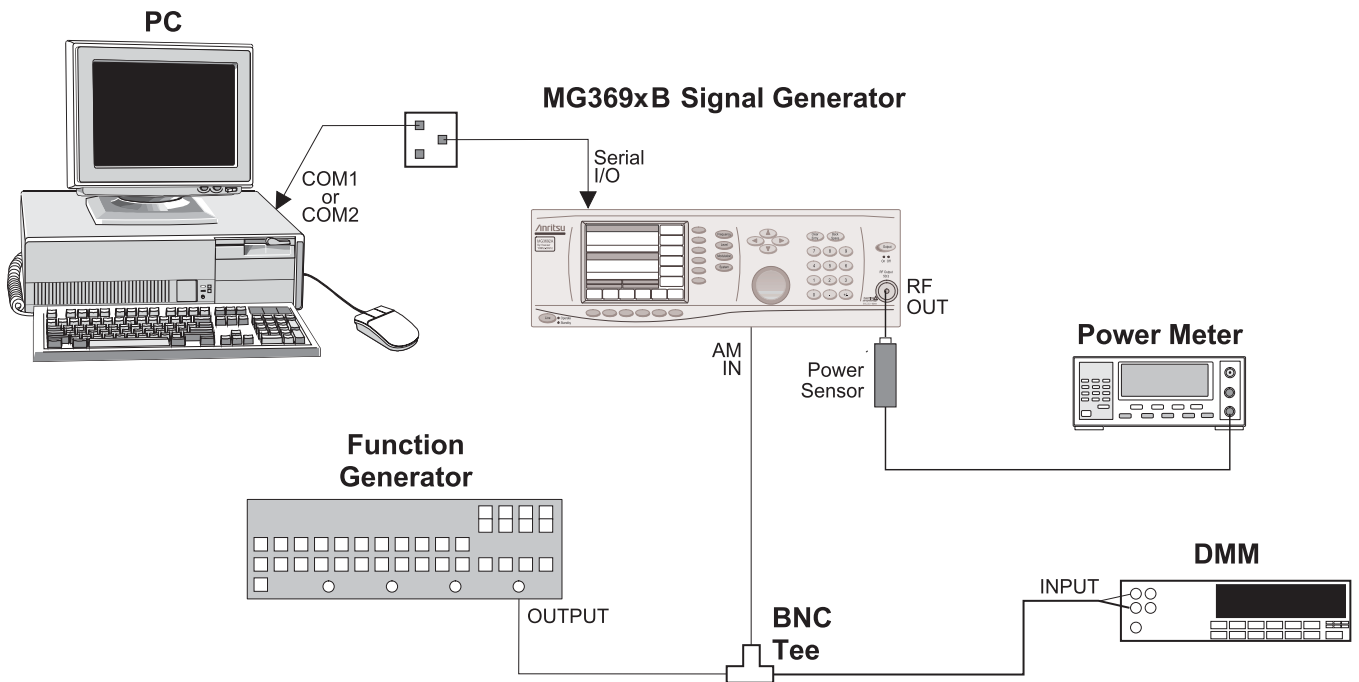

Figure 4-13. Equipment Setup for AM Calibration

Equipment Setup

Connect the equipment, shown in [Figure 4-13](#), as follows:

1. Interface the PC to the MG369xB by performing the initial setup procedure, see [“Initial Setup” on page 4-6](#).
2. Connect the Function Generator Output to the BNC tee. Connect one leg of the BNC tee to the MG369xB rear panel AM IN. Connect the other leg of the BNC tee to the DMM input.
3. Calibrate the Power Meter with the Power Sensor.
4. Connect the Power Sensor to the RF OUTPUT of the MG369xB.

Note

For the ≤ 40 GHz models, use the MA2474A power sensor; for > 40 GHz models, use the MA2475A power sensor.

AM Calibration Procedure

The following procedure lets you (1) adjust the AM Calibration DAC to provide the correct amount of AM in both linear (100%/V sensitivity) and log (25 dB/V sensitivity) modes of operation for frequencies of ≤ 2 GHz and > 2 GHz, (2) calibrate the AM Meter circuit, and (3) store the results in non-volatile memory on the A2 CPU PCB.

Note Before beginning this calibration procedure, *always* let the MG369xB warm up for a minimum of one hour.

For instruments with Option 4 installed, the procedure for Linear AM and Log AM calibration must be performed twice—once for frequencies of ≤ 2.2 GHz and once for frequencies > 2.2 GHz.

Upon initial completion of each procedure, the program will automatically return you to the start to repeat the procedure.

1. Set up the Function Generator as follows:
 - a. Mode: EXT
 - b. Signal: Square Wave
2. Perform Linear AM calibration in HET and main bands as follows:
 - a. At the \$ prompt on the PC screen, type: calterm 112 and press <ENTER>.
 - b. Set the Function Generator to output 0.00 volts. When done, press any key on the keyboard to continue calibration.
 - c. Now, set the Function Generator to output ± 0.50 volts. Use the COMPL button on the Function Generator to toggle the output between +0.50 volts and -0.50 volts.
 - d. On the computer keyboard, use 1, 2 or 3 to increment and 8, 9 and 0 to decrement the value of the DAC's setting to obtain a 9.54 dB difference in the power meter's reading when the Function Generator's output is toggled.
 - e. When the DAC has been adjusted, press **Q** on the keyboard to exit the program. (If the instrument has a Down Converter installed, you will be returned to the start of the program to perform this calibration for frequencies of > 2 GHz.)When the DAC has been completely adjusted, the program will exit to the \$ prompt.
 - f. Record step completion on the test record.

Note To save the calibration data after completing any calibration step, type: calterm 787 and press <ENTER>

3. If unit is MG3693B to MG3696B and the firmware 3.36 or higher perform the Linear AM calibration in the SDM band as follows:
 - a. At the \$ prompt on the PC screen, type: calterm 172 and press <ENTER>.
 - b. Set the Function Generator to output 0.00 volts. When done, press any key on the keyboard to continue calibration.
 - c. Now, set the Function Generator to output ± 0.50 volts. Use the **COMPL** button on the Function Generator to toggle the output between +0.50 volts and -0.50 volts.
 - d. On the computer keyboard, **1**, **2**, or **3** to increment and **8**, **9**, and **0** to decrement the value of the DAC's setting to obtain a 9.54 dB difference in the power meter's reading when the Function Generator's output is toggled.
 - e. When the DAC has been adjusted, press **Q** on the keyboard to exit the program. When the DAC has been completely adjusted, the program will exit to the \$ prompt.
 - f. Record step completion on the test record.

4. Perform Log AM calibration as follows:
 - a. At the \$ prompt, type: **calterm 113** and press <ENTER>.
 - b. Set the Function Generator for a ± 0.20 volt output. Use the **COMPL** button to toggle the output between -0.20 volts and $+0.20$ volts.
 - c. On the computer keyboard, use **1**, **2**, or **3** to increment and **8**, **9**, and **0** to decrement the value of the DAC's setting to obtain a 10.00 dB difference in the power meter's reading when the Function Generator's output is toggled.
 - d. When the DAC has been adjusted, press **Q** on the keyboard to exit the program.
When the DAC has been completely adjusted, the program will exit to the \$ prompt.
 - e. Record step completion on the test record.
5. If unit is MG3693B to MG3696B and has firmware 3.36 or higher perform the Log AM calibration in the SDM band as follows:
 - a. At the \$ prompt on the PC screen, type: **calterm 173** and press <ENTER>.
 - b. Set the Function Generator for a ± 0.20 volt output. Use the **COMPL** button to toggle the output between -0.20 volts and $+0.20$ volts.
 - c. On the computer keyboard, use **1**, **2**, or **3** to increment and **8**, **9**, and **0** to decrement the value of the DAC's setting to obtain a 10 dB difference in the power meter's reading when the Function Generator's output is toggled.
 - d. When the DAC has been adjusted, press **Q** on the keyboard to exit the program. (If the instrument has a Down Converter installed, you will be returned to the start of the program to perform this calibration for frequencies of > 2 GHz.) When the DAC has been completely adjusted, the program will exit to the \$ prompt.
 - e. Record step completion on the test record.
6. If the unit has an internal function generator (LF generator option 23, 25X, 27 or 28X) perform the AM function generator calibration as follows:
 - a. At the \$ prompt on the PC screen, type: **calterm 146** and press <ENTER>.
 - b. The \$ prompt will appear on the screen when the AM function generator calibration is complete. This can take up to 2 minutes depending on the frequency range of the MG369xB.
 - c. Record step completion in the test record.
7. Perform AM Meter calibration as follows:
 - a. At the \$ prompt, type: **calterm 147** and press <ENTER>.
 - b. Set up the Function Generator for a 1 kHz sine wave with an output level of 0.354 volts RMS (1 volt peak to peak). When done, press any key on the keyboard to continue calibration.
 - c. The \$ prompt will appear on the screen when the calibration is complete.
 - d. Record step completion on the test record.
8. Store the calibration data as follows:
 - a. At the \$ prompt, type: **calterm 787** and press <ENTER>. (The \$ prompt will appear on the screen when the calibration data has been stored.)
 - b. Record step completion on the test record.

Caution

When saving calibration data, turning off the instrument before the \$ prompt returns to the screen can cause all stored data to be lost.

4-14 Frequency and Phase Modulation Calibration

This procedure provides the steps necessary to perform FM and Φ M calibration. This consists of calibrating the FM and Φ M Meter circuit and the FM Gain Control DAC. The FM and Φ M Gain Control DAC is calibrated for input sensitivities in both narrow and wide FM and Φ M modes.

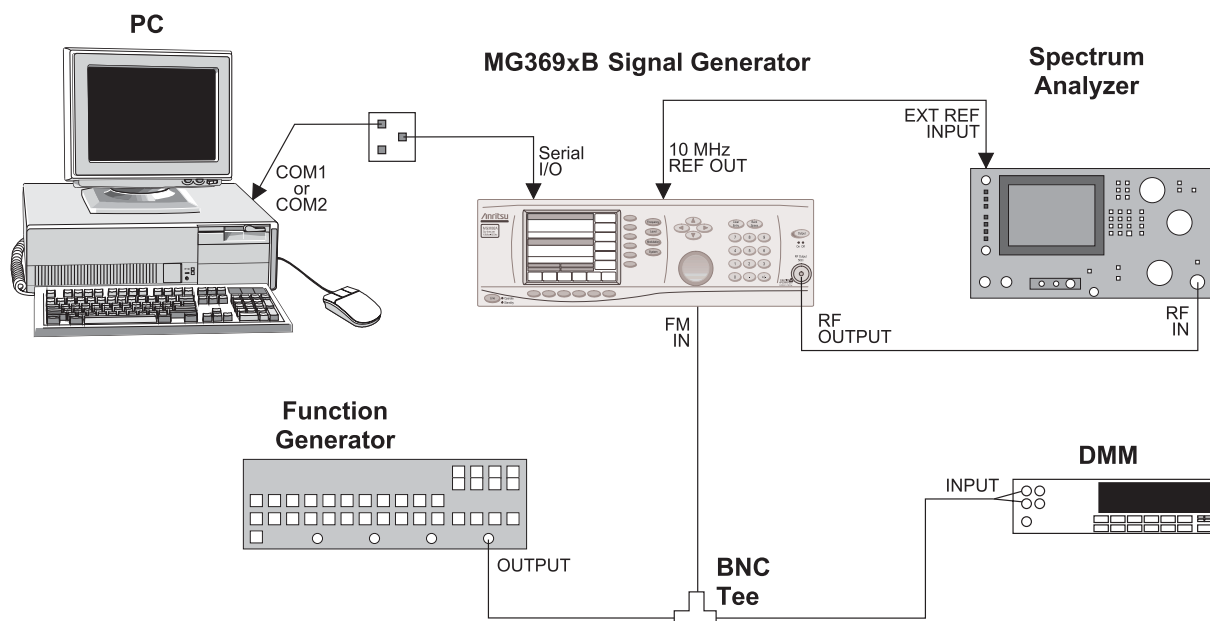

Figure 4-14. Equipment Setup for FM and Φ M Calibration

Equipment Setup

Connect the equipment, shown in [Figure 4-14](#), as follows:

1. Interface the PC to the MG369xB by performing the initial setup procedure, see [“Initial Setup” on page 4-6](#).
2. Connect the MG369xB rear panel 10 MHz REF OUT to the Spectrum Analyzer External Reference input.
3. Connect the Function Generator Output to the BNC tee. Connect one leg of the BNC tee to the MG369xB rear panel FM IN. Connect the other leg of the BNC tee to the DMM input.
4. Connect the MG369xB RF OUTPUT to the Spectrum Analyzer RF Input.

Note

Before beginning this calibration procedure, always let the MG369xB warm up for a minimum of one hour.

FM Calibration Procedure

The following steps in the procedure lets you calibrate the following and store the results in non-volatile memory on the A2 CPU PCB.

Note To ensure an accurate calibration, each step of this procedure must be performed in sequence.

1. FM Variable gain linearity
2. FM Narrow mode sensitivity
3. FM Wide mode sensitivity
4. FM External Wide mode sensitivity
5. FM External Narrow mode sensitivity
6. FM Wide flatness
7. FM Narrow flatness
8. FM Meter circuit
9. FM Function generation

Note To save the calibration data after completing any calibration step, type: calterm 787 and press <ENTER>

1. FM Variable gain linearity calibration is accomplished by adjusting the gain while the input from the function generator is at +1 V DC. Perform the calibration as follows:
 - a. At the \$ prompt, type: calterm 148 and press <ENTER>.
 - b. Set up the Function Generator for a +1.00 Vdc output (on the 33120 function generator press and hold offset button for more then 2 seconds then adjust to +1 V), verify voltage with DMM and adjust as needed. When done, press any key on the keyboard to continue calibration.
 - c. The \$ prompt will appear on the screen when the calibration is complete.
 - d. Record step completion on the test record.
2. FM Narrow mode sensitivity calibration is accomplished by adjusting the FM Gain Control DAC to reduce the carrier level as low as possible at frequencies of 5 GHz and 20 GHz. Modulating signal inputs are from the external Function Generator. Perform the calibration as follows:
 - a. At the \$ prompt, type: calterm 125 and press <ENTER>.
 - b. Set up the Function Generator for a 99.8 kHz sine wave. Adjust the Function Generator to produce a DMM (DVM set to ACV) reading of 0.707 volts RMS (2 volts peak to peak) at the FM input.
 - c. On the Spectrum Analyzer, set the frequency initial to 5 GHz with a Span of 500 kHz and adjust the reference level if required.
 - d. On the computer keyboard, use the ```, **1**, **2**, and **3** keys to increment and the **7**, **8**, **9**, and **0** keys to decrement the value of the DAC's setting. Start the calibration by pressing an increment key.
 - e. While observing the first Bessel null ([Figure 4-15 on page 4-30](#)) on the Spectrum Analyzer display, adjust the value of the DAC's setting to reduce the carrier level as low as possible.
 - f. When finished setting the DAC, press **Q** on the keyboard to go to the next calibration step.
 - g. When the DAC has been completely adjusted, the program will exit to the \$ prompt.
 - h. The \$ prompt will appear on the screen when the calibration is complete.
 - i. Record step completion on the test record.

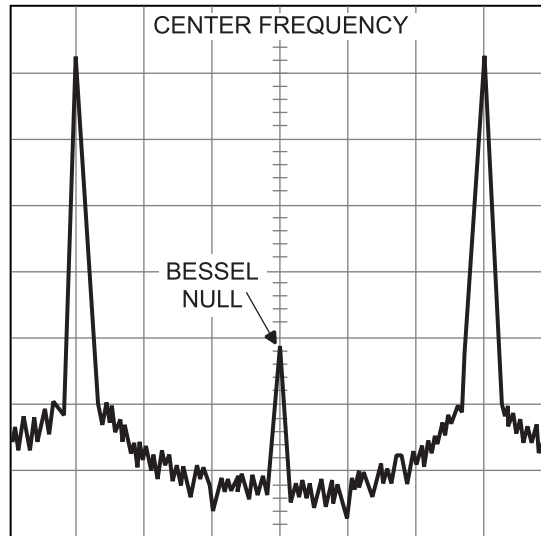

Figure 4-15. Typical Spectrum Analyzer Display of a Bessel Null on an FM Waveform

Note Figure 4-15 is for example only. During the calibrations the above picture is not viewed because the settings on the spectrum analyzer zoom into the Bessel Null's peak.

3. FM Wide mode sensitivity calibration is accomplished by adjusting the FM Gain Control DAC to obtain 200 MHz FM deviations at frequencies of 5 GHz and 15 GHz. Modulating signal inputs are from the external Function Generator. Perform the calibration as follows:
 - a. At the \$ prompt, type: `calterm 124` and press `<ENTER>`.
 - b. Set up the Function Generator for a 0.1 Hz square wave with an output level of 2 volts peak to peak.
 - c. On the Spectrum Analyzer, set the frequency to 5 GHz at a Span of 250 MHz and a RBW of 100 kHz.
 - d. You should now see the frequency jumping from ~5.1 GHz to ~4.9 GHz and it should stay at each frequency for approximately 5 seconds.
 - e. On the computer keyboard, use the ```, `1`, `2`, and `3` keys to increment and the `7`, `8`, `9`, and `0` keys to decrement the value of the DAC's setting.
 - f. While observing the Spectrum Analyzer display, adjust the value of the DAC's setting to obtain a 200 MHz peak to peak deviation. This is the coarse adjustment.
 - g. On the Spectrum Analyzer, set the Span of 50 MHz and adjust the center frequency control to position the low carrier at the center of the display. Note the frequency reading.
 - h. Adjust the center frequency control to position the high carrier at the center of the display. Note the frequency reading.
 - i. The difference between these two frequencies is the actual peak-to-peak frequency deviation. It should be 200 MHz \pm 8 MHz. If not, fine adjust the value of the DAC's setting to obtain this deviation.
 - j. When finished setting the DAC, press `Q` on the keyboard to go to the next calibration step (adjusting the DAC to obtain 200 MHz deviation at a frequency of 15 GHz).
 - k. On the Spectrum Analyzer, set the frequency to 15 GHz at a Span of 250 MHz and a RBW of 100 kHz.

- l. The frequency should jump from ~15.1 GHz to ~14.9 GHz and it should stay at each frequency for approximately 5 seconds.
 - m. While observing the Spectrum Analyzer display, adjust the value of the DAC's setting to obtain a 200 MHz peak to peak deviation. This is the coarse adjustment.
 - n. On the Spectrum Analyzer, set the Span of 50 MHz and adjust the center frequency control to position the low carrier at the center of the display. Note the frequency reading.
 - o. Adjust the center frequency control to position the high carrier at the center of the display. Note the frequency reading.
 - p. The difference between these two frequencies is the actual peak-to-peak frequency deviation. It should be $200 \text{ MHz} \pm 8 \text{ MHz}$. If not, fine adjust the value of the DAC's setting to obtain this deviation.
 - q. When finished setting the DAC, press **Q** on the keyboard to go to the next calibration step (adjusting the DAC to obtain 200 MHz deviation at 15 GHz). When the DAC has been completely adjusted, the program will exit to the \$ prompt.
 - r. The \$ prompt will appear on the screen when the calibration is complete.
 - s. Record step completion on the test record.
4. Φ M External Wide sensitivity calibration is accomplished by adjusting the Φ M gain control DAC to obtain 2.4 and 14.9 RAD/V at frequencies 5 and 20 GHz. Modulation signal inputs are from the external Function Generator. Perform the calibration as follows:
- a. At the \$ prompt, type: calterm 149 and press <ENTER>.
 - b. Set up the Function Generator for a 99.8 kHz sine wave. Adjust the Function Generator to produce a DMM reading of 0.707 volts RMS (2 volts peak to peak) at the FM input.
 - c. On the Spectrum Analyzer, set the frequency initially to 5 GHz at a Span of 0 Hz and 10 Hz RBW.
 - d. On the computer keyboard, use the **`**, **1**, **2**, and **3** keys to increment and the **7**, **8**, **9**, and **0** keys to decrement the value of the DAC's setting. Start calibration by pressing an increment key.
 - e. While observing the first Bessel null ([Figure 4-15](#)) on the Spectrum Analyzer display, adjust the value of the DAC's setting to reduce the carrier level as low as possible.
 - f. When finished setting the DAC, press **Q** on the keyboard to go to the next calibration step.
 - g. When the DAC has been completely adjusted, the program will exit to the \$ prompt.
 - h. The \$ prompt will appear on the screen when the calibration is complete.
 - i. Record step completion on the test record.
5. Φ M External Narrow sensitivity calibration is accomplished by adjusting the Φ M Gain Control DAC to reduce the carrier level as low as possible at frequencies of 5 GHz and 20 GHz. Modulating signal inputs are from the external Function Generator. Perform the calibration as follows:
- a. At the \$ prompt on the PC screen, type: calterm 150 and press <ENTER>.
 - b. Set up the Function Generator for a 99.8 kHz sine wave. Adjust the Function Generator to produce a DMM reading of 0.707 volts RMS (2 volts peak to peak) at the FM input.
 - c. On the Spectrum Analyzer, set the frequency initially to 5 GHz at a Span of 0 Hz and 10 Hz RBW. Press any key to continue.
 - d. On the computer keyboard, use the **`**, **1**, **2**, and **3** keys to increment and the **7**, **8**, **9**, and **0** keys to decrement the value of the DAC's setting. Start calibration by pressing an increment key.
 - e. While observing the first Bessel null ([Figure 4-15](#)) on the Spectrum Analyzer display, adjust the value of the DAC's setting to reduce the carrier level as low as possible.
 - f. When finished setting the DAC, press **Q** on the keyboard to exit the calibration routine.
 - g. The \$ prompt will appear on the screen when the calibration is complete.
 - h. Record step completion on the test record.
6. Perform the Φ M Wide flatness calibration as follows:

- a. At the \$ prompt on the PC screen, type: `calterm 155` and press `<ENTER>`.
 - b. Set up the Function Generator for a 400 Hz sine wave. Adjust the Function Generator to produce a DMM reading of 0.707 volts RMS (2 volts peak to peak) at the FM input.
 - c. On the Spectrum Analyzer, set the frequency initially to 5 GHz at a Span of 0 Hz and 10 Hz RBW. Press any key to continue.
 - d. On the computer keyboard, use the ```, `1`, `2`, and `3` keys to increment and the `7`, `8`, `9`, and `0` keys to decrement the value of the DAC's setting. Start calibration by pressing an increment key.
 - e. While observing the first Bessel null (Figure 4-15) on the Spectrum Analyzer display, adjust the value of the DAC's setting to reduce the carrier level as low as possible.
 - f. When finished setting the DAC, press `Q` on the keyboard to go to the next calibration step.
 - g. When the DAC has been completely adjusted, the program will exit to the \$ prompt.
 - h. Record step completion on the test record.
7. Perform the Φ M Narrow flatness calibration as follows:
- a. At the \$ prompt on the PC screen, type: `calterm 156` and press `<ENTER>`.
 - b. Set up the Function Generator for a 400 Hz sine wave. Adjust the Function Generator to produce a DMM reading of 0.707 volts RMS (2 volts peak to peak) at the FM input.
 - c. On the Spectrum Analyzer, set the frequency initial to 5 GHz at a Span of 0 Hz and 10 Hz RBW. Press any key to continue.
 - d. On the computer keyboard, use the ```, `1`, `2`, and `3` keys to increment and the `7`, `8`, `9`, and `0` keys to decrement the value of the DAC's setting. Start calibration by pressing an increment key.
 - e. While observing the first Bessel null (Figure 4-15) on the Spectrum Analyzer display, adjust the value of the DAC's setting to reduce the carrier level as low as possible.
 - f. When finished setting the DAC, press `Q` on the keyboard to go to exit the calibration routine.
 - g. When the DAC has been completely adjusted, the program will exit to the \$ prompt.
 - h. Record step completion on the test record.
8. Perform the FM Meter calibration as follows:
- a. At the \$ prompt on the PC screen, type: `calterm 123` and press `<ENTER>`.
 - b. Set up the Function Generator for a 100 kHz sine wave. Adjust the Function Generator to produce a DMM reading of 0.707 \pm 0.001 volts RMS (2 volts peak to peak) at the FM input. When done, press any key on the keyboard to continue calibration.
 - c. The \$ prompt will appear on the screen when the calibration is complete.
 - d. Record step completion on the test record.
9. Perform the FM Function Generator Calibration as follows:
- a. Disconnect the cable from the function generator to the FM/ Φ M input.
 - b. At the \$ prompt, type: `calterm 154` and press `<ENTER>`.
 - c. The \$ prompt will appear on the screen when the calibration is complete.
 - d. Record step completion on the test record.
10. Store the calibration data as follows:
- a. At the \$ prompt, type: `calterm 787` and press `<ENTER>`. (The \$ prompt will appear on the screen when the calibration data has been stored.)
 - b. Record step completion on the test record.

Caution

When saving calibration data, turning off the instrument before the \$ prompt returns to the screen can cause all stored data to be lost.

Chapter 5 — Troubleshooting

Note

Troubleshooting procedures presented in this chapter may require the removal of the instrument's covers to gain access to the test points on the printed circuit boards and other subassemblies.

Warning

Hazardous voltages are present inside the MG369xB whenever AC line power is connected. Turn off the instrument and remove the line cord before removing any covers or panels. Troubleshooting or repair procedures should only be performed by service personnel who are fully aware of the potential hazards.

Many subassemblies in the instrument contain static sensitive components. Improper handling of these subassemblies may result in damage to the components. Always observe the static-sensitive component handling precautions.

Caution

ESD Requirements: The MG369xB contains components that can be easily damaged by electrostatic discharge (ESD). An ESD safe work area and proper ESD handling procedures that conform to ANSI/ESD S20.20-1999 or ANSI/ESD S20.20-2007 is mandatory to avoid ESD damage when handling subassemblies or components found in the MG3690B instrument. Repair of damage that is found to be caused by electrostatic discharge is not covered under warranty.

5-1 Introduction

This chapter provides information for troubleshooting the MG369xB. The troubleshooting procedures presented in this chapter support fault isolation to a replaceable subassembly or RF component. Remove and replace procedures for the subassemblies and RF components are found in [Chapter 6, “Removal and Replacement Procedures”](#). Required calibrations after assembly replacement are shown in [Table 4-2 on page 4-5](#).

5-2 Test Equipment List

The test equipment for the troubleshooting procedures presented in this chapter is listed in [Table 1-1 on page 1-6](#).

5-3 Error Messages

During normal operation, the MG369xB generates error messages to indicate internal malfunctions, abnormal instrument operations, or invalid signal inputs or data entries. It also displays warning messages to alert the operator of conditions that could result in inaccurate MG369xB output. In addition, status messages are displayed to remind the operator of current menu selections or settings.

Self-Test Error Messages

The MG369xB firmware includes internal diagnostics that self-test the instrument. These self-test diagnostics perform a brief go/no-go test of most of the instrument PCBs and other internal assemblies.

You can perform an instrument self-test at any time during normal operation by pressing **SYSTEM** and then the system menu soft key, **Self test**.

If the MG369xB fails self-test, error messages are displayed on the front panel data display. These error messages describe the malfunction and, in most cases, provide an indication of what has failed. [Table 5-1](#), on the following page, is a summary listing of the self-test error messages. Included for each is a reference to the troubleshooting table that provides a description of the probable cause and a procedure for identifying the failed component or assembly.

Table 5-1. Self-Test Error Messages (Sheet 1 of 2)

Error Message	Troubleshooting Table	Page Number
Error 100, DVM Ground Offset Failed	Table 5-7	5-13
Error 101, DVM Positive 10V Reference	Table 5-7	5-13
Error 102, DVM Negative 10V Reference	Table 5-7	5-13
Error 107, Sweep Time Clock	Table 5-18	5-18
Error 108, Crystal Oven Cold	Table 5-8	5-14
Error 109, The 100MHz Reference is not Locked to the External Reference	Table 5-9	5-14
Error 110, The 100MHz Reference is not Locked to the High Stability 10 MHz Crystal Oscillator	Table 5-10	5-14
Error 112, Coarse Loop Osc Failed or Coarse Loop B Osc Failed (Option 3 or 30)	Table 5-11 Table 5-12	5-15 5-15
Error 113, YIG Loop Osc Failed	Table 5-15	5-17
Error 114 (Option 5 only), Down Converter LO not Locked	Table 5-16	5-17
Error 115, Not Locked Indicator Failed	Table 5-15	5-17
Error 116, FM Loop Gain Check Failed	Table 5-17	5-18
Error 117, Linearizer Check Failed	Table 5-18	5-18
Error 118, Switch point DAC Failed	Table 5-18	5-18
Error 119, Center Frequency Circuits Failed	Table 5-18	5-18
Error 120, Delta-F Circuits Failed	Table 5-18	5-18
Error 121, Unleveled Indicator Failed	Table 5-19	5-19
Error 122, Level Reference Failed	Table 5-19	5-19
Error 123, Detector Log Amp Failed	Table 5-19	5-19
Error 124, Full Band Unlocked and Unleveled	Table 5-20	5-20
Error 125, 8.4 – 20 GHz Unlocked and Unleveled	Table 5-20	5-20
Error 126, 2 – 8.4 GHz Unlocked and Unleveled	Table 5-20	5-20
Error 127, Detector Input Circuit Failed	Table 5-19	5-19
Error 128, 0.01 – 2 GHz Unleveled or Down Converter Unleveled (Option 4 or 5)	Table 5-22	5-22
Error 129, Switched Filter or Level Detector Failed	Table 5-23	5-25
Error 130, 2 – 3.3 GHz Switched Filter	Table 5-24	5-27
Error 131, 3.3 – 5.5 GHz Switched Filter	Table 5-24	5-27
Error 132, 5.5 – 8.4 GHz Switched Filter	Table 5-24	5-27
Error 133, 8.4 – 13.25 GHz Switched Filter	Table 5-24	5-27
Error 134, 13.25 – 20 GHz Switched Filter	Table 5-24	5-27
Error 135, Modulator or Driver Failed	Table 5-26	5-28
Error 142, Sample and Hold Circuit Failed	Table 5-19	5-19
Error 143, Slope DAC Failed	Table 5-19	5-19

Table 5-1. Self-Test Error Messages (Sheet 2 of 2)

Error Message	Troubleshooting Table	Page Number
Error 144, RF was Off when Self-test started. Some tests were not performed.	Table 5-30	5-30
Error 145, AM Meter or Associated Circuits Failed	Table 5-31	5-30
Error 147, Internal FM Circuits Failed	Table 5-32	5-30
Error 148, Pulse 40 MHz Reference Circuitry Failed	Table 5-33	5-31
Error 149, Coarse Loop C Osc Failed	Table 5-13	5-16
Error 152, Coarse Loop Module Failed	Table 5-13	5-16
MG369xB Models with SDM		
Error 138, SDM Unit or Driver Failed	Table 5-27	5-28
Error 139, 32 – 40 GHz SDM Section Failed	Table 5-28	5-29
Error 140, 25 – 32 GHz SDM Section Failed	Table 5-28	5-29
Error 141, 20 – 25 GHz SDM Section Failed	Table 5-28	5-29
MG369xB Models with SQM		
Error 136, SQM Unit or Driver Failed	Table 5-34	5-32

Normal Operation Error and Warning/Status Messages

When an abnormal condition is detected during operation, the MG369xB displays an error message to indicate that the output is abnormal or that a signal input or data entry is invalid. It also displays warning messages to alert you of conditions that could cause an inaccurate signal generator output. Status messages to remind you of current menu selections or settings are also generated.

[Table 5-2](#) lists possible error messages that may be displayed during normal operations. [Table 5-3](#) is a summary list of possible warning/status messages.

Table 5-2. Possible Error Messages During Normal Operations (Sheet 1 of 2)

Error Message	Description
ERROR	Displayed on the frequency mode title bar when the output frequency is not phase-locked, an invalid frequency parameter entry causes a frequency range error, or an invalid pulse parameter entry causes a pulse modulation error.
LOCK ERROR	Displayed in the frequency parameters area when the output frequency is not phase-locked. The frequency accuracy and stability of the RF output is greatly reduced. This is normally caused by an internal component failure. Run self-test to verify the malfunction.
RANGE	Displayed in the frequency parameters area when the dF value entered results in a sweep outside the range of the instrument, the step size value entered is greater than the sweep range, the number of steps entered results in a step size of less than 0.01 Hz or 0.01 dB (0.001 mV in linear mode), the step sweep time entered divided by the number of steps entered results in a dwell time of <10 ms, or when the analog sweep start frequency entered is greater than the stop frequency. Entering valid values usually clears the error.
SLAVE	Displayed in the frequency parameters area of the Master MG369xB during master-slave operation in VNA mode when the slave frequency offset value entered results in a CW frequency or frequency sweep outside the range of the slave MG369xB. Entering a valid offset value clears the error.

Table 5-2. Possible Error Messages During Normal Operations (Sheet 2 of 2)

Error Message	Description
ERR	<p>Displayed in the modulation status area when one or more of the following error conditions occurs:</p> <p>(1) The external AM modulating signal exceeds the input voltage range. In addition, the message “Reduce AM Input Level” appears at the bottom of the AM status display.</p> <p>(2) The external FM (or FM) modulating signal exceeds the input voltage range. In addition, the message “Reduce FM (or ΦM) Input Level” appears at the bottom of the FM (or ΦM) status display.</p> <p>(3) A pulse parameter setting is invalid for the current pulse modulation state, as follows:</p> <p>Pulse Period: <125 ns (40 MHz clock) or <500 ns (10 MHz clock) longer than pulse widths + delays</p> <p>Single Pulse Mode:</p> <p>Free Run or Gated Trigger: $Width1 > PRI$</p> <p>Delayed Trigger: $Delay1 + Width1 > PRI$</p> <p>Doublet Pulse Mode:</p> <p>Free Run Trigger: $Width1 > Delay2$ or $Width1 + (Delay2 - Width1) + Width2 > PRI$</p> <p>Delayed Trigger: $Width1 > Delay2$ or $Delay1 + Width1 + (Delay2 - Width1) + Width2 > PRI$</p> <p>External Trigger with or without Delay: $Width1 > Delay2$</p> <p>Triplet Pulse Mode:</p> <p>Free Run Trigger: $Width1 > Delay2$ or $Width2 > Delay3$ or $Width1 + (Delay2 - Width1) + Width2 + (Delay3 - Width2) + Width3 > PRI$</p> <p>Delayed Trigger: $Width1 > Delay2$ or $Width2 > Delay3$ or $Delay1 + Width1 + (Delay2 - Width1) + Width2 + (Delay3 - Width2) + Width3 > PRI$</p> <p>External Trigger with or without Delay: $Width1 > Delay2$ or $Width2 > Delay3$</p> <p>Quadruplet Pulse Mode:</p> <p>Free Run Trigger: $Width1 > Delay2$ or $Width2 > Delay3$ or $Width3 > Delay4$ or $Width1 + (Delay2 - Width1) + Width2 + (Delay3 - Width2) + Width3 + (Delay4 - Width3) + Width4 > PRI$</p> <p>Delayed Trigger: $Width1 > Delay2$ or $Width2 > Delay3$ or $Width3 > Delay4$ or $Delay1 + Width1 + (Delay2 - Width1) + Width2 + (Delay3 - Width2) + Width3 + (Delay4 - Width3) + Width4 > PRI$</p> <p>External Trigger with or without Delay: $Width1 > Delay2$ or $Width2 > Delay3$ or $Width3 > Delay4$</p>

Table 5-3. Possible Warning/Status Messages during Normal Operation

Warning/Status Message	Description
COLD	This warning message indicates that the 100 MHz Crystal oven (or the 10 MHz Crystal oven if Option 16 is installed) has not reached operating temperature. Normally displayed during a cold start of the MG369xB. If the message is displayed during normal operation, it could indicate a malfunction. Run self-test to verify.
UNLEVELED	Displayed when the RF output goes unleveled. Normally caused by exceeding the specified leveled-power rating. Reducing the power level usually clears the warning message. If the warning message is displayed only when AM is selected ON, the modulating signal may be driving the RF output unleveled. Reducing the modulating signal or adjusting the power level usually clears the warning.
UNLOCKED	When Unlocked/Narrow FM or Unlocked/Wide FM is selected ON, this warning message appears indicating that the instrument is not phase-locked during this FM mode of operation.
REDUCE RATE	This warning message is displayed when the AM rate, FM rate, or Phase Modulation rate is set >100 kHz for a non-sine wave modulating waveform. Amplitude, frequency, or phase modulation of the output signal will continue but the modulating waveform may be distorted.
SLOPE	This status message indicates that a power slope correction has been applied to the ALC.
EXTL REF	This status message indicates that an external 10 MHz signal is being used as the reference signal for the MG369xB.
OFFSET	This status message indicates that a constant (offset) has been applied to the displayed power level.
CW RAMP	This status message appears on all CW menu displays to indicate that the CW ramp has been turned on.
USER 1...5	This status message indicates that a user level flatness correction power-offset table has been applied to the ALC.

5-4 No Error Message

The MG369xB must be operating to run self-test. Therefore, malfunctions that cause the instrument to be non-operational do not produce error messages. These problems are generally a failure of the MG369xB to power up properly. [Table 5-4](#), beginning on [page 5-11](#), provides troubleshooting procedures for these malfunctions.

5-5 Troubleshooting Tables

Table 5-4 through Table 5-34, beginning on page 5-11, provide procedures for isolating malfunctions displaying self-test errors to a replaceable subassembly or RF component. In those cases where any of several subassemblies or RF components could have caused the problem, subassembly/RF component replacement is indicated. The recommended replacement order is to replace first the subassemblies/RF components that are most likely to have failed.

Figure 5-1 through Figure 5-5, on the following pages, show the location of the MG369xB connectors and test points that are called out in the troubleshooting procedures of Table 5-4 through Table 5-34.

Caution Never remove or replace a subassembly or RF component with power applied. Always remove the power cord before disassembly and removal of any component or PCB. Serious damage to the instrument or personal injury may occur.

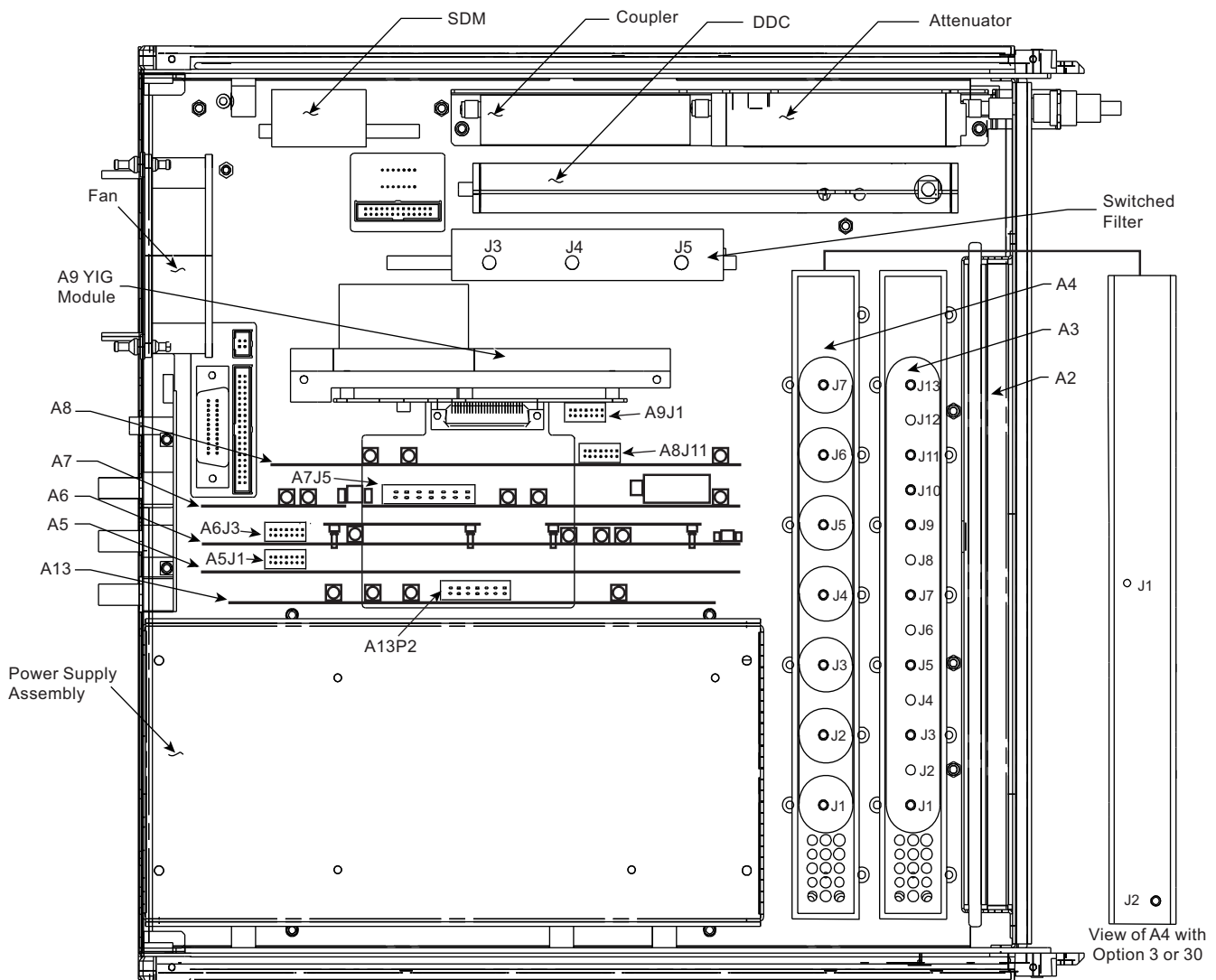

Figure 5-1. Top View of the MG369xB Showing Connector and Test Point Locations

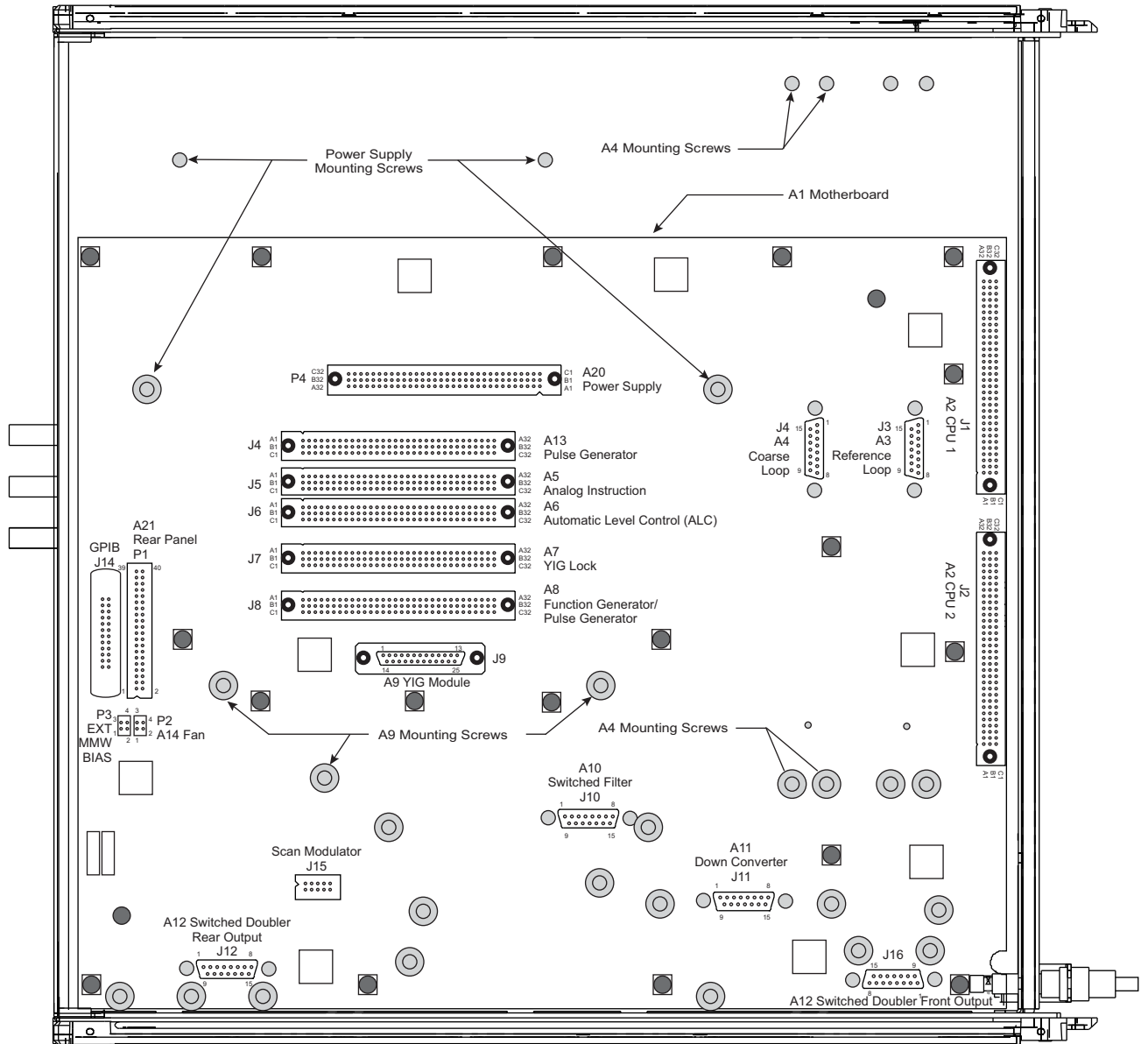

Figure 5-2. Bottom View of the MG369xB Showing Connector and Test Point Locations

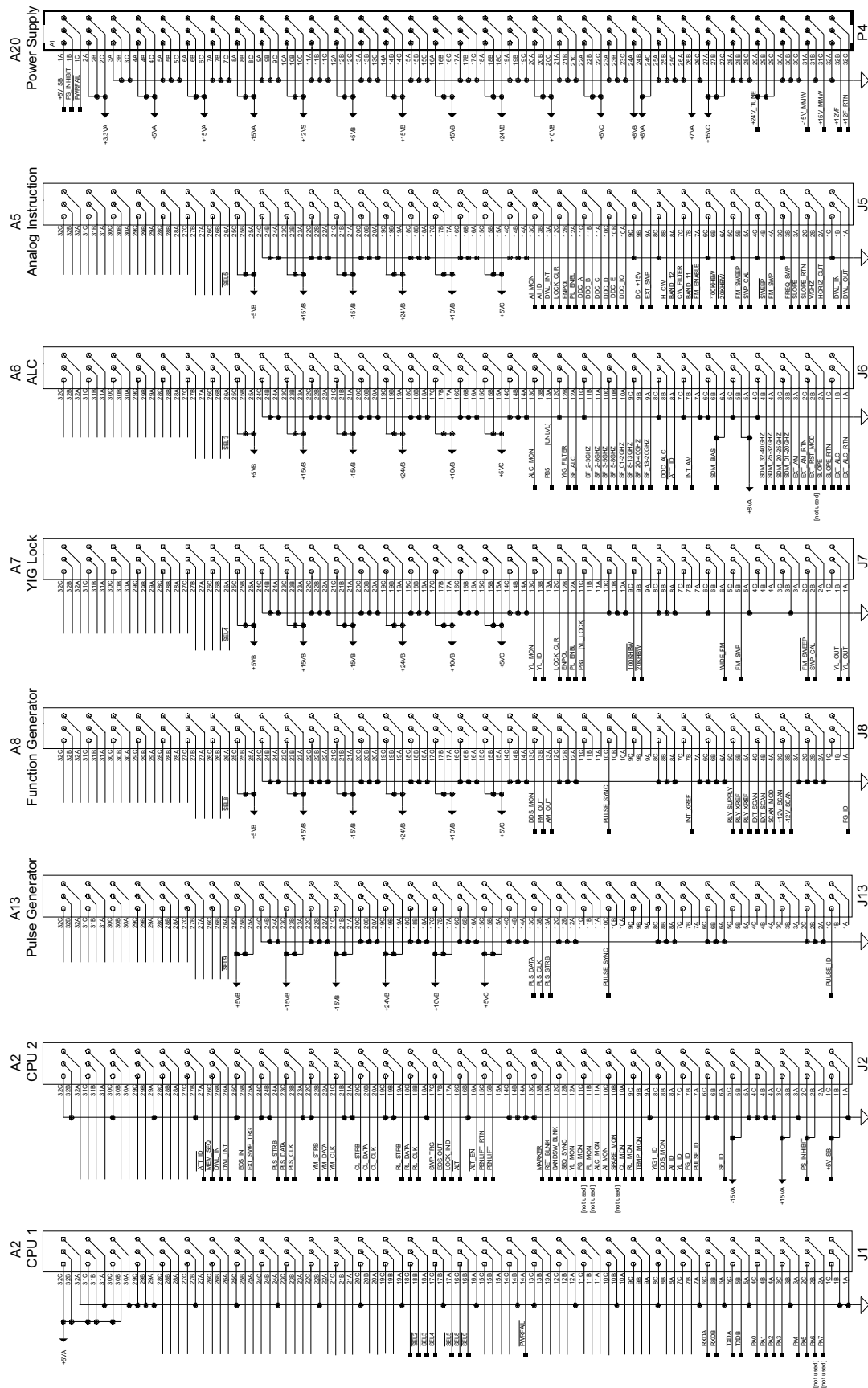

Figure 5-3. Motherboard Connector Pinout Diagram (1 of 2)

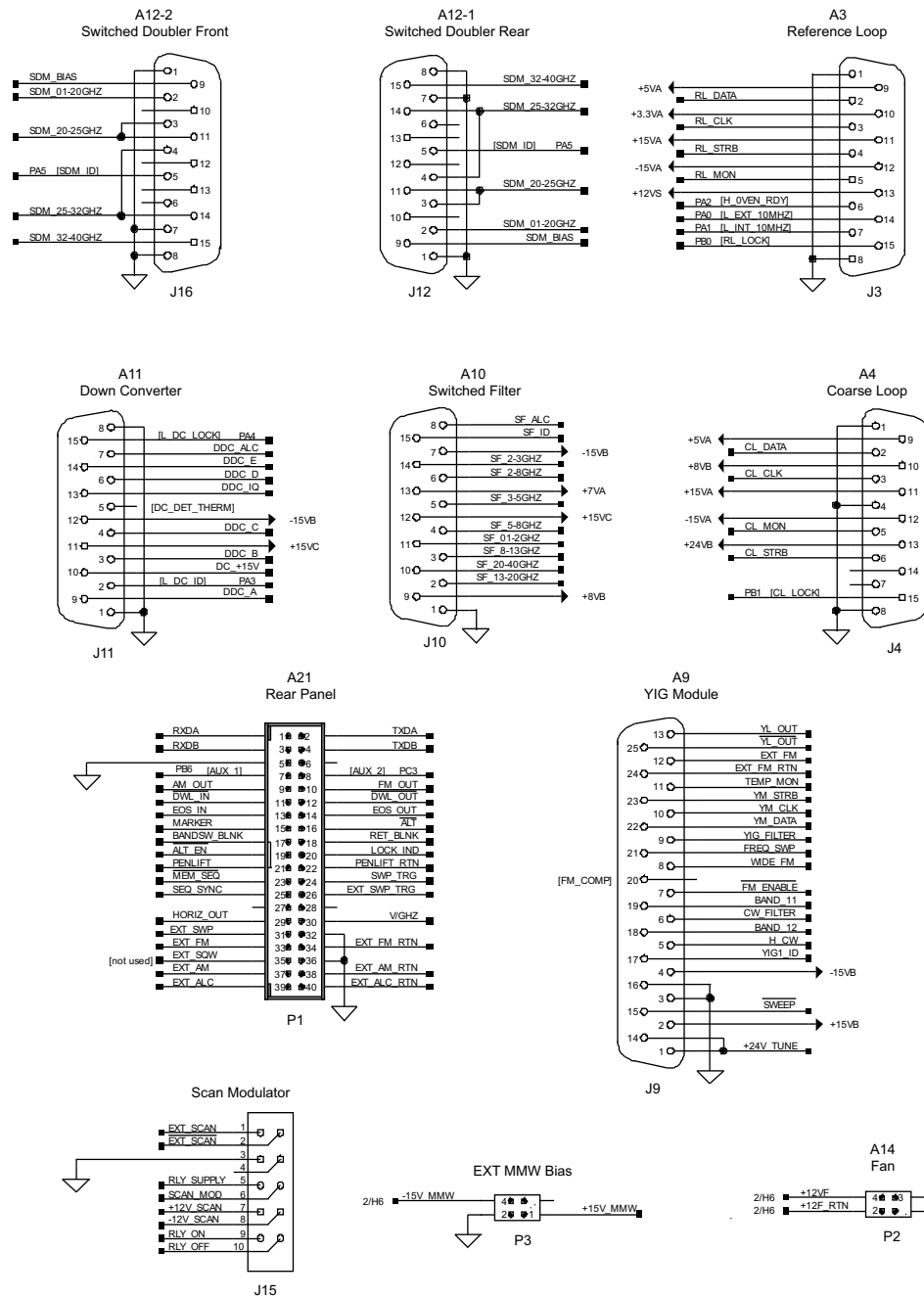

Figure 5-4. Motherboard Connector Pinout Diagrams (2 of 2)

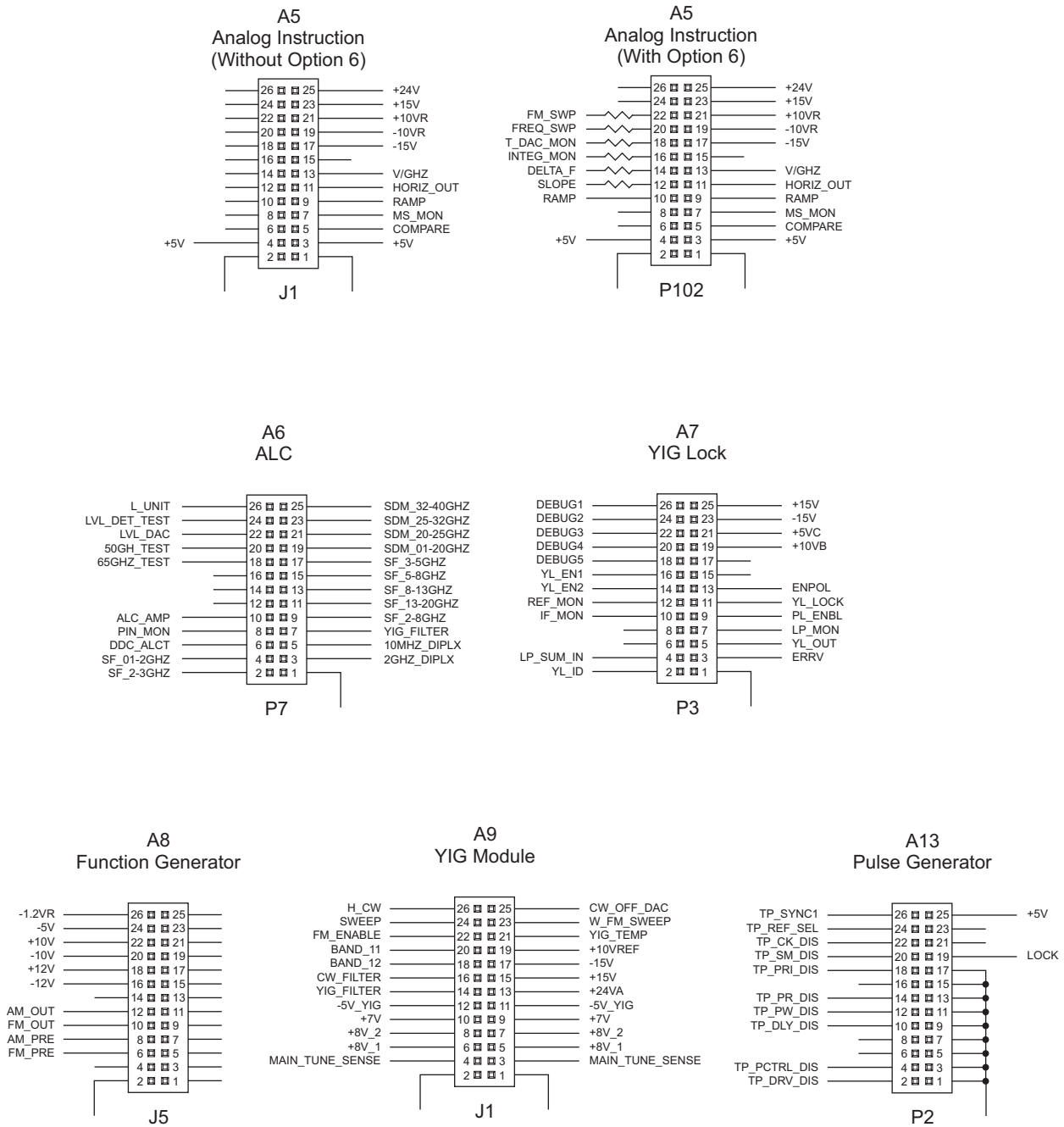

Figure 5-5. PCB Test Point Pinout Diagrams

Table 5-4. Malfunctions Not Displaying an Error Message**MG369xB Will Not Turn On (OPERATE light and FAN are OFF)**

Normal Operation: When the MG369xB is connected to the power source and the rear panel line switch is turned on, the OPERATE light should illuminate and the instrument should power up. When the MG369xB is set to standby mode, the fans should run slow and the STANDBY light should illuminate.

1. Disconnect the MG369xB from the power source, then check the line fuses on the rear panel.
 - If the line fuses are good, go to step 2.
 - If the line fuses are defective, replace the fuses.
2. Apply power to the instrument.
 - If the instrument powers up, the problem is cleared.
 - If the instrument fails to power up, go to step 3.
3. Disconnect the MG369xB from the power source, then remove the MG369xB top cover and the cover located over the A5-A9 PCBs.
4. Remove the four outer screws to the top cover of the power supply module and lift the cover with the main power supply attached. Refer to the R&R procedures in [Chapter 6, “Removal and Replacement Procedures”](#) as needed.
5. Inspect the ac line supply/switch block and the wiring to the main power supply and standby power supply for defects.
 - If a defect is found, replace as necessary.
 - If no defect is found, go to step 6.
6. Replace the standby and main power supplies.
 - If the instrument powers up, the problem is cleared.
 - If the instrument fails to power up, contact your local Anritsu service center for assistance.

Table 5-5. Malfunctions Not Displaying an Error Message**MG369xB Will Not Turn On (OPERATE light is ON)**

Normal Operation: When the MG369xB is connected to the power source and the rear panel line switch is turned on, the OPERATE light should illuminate and the instrument should power up. When the MG369xB is set to standby mode, the fans should run slow and the STANDBY light should illuminate.

1. Remove the MG369xB top and bottom cover and the cover located over the A5-A9 PCBs.
2. Apply power and measure the regulated voltages at A1P4 per [Table 5-6](#) on the following page.
 - If one or more, but not all of the related voltages are out of regulation, a malfunction of the regulation circuitry is indicated. Replace the A20 voltage regulator PCB.
 - If all of the related voltages are out of regulation, a malfunction of the regulator supply source is indicated. Replace the related supply source as shown in [Table 5-6](#).
3. Check for normal operation.
 - If the instrument powers up, the problem is cleared.
 - If the instrument fails to power up, go to step 4.
4. Press the front panel **RF OUTPUT ON/OFF** button.
 - If the red and yellow LEDs toggle, the malfunction may be caused by a failed front panel circuit. Replace the front panel assembly.
 - If the LEDs do not toggle or if both LEDs are lit, the problem may be caused by a CPU malfunction. Replace the A2 PCB.

5. Check for normal operation.

- If the instrument powers up, the problem is cleared.
- If the instrument fails to power up, contact your local Anritsu service center for assistance.

Table 5-6. Power Supply Module Regulated Outputs

A1P4 Pin #	Regulator Output (V)	Related Source
10A	+12	Standby Power Supplies
32B	+12 ^a	
1A	+5	
18A	+24	Main Power Supplies (Positive V)
29A	+24	
6A	+15	
14A	+15	
27A	+15	
31C	+15	
20A	+10	
24A	+8	
24B	+8	
26B	+7	
4A	+5	
12A	+5	
22A	+5	
2A	+3.3	
8B	-15	Main Power Supply (Negative V)
16A	-15	
31A	-15	

a. This value is approximately +6.78 V while the unit is in standby.

Table 5-7. Error Messages 100, 101 and 102**Internal DVM Tests****Error 100 DVM Ground Offset Failed, or
Error 101 DVM Positive 10V Reference, or
Error 102 DVM Negative 10V Reference**

Description: The DVM circuitry, located on the A2 CPU PCB, is calibrated using the ± 10 volts from the reference supplies on the A5 auxiliary PCB. The error messages indicate a calibration-related problem or a defective ± 10 volt reference.

1. Perform a manual pre-calibration (Refer to [Chapter 4-7, “Preliminary Calibration”](#)).
2. Run self-test.
 - If no error message is displayed, the problem is cleared.
 - If any of the error messages, 100, 101, and 102, are displayed, go to step 3.
3. Connect the negative lead of the digital multimeter to A5J1 pin 1.
4. Measure the ± 10 V reference voltages at A5J1* pin 19 and A5J1* pin 21. A5J1* pin 19 should be $-10\text{V} \pm 0.036\text{V}$; A5J1* pin 21 should be $+10\text{V} \pm 0.036\text{V}$.
 - *If the A5 PCB is part number 52225-3, measure the voltages at A5P102.
 - If the ± 10 V reference voltages are correct, go to step 5.
 - If incorrect, replace the A5 PCB and perform a manual pre-calibration.

Note

Even if the ± 10 V reference voltages are correct, there could still be a malfunction of the DVM multiplexer on the A5 PCB or the DVM circuitry on the A2 CPU PCB.

5. Replace the A5 PCB, perform a manual pre-calibration and run self-test again.
 - If no error message is displayed, the problem is cleared.
 - If any of the error messages, 100, 101, and 102, are displayed, go to step 6.
6. Replace the A2 PCB, perform a manual pre-calibration and run self-test.
 - If no error message is displayed, the problem is cleared.
 - If any of the error messages, 100, 101, and 102, are displayed, contact your local Anritsu service center for assistance.

Table 5-8. Error Message 108

A3 Reference/Fine Loop**Error 108 Crystal Oven Cold**

Description: The oven of the 100 MHz and 10 MHz crystal oscillator has not reached operating temperature.

1. Allow a 30 minute warm up, then run self-test.
 - If error 108 is not displayed, the problem is cleared.
 - If error 108 displays, go to step 2.
2. Replace the A3 PCB. Allow a 30 minute warm up, then run self-test.
 - If error 108 is not displayed, the problem is cleared.
 - If error 108 displays, go to step 3.
3. Replace the A2 PCB. Allow a 30 minute warm up, then run self-test.
 - If error 108 is not displayed, the problem is cleared.
 - If error 108 is displayed, contact your local Anritsu service center for assistance.

Table 5-9. Error Message 109

Error 109 The 100 MHz Reference is not phase-locked to the External Reference

Description: The reference loop is not phase-locked to the external 10 MHz reference.

1. Using a coaxial cable with BNC connectors, connect the rear panel 10 MHz REF IN connector to the rear panel 10 MHz REF OUT connector.
2. Disconnect the MCX cable W158 from A3J13.
3. Using an oscilloscope, verify the presence of a 10 MHz signal at the end of the MCX cable W158. The signal amplitude should be > 0.5 volts peak-to-peak (into 50 Ω).
 - If present, replace the A3 PCB.
 - If not present, replace the MCX cable W158.

Table 5-10. Error Message 110

Error 110 The 100 MHz Reference is not Locked to the High Stability 10 MHz Crystal Oscillator

Description: The reference loop is not phase-locked to the optional, high stability 10 MHz crystal oscillator.

1. Replace the A3 PCB.
 - If error 110 is not displayed, the problem is cleared.
 - If error 110 is displayed, go to step 2.
2. Replace the A2 PCB.
 - If error 110 is not displayed, the problem is cleared.
 - If error 110 is displayed, contact your local Anritsu service center for assistance.

Table 5-11. Error Message 112

A4 Coarse Loop

Error 112 Coarse Loop Osc Failed (models without Option 3 or 30)

Description: The coarse loop oscillator is not phase-locked.

1. Disconnect the MCX cable W151 at A4J1 and the MCX cable W188 at A4J7.
2. Using a Spectrum Analyzer, verify the presence of a +7 dBm \pm 4 dB, 500 MHz signal at the end of the MCX cable W151 from A4J1 and a 3 dBm \pm 3 dB, 100 MHz signal at the end of the MCX cable W188 from A4J7.
 - Reconnect the MCX cables. If present, go to step 5.
 - If one or both of the signals are not present, go to step 3.
3. Disconnect the MCX cable W151 at A3J3 and the MCX cable W188 at A3J7.
4. Using the Spectrum Analyzer, verify the presence of a +7 dBm \pm 4 dB, 500 MHz signal at A3J3 and a 3 dBm \pm 3 dB, 100 MHz signal at A3J7.
 - If the 500 MHz signal is present, replace the MCX cable W151.
 - If the 100 MHz signal is present, replace the MCX cable W188.
 - If either signal is not present, replace the A3 PCB.
5. Reconnect the MCX cables to A3J3 and A3J7, then disconnect the MCX cable W158 at A4J3.
6. Set up the MG369xB to generate the CW frequencies listed in [Table 5-12](#).

Table 5-12. Coarse Loop Frequencies

MG369xB CW Frequency	Measured Frequency at A4J3
2.000 GHz (Skip if option 4 installed)	219.5 MHz \pm 10 kHz
2.050 GHz (Skip if option 4 installed)	225.0 MHz \pm 10 kHz
2.225 GHz	244.5 MHz \pm 10 kHz

7. Using a Spectrum Analyzer, measure the frequency and amplitude of the signal at A4J3 for each of the CW frequencies generated. In each case, the signal amplitude should be +4 dBm \pm 6 dB with sidebands at $<$ -50 dBc.
 - If the signals are correct in both frequency and amplitude, go to step 8.
 - If the signals are incorrect, replace the A4 PCB.
8. Reconnect the MCX cable W158 to A4J3 and run self-test again.
 - If error 112 is not displayed, the problem is cleared.
 - If error 112 is still displayed, contact your local Anritsu service center for assistance.

Table 5-13. Error Messages 112, 149, 152

Error 112 Coarse Loop B Osc Failed (models with Option 3 or 30)

Error 149 Coarse Loop C Osc Failed

Error 152 Coarse Loop Module Failed

Description: One of the oscillators within the coarse loop is not phase-locked.

1. Disconnect the MCX cable W153 at A4J1.
2. Using a Spectrum Analyzer, verify the presence of a +3 dBm \pm 3 dB, 100 MHz signal at the end of the MCX cable W153.
 - If present, go to step 5.
 - If not present, go to step 3.
3. Disconnect the MCX cable W153 at A3J7.
4. Using the Spectrum Analyzer, verify the presence of the +3 dBm \pm 3 dB, 100 MHz signal at A3J7.
 - If present, replace the MCX cable W153.
 - If not present, replace the A3 PCB.
5. Reconnect the MCX cable W153 to A4J1, then disconnect the MCX cable W157 at A4J2.
6. Set up the MG369xB to generate the CW frequencies listed in [Table 5-14](#).

Table 5-14. Coarse Loop Frequencies

MG369xB CW Frequency	Measured Frequency at A4J2
2.215 GHz	205.0 MHz \pm 10 kHz
4.335 GHz	437.5 MHz \pm 10 kHz
13.190 GHz	945.0 MHz \pm 10 kHz

7. Using a Spectrum Analyzer, measure the frequency and amplitude of the signal at A4J2 for each of the CW frequencies generated. In each case, the signal amplitude should be 0 dBm \pm 6 dB with sidebands at $<$ -65 dBc.
 - If the signals are correct in both frequency and amplitude, go to step 8.
 - If the signals are incorrect, replace the A4 PCB.
8. Reconnect the MCX cable W157 to A4J2 and run self-test again.
 - If error 112, 149 or 152 is not displayed, the problem is cleared.
 - If error 112, 149 or 152 is still displayed, contact your local Anritsu service center for assistance.

Table 5-15. Error Messages 113 and 115**A7 YIG Loop****Error 113 YIG Loop Osc Failed****Error 115 Not Locked Indicator Failed**

Description: Error 113 indicates that the YIG loop is not phase-locked. Error 115 indicates a failure of the not phased-locked indicator circuit.

1. Perform an initial calibration of the 10 MHz reference oscillator (calterm 130) per the procedure in Step 2 of [Table 5-10 on page 5-14](#)
 - If error 113 or 115 is not displayed, the problem is cleared.
 - If error 113 or 115 is displayed, go to [Step 2](#) below.
2. Verify the signal output from the A4 coarse loop PCB (for units without option 3 or 30) by performing [Step 5](#) through [Step 7](#) in [Table 5-11 on page 5-15](#) or verify the signal output from the A4 coarse loop PCB (for units with option 3 or 30) by performing [Step 5](#) through [Step 7](#) in [Table 5-13 on page 5-16](#).
 - If the coarse loop signals are correct in both frequency and amplitude, go to [Step 3](#).
 - If the coarse loop signals are incorrect, replace the A4 PCB.
3. Verify the signal output from the A3 reference loop PCB (for units without option 3 or 30) by performing [Step 1](#) thru [Step 4](#) in [Table 5-11](#) or verify the signal output from the A3 reference loop PCB (for units with option 3 or 30) by performing [Step 1](#) thru [Step 4](#) in [Table 5-13](#).
 - If the reference loop signals are correct in both frequency and amplitude, go to [Step 4](#).
 - If the reference loop signals are incorrect, replace the A3 PCB.
4. Disconnect the semi-rigid cable at the output port J5 of the switched filter assembly.
5. Set up the MG369xB to generate a CW frequency of 2.000 GHz (for units with option 4 set to 3 GHz).
6. Using a Spectrum Analyzer, measure the frequency and amplitude of the signal at J5 of the switched filter assembly. The frequency should be 2.000 GHz \pm 25 MHz (for units with option 4 set to 3 GHz) and the amplitude should be from -7 to -14 dBm.
 - If the signal is correct in both frequency and amplitude, go to step 6.
 - If the signals are incorrect, replace the switched filter assembly.
7. Repeat steps 4 and 5, incrementing the CW frequency in 1 GHz steps up to 20.000 GHz.
8. If the signals from the coarse loop, reference loop, and switched filter assembly are all correct, replace the A7 YIG loop PCB.
9. Run self-test.
 - If error 113 or 115 are not displayed, the problem is cleared.
 - If either error 113 or 115 are displayed, contact your local Anritsu service center for assistance.

Table 5-16. Error Message 114**A11 Down Converter****Error 114 Down Converter LO not Locked (Option 5 only)**

Description: The local oscillator in the down converter assembly is not phase-locked.

1. Disconnect the MCX cable W152 at A3J5.
2. Using a Spectrum Analyzer, verify the presence of a +7 dBm \pm 4 dB, 500 MHz signal at A3J5.
 - If present, go to step 3.

- If not present, replace the A3 PCB.
3. Reconnect the MCX cable W152 to A3J5, then disconnect the MCX cable W152 at J2 of the down converter assembly.
 4. Using a Spectrum Analyzer, verify the presence of a +7 dBm \pm 4 dB, 500 MHz signal at the end of the MCX cable W152.
 - If present, replace the down converter assembly.
 - If not present, replace the MCX cable W152.

Table 5-17. Error Message 116

A7A1 FM PCB**Error 116 FM Loop Gain Check Failed**

Description: The FM loop has failed or the loop gain is out of tolerance.

1. Perform a preliminary calibration (Refer to [Chapter 4, “Adjustment”](#)).
2. Run self-test.
 - If error 116 is not displayed, the problem is cleared.
 - If error 116 is still displayed, go to step 3.
3. Replace the A7A1 PCB and run self-test again.
 - If error 116 is not displayed, the problem is cleared.
 - If error 116 is displayed, contact your local Anritsu service center.

Table 5-18. Error Messages 107, 117, 118, 119, and 120

A5 Analog Instruction PCB**Error 107 Sweep Time Check Failed****Error 117 Linearizer Check Failed****Error 118 Switch point DAC Failed****Error 119 Center Frequency Circuits Failed****Error 120 Delta-F Circuits Failed**

Description: Each of these error messages indicates a problem in the circuitry on the A5 Analog Instruction PCB or the A9 YIG module that provides frequency tuning voltages for the YIG-tuned oscillator.

1. Perform a preliminary calibration (Refer to [Chapter 4, “Adjustment”](#)).
2. Run self-test.
 - If no error message is displayed, the problem is cleared.
 - If error 107, 117, 118, or 120 is displayed, replace the A5 auxiliary PCB.
 - If error 119 is displayed, replace the A9 YIG module.
3. Perform a preliminary calibration and run self-test again.
 - If no error message is displayed, the problem is cleared.
 - If any of the error messages, listed above, is displayed, contact your local Anritsu service center for assistance.

Table 5-19. Error Messages 121, 122, 123, 127, 142, and 143**A6 ALC****Error 121 Unleveled Indicator Failed****Error 122 Level Reference Failed****Error 123 Detector Log Amp Failed****Error 127 Detector Input Circuit Failed****Error 142 Sample and Hold Circuit Failed****Error 143 Slope DAC Failed**

Description: Error 121 indicates a failure of the circuit that alerts the CPU whenever the RF output power becomes unleveled. Each of the other error messages indicate a problem in the circuitry on the A6 ALC PCB that provides control of the RF output power level.

1. Replace the A6 PCB, and run self-test.
 - If no error message is displayed, the problem is cleared.
 - If error message 121, 122, 123, 127, or 142 is displayed, contact your local Anritsu service center for assistance.
 - If error message 143 is displayed, proceed to step 2.
2. Calibrate the ALC slope (Refer to [Chapter 4, “Adjustment”](#)).
3. Run self-test.
 - If error 143 is not displayed, the problem is cleared.
 - If error 143 is still displayed, go to step 4.
4. Replace the A6 PCB and run self-test again.
 - If error 143 is not displayed, the problem is cleared.
 - If error 143 is still displayed, go to step 5.
5. Replace the A5 PCB and run self-test again.
 - If error 143 is not displayed, the problem is cleared.
 - If error 143 is still displayed, contact your local Anritsu service center for assistance.

Table 5-20. Error Messages 124, 125 and 126

A9 YIG-tuned Oscillator Module**Error 124 Full Band Unlocked and Unleveled****Error 125 8.4-20 GHz Unlocked and Unleveled****Error 126 2-8.4 GHz Unlocked and Unleveled****Description:** These error messages indicate a failure of the YIG-tuned oscillator module.

Model MG369xB YIG-tuned Oscillator Failure

1. Connect a 56100A scalar network analyzer to the MG369xB as follows:
 - a. Connect the MG369xB AUX I/O to the 56100A AUX I/O.
 - b. Connect the 56100A DEDICATED GPIB to the MG369xB IEEE-488 GPIB.
 - c. Connect the RF detector to the 56100A Channel A input.
2. Set up the MG369xB as follows:
 - a. Frequency: Step Sweep
 - b. F1: 2.000 GHz (2.21 GHz with Option 4)
 - c. F2: 20.000 GHz
 - d. More: Number of Steps: 400
3. Set up the 56100A Scalar Network Analyzer as follows:
 - a. Press the **SYSTEM MENU** key.
 - b. From System menu display, select **RESET**.
 - c. Press **CHANNEL 2 DISPLAY: OFF**
 - d. Press **CHANNEL 1 DISPLAY: ON**
 - e. Press the **CHANNEL 1 MENU** key.
 - f. From the Channel 1 menu display, select **POWER**.
4. Using the scalar network analyzer, measure the RF output directly at the YIG-tuned oscillator's output connector. The amplitude of the RF signal should be >4 dBm throughout the full sweep.
 - If the RF signal is correct in both frequency and amplitude throughout the full sweep, go to step 9.
 - If there is no RF signal for all or part of the sweep or if the amplitude of the RF signal is low, go to step 5.
5. Using the oscilloscope, check for the YIG module power supply voltages shown in [Table 5-21](#) on the next page.
 - If the voltages are correct, go to step 6.
 - If the voltages are incorrect, refer to the troubleshooting [Table 5-6](#) to determine if the power supply or regulator PCB needs to be replaced.
6. Connect the X input of an oscilloscope to the MG369xB rear panel **HORIZ OUT** connector.
7. Using the oscilloscope, check A9J1 pin 21 for approximately –0.0 V to –8 V YIG tuning ramp. The sweep from 2 to 20 GHz will be in two ramps; one for 2 GHz to 10 GHz which starts at 0 V and goes to –6 V; the other is for 10 GHz to 20 GHz which goes from 0 V to –8 V.
 - If the ramp signal is correct, go to step 8.
 - If the ramp signal is incorrect or not present, replace the A9 YIG module assembly.
8. Using the oscilloscope, check for the YIG-tuned oscillator bias voltages at the test points shown in [Table 5-21](#).

- If the YIG-tuned oscillator bias voltages are correct, replace the A9 YIG module assembly.
 - If the YIG bias voltages are incorrect, go to step 9.
9. Perform the preliminary calibration in [Section 4-7](#), then run self-test again.
- If no error message is displayed, the problem is cleared.
 - If any of the error messages, listed above, are displayed, contact your local Anritsu service center for assistance.

Table 5-21. YIG Module Assembly Bias Voltages

Test Point	YIG Module Power Supply Bias Voltages	
A1J9 pin 1	+24 volts	
A1J9 pin 2	+15 volts	
A1J9 pin 4	-15 volts	
YIG-tuned Oscillator Bias Voltages		
Test Point	Pin	Description and Voltage
A1J9	19	Band 11 (2 GHz to 10 GHz enabled High) ~ +5 V when frequency is in band, ~ 0 V out of band
A1J9	18	Band 12 (10 GHz to 20 GHz enabled High) ~ +5 V when frequency is in band, ~ 0 V out of band

Table 5-22. Error Message 128

Output Power Level Related Problems (0.01 to 20 GHz)**Error 128 0.01-2 GHz Unleveled or Down Converter Unleveled (Option 4)**

Description: Error 128 indicates a failure of the down converter leveling circuitry. The MG369xB may or may not produce an RF output in the 0.01 to 2 GHz frequency range. Thus, there are two troubleshooting paths for this problem-unleveled with output power and unleveled with no/low output power.

Unleveled with Output Power: The warning message UNLEVELED appears on the front panel display. There are two testing methods depending on test equipment availability:

Method 1: Uses a power meter and power sensor.

Method 2: Uses a microwave detector.

1. Set up the MG369xB as follows:
 - a. Frequency: Step Sweep
 - b. F1: 0.01 GHz
 - c. F2: 2.000 GHz (2.2 GHz with Option 4)
 - d. More: Number of Steps: 400
 - e. Previous: L1: +1.00 dBm
 - f. Level: ALC Mode: Leveling
 - g. Depending on the testing method press:
 - Power Meter for Method 1
 - External Detector for Method 2

Method 1: Using a power meter

1. Connect a power sensor (MA2474 for K connectors or MA2475 for V connectors) to the power meter (ML2438).
2. Connect the power sensor to the calibrator output on the ML2438 using an proper N to K or V adapter,
3. Set up the power meter as follows:
 - a. Press the Cal/Zero key
 - b. Press Zero/cal to calibrate the power sensor.
 - c. Press the System key
 - d. Press More twice.
 - e. Press Rear Panel
 - f. Press BNC
 - g. Press Mode until Operating Mode reads Chan Leveling A(1).
4. Connect the power sensor to the MG369xB RF OUTPUT connector.
5. Connect a BNC cable to Output 1 of the rear panel of the MA2438x.
6. Connect the other end of the BNC cable to EXT ALC IN of the rear panel of the MG369xB.
7. Measure with the power meter.
 - a. Press the Sensor key of the power meter.

- b. The power meter should read about +1 dBm.

Note The value will not be stable because the synthesizer is sweeping the frequency from 10 MHz to 2 GHz or 2.2 GHz.

8. On the MG369xB

- a. Press Level: ALC Mode
- b. Press Leveling
- c. Press Power Meter
- d. Press the Level Key (note the L1 readout is 3400 which is the DAC value for the ALC).
- e. While watching the power meter, adjust the DAC value to about 7200 or until the power meter reads about +10 dBm.
 - If the warning message UNLEVEDED no longer appears on the front panel display, replace the down converter.
 - If the warning message UNLEVELED is still displayed, replace the A6 PCB.

Method 2: Using a microwave detector.

1. Connect a microwave detector (Anritsu part number 75KC50 for K connector units or 75VA50 for V connectors) to the MG369xB RF OUTPUT connector.
2. Connect the output of the microwave detector to the rear panel EXTERNAL ALC IN connector.
3. Measure with the MG369xB:
 - a. Press Level: ALC Mode
 - b. Press Leveling then press External Microwave Detector
 - If the warning message UNLEVEDED no longer appears on the front panel display, replace the down converter.
 - If the warning message UNLEVELED is still displayed, replace the A6 PCB.

Unleveled with No/Low Output Power:

1. Set up the MG369xB as follows:
 - a. Frequency: Step Sweep
 - b. F1: 0.010 GHz
 - c. F2: 2.000 GHz (2.2 GHz with Option 4)
 - d. More: Number of Steps: 400
 - e. Previous: L1: +1.00 dBm
 - f. Level: ALC Mode: Leveling
 - g. Leveling: External Detector
2. Connect the X input of an oscilloscope to the MG369xB rear panel HORIZ OUT connector.
3. Using the oscilloscope, check at the end of the MCX cable W160 that is connected to A6J2 for a > 2.0 volt down converter detector output throughout the full sweep.
 - If the detector voltage is correct, replace the A6 PCB.
 - If the detector voltage is incorrect, go to step 4.
4. Using the oscilloscope, check for a +15 volt down converter bias voltage at A1J11 pin 10.
 - If the bias voltage is correct, go to step 5.
 - If the bias voltage is not correct, replace the A5 PCB.

5. Using the oscilloscope, check for a –2 volt PIN switch drive voltage at A1J10 pin 11. If the MG369xB has a SDM installed, also check for a +20 volt PIN switch drive voltage at A1J6 pin 3B.
 - If the PIN switch drive voltages are correct, go to step 6.
 - If the PIN switch drive voltages are not correct, replace the A6.
6. Connect a 56100A scalar network analyzer to the MG369xB as follows:
 - a. Connect the MG369xB AUX I/O to the 56100A AUX I/O.
 - b. Connect the 56100A DEDICATED GPIB to the MG369xB IEEE-488 GPIB.
 - c. Connect the RF detector to the 56100A Channel A input.
7. Set up the 56100A scalar network analyzer as follows:
 - a. Press the **SYSTEM MENU** key.
 - b. From the System menu display, select **RESET**.
 - c. Press **CHANNEL 2 DISPLAY: OFF**
 - d. Press **CHANNEL 1 DISPLAY: ON**
 - e. Press the **CHANNEL 1 MENU** key.
 - f. From the Channel 1 menu display, select **POWER**.
8. Using the scalar network analyzer with a 10 dB pad, measure the RF output at J3 of the switched filter assembly. The amplitude of the RF signal should be > +17 dBm throughout the full sweep.
 - If the amplitude of the RF signal is correct, replace the down converter assembly.
 - If there is no RF signal or if the amplitude of the RF signal is low, replace the switched filter assembly.
9. Run self-test again.
 - If no error message is displayed, the problem is cleared.
 - If any of the error messages, listed above, are displayed, contact your local Anritsu service center for assistance.

Table 5-23. Error Message 129**Error 129 Switched Filter or Level Detector Failed**

Description: Error 129 indicates a failure of either the switched filter or level detector circuitry. The MG369xB may or may not produce an RF output in the 2 to 20 GHz frequency range. Thus, there are two troubleshooting paths for this problem—unleveled with output power and unleveled with no/low output power.

Unleveled with Output Power: The warning message UNLEVELED appears on the front panel display):

1. Set up the MG369xB as follows:
 - a. Frequency: Step Sweep
 - b. F1: 2.000 GHz (2.21 GHz with Option 4)
 - c. F2: 20.000 GHz
 - d. More: Number of Steps: 400
 - e. Previous: L1: +1.00 dBm
 - f. Level: ALC Mode: Leveling
 - g. Leveling: External Detector
2. Connect a detector to the MG369xB RF OUTPUT connector and connect the detected DC output of the detector to the rear panel EXTERNAL ALC IN connector.
 - If the warning message UNLEVELED no longer appears on the front panel display, replace the directional coupler.
 - If the warning message UNLEVELED is still displayed, replace the A6 PCB.

Unleveled with No/Low Output Power:

1. Set up the MG369xB as follows:
 - a. Frequency: Step Sweep
 - b. F1: 2.000 GHz (2.21 GHz with Option 4)
 - c. F2: 20.000 GHz
 - d. More: Number of Steps: 400
 - e. Previous: L1: +1.00 dBm
 - f. Level: ALC Mode: Leveling
 - g. Leveling: External Detector
2. Connect the X input of an oscilloscope to the MG369xB rear panel HORIZ OUT connector.
3. Using the oscilloscope, check the switched filter bias voltages at A1J10 pin13 and A1J10 pin 9. The bias voltage at A1J10 pin 13 should be +7 volts; the bias voltage at A1J10 pin 9 should be +8 volts. If the MG369xB has a SDM installed, also check for a +20 volt PIN switch drive voltage at A1J6 pin 3B.
 - If the bias and the PIN switch drive voltages are correct, go to step 4.
 - If the bias voltages are not correct, refer to the troubleshooting [Table 5-5](#) to determine if the power supply or regulator PCB needs to be replaced.
 - If the PIN switch drive voltage is not correct, replace the A6 PCB.
4. Connect a 56100A Scalar Network Analyzer to the MG369xB as follows:
 - a. Connect the MG369xB AUX I/O to the 56100A AUX I/O.
 - b. Connect the 56100A DEDICATED GPIB to the MG369xB IEEE-488 GPIB.
 - c. Connect the RF detector to the 56100A Channel A input.

5. Set up the 56100A scalar network analyzer as follows:
 - a. Press the **SYSTEM MENU** key.
 - b. From System menu display, select **RESET**.
 - c. Press **CHANNEL 2 DISPLAY: OFF**
 - d. Press **CHANNEL 1 DISPLAY: ON**
 - e. Press the **CHANNEL 1 MENU** key.
 - f. From the Channel 1 menu display, select **POWER**.
6. Using the scalar network analyzer with a 10 dB pad, measure the RF output at J2 of the switched filter assembly. The amplitude of the RF signal should be $> +15$ dBm ($> +20$ dBm with Option 15) throughout the full sweep.
 - If the amplitude of the RF signal is correct, check for bad RF cables.
 - If there is no RF signal or if the amplitude of the RF signal is low, replace the A10 switched filter assembly.

Table 5-24. Error Messages 130, 131, 132, 133 and 134

- Error 130 2-3.3 GHz Switched Filter**
- Error 131 3.3-5.5 GHz Switched Filter**
- Error 132 5.5-8.4 GHz Switched Filter**
- Error 133 8.4-13.25 GHz Switched Filter**
- Error 134 13.25-20 GHz Switched Filter**

Description: Each of these error messages indicates a failure in a switched filter path within the switched filter assembly. The MG369xB may or may not produce an RF output in the frequency range of the failed switched filter path.

1. Set up the MG369xB as follows:
 - a. Frequency: Step Sweep
 - b. F1: 2.000 GHz (2.21 GHz with Option 4)
 - c. F2: 20.000 GHz
 - d. More: Number of Steps: 400
 - e. Previous: L1: +1.00 dBm
 - f. Level: ALC Mode: Leveling
 - g. Leveling: External Detector
2. Connect the X input of an oscilloscope to the MG369xB rear panel HORIZ OUT connector.
3. Using the oscilloscope, check for the switched filter PIN switch drive voltages at the test points shown in [Table 5-25](#).
 - If the PIN switch drive voltages are correct, replace the switched filter assembly.
 - If the PIN switch drive voltages are incorrect, replace the A6 ALC PCB.

Table 5-25. Switched Filter Pin Switch Drive Voltages

Test Point	Active Frequency Range	Active Voltage	Inactive Voltage
A1J10 pin 14	2 to 3.3 GHz	-2.3V	+1.0V
A1J10 pin 5	3.3 to 5.5 GHz	-2.0V	+1.0V
A1J10 pin 4	5.5 to 8.4 GHz	-2.0V	+1.0V
A1J10 pin 3	8.4 to 13.25 GHz	-2.0V	+1.0V
A1J10 pin 2	13.25 to 20 GHz	-2.0V	+1.0V
A1J10 pin 6	2 to 8.4 GHz	-2.3V	+1.0V

Table 5-26. Error Message 135

Error 135 Modulator or Driver Failed

Description: Error 135 indicates a failure of the modulator in the switched filter assembly or the modulator driver circuitry on the A6 ALC PCB.

1. Replace the A6 PCB and run self-test.
 - If error 135 is not displayed, the problem is cleared.
 - If error 135 is still displayed, go to step 2.
2. Replace the switched filter assembly and run self-test again.
 - If error 135 is not displayed, the problem is cleared.
 - If error 135 is still displayed, contact your local Anritsu service center for assistance.

Table 5-27. Error Message 138

Output Power Level Related Problems**MG369xB Models with SDM (30 or 40 GHz)****Error 138 SDM Unit or Driver Failed**

Description: Error 138 indicates a failure of the SDM or a failure of the SDM bias regulator or frequency band selection circuitry on the A6 ALC PCB. The MG369xB will not produce an RF output in the 20 to 40 GHz frequency range.

1. Set up the MG369xB as follows:
 - a. Frequency: Step Sweep
 - b. F1: 20.000 GHz
 - c. F2: 40.000 GHz (30 GHz for MG3693B)
 - d. More: Number of Steps: 400
 - e. Previous: L1: +1.00 dBm
 - f. Level: ALC Mode: Leveling
 - g. Leveling: External Detector
2. Connect the X input of an oscilloscope to the MG369xB rear panel HORIZ OUT connector.
3. Using the oscilloscope, check for a +8 volts SDM bias voltage at A1J5 pin 6A throughout the full sweep.
 - If the SDM bias voltage is correct, replace the SDM.
 - If the SDM bias voltage is not correct, go to step 4.
4. Using the oscilloscope, check for a +8 volts SDM bias voltage at A1J5 pin 5A.
 - If the +8 volt bias is correct, replace the A5 PCB.
 - If the +8 volt bias is not correct, refer to the troubleshooting [Table 5-5](#) to determine if the power supply or regulator needs to be replaced.
5. Run self-test.
6. If error 138 is not displayed, the problem is cleared.
7. If error 138 is still displayed, contact your local Anritsu service center for assistance.

Table 5-28. Error Messages 139, 140 and 141

Error 139 32-40 GHz SDM Section Failed
Error 140 25-32 GHz SDM Section Failed
Error 141 20-25 GHz SDM Section Failed

Description: Each of these error messages indicates a failure in a switched doubler filter path within the SDM. The MG369xB will not produce an RF output in the frequency range of the failed switched doubler filter path.

1. Set up the MG369xB as follows:
 - a. Frequency: Step Sweep
 - b. F1: 2.000 GHz
 - c. F2: 40.000 GHz (30 GHz for MG3693B)
 - d. More: Number of Steps: 400
 - e. Previous: L1: +1.00 dBm
 - f. Level: ALC Mode: Leveling
 - g. Leveling: External Detector
2. Connect the X input of an oscilloscope to the MG369xB rear panel HORIZ OUT connector.
3. Using the oscilloscope, check the PIN switch drive voltages shown in [Table 5-29](#).
 - If the PIN switch drive voltages are correct, replace the SDM.
 - If the PIN switch drive voltages are not correct, replace the A6 PCB.

Table 5-29. SDM PIN Switch Drive Voltages

Test Point	Active Frequency Range	Active Voltage	Inactive Voltage
A1J16 ⁽¹⁾ pin 3B	0.01 to 20 GHz	+20V	-15V
A1J16 ⁽¹⁾ pin 3C	20 to 25 GHz	+20V	-15V
A1J16 ⁽¹⁾ pin 4A	25 to 32 GHz	+20V	-15V
A1J16 ⁽¹⁾ pin 4B	32 to 40 GHz	+20V	-15V

1. Connector is labeled J16 for front connector or J12 for rear connector.

Table 5-30. Error Message 144

Error 144 RF was Off when Self-test started. Some tests were not performed

Description: Indicates that some self-tests were not performed because the RF output was selected OFF on the front panel.

1. Press the OUTPUT key on the front panel to turn the RF output ON.
2. Run self-test again. If error 144 is still displayed, contact your local Anritsu service center for assistance.

Table 5-31. Error Message 145

A6 AM Module**Error 145 AM Meter or associated circuitry failed**

Description: Indicates a failure of the internal amplitude modulation function. The MG369xB may or may not provide amplitude modulation of the RF output signal using modulating signals from an external source.

1. Set up the MG369xB as follows:
 - a. Press **System**, then Reset.
 - b. Press **MODULATION**, then AM to go to the Internal AM Status display.
 - c. Press On/Off to turn internal amplitude modulation on.
2. Using an oscilloscope, verify the presence of a 10 volt peak-to-peak sine wave signal with a period of 100 μ s at the rear panel AM OUT connector.
 - If present, replace the A6A1 module.
 - If not present, replace the A8 PCB.
3. Run self-test again. If error 145 is still displayed, contact your local Anritsu service center for assistance.

Table 5-32. Error Message 147

A7 FM Module**Error 147 Internal FM circuitry failed**

Description: Indicates a failure of the internal frequency modulation function. The MG369xB may or may not provide frequency modulation of the RF output signal using modulating signals from an external source.

1. Set up the MG369xB as follows:
 - a. Press **System**, then Reset.
 - b. Press **MODULATION**, then FM to go to the Internal FM Status display.
 - c. Press On/Off to turn internal frequency modulation on.
2. Using an oscilloscope, verify the presence of a 10 volt peak to peak sine wave signal with a period of 10 ms at the rear panel FM OUT connector.
 - If present, replace the A7A1 FM module.
 - If not present, replace the A8 PCB.
3. Run self-test again. If error 147 is still displayed, contact your local Anritsu service center for assistance.

Table 5-33. Error Message 148

Pulse Reference Circuitry**Error 148 Pulse 40 MHz reference circuitry failed.**

Description: Indicates a failure of the pulse generator 40 MHz oscillator circuitry. The pulse generator may still function; however, the 40 MHz oscillator is not phase locked to the 10 MHz reference time base. The pulse modulation function may or may not operate. **Error 106 (Power Supply not Phase-locked)** may also be displayed.

1. Disconnect the MCX cable at A13J1 or A8J1 (depending on option configuration).
2. Using an oscilloscope, verify the presence of a 10 MHz at the end of the MCX cable.
 - If present, replace the A13 PCB or A8 PCB (depending on option configuration).
 - If not present, go to step 3.
3. Reconnect the MCX cable to A13J1 or A8J1 and disconnect the MCX cable at A3J10.
4. Using the oscilloscope, verify the presence of a 10 MHz TTL signal at A3J10.
 - If present, replace the MCX cable.
 - If not present, replace the A3 PCB.
5. Run self-test again. If error 148 is still displayed, contact your local Anritsu service center for assistance.

Table 5-34. Error Message 136

Output Power Related Problems (> 40 GHz) MG369xB Models with SQM

Error 136 SQM Unit or Driver Failed

Description: Error 136 indicates a failure of the SQM or a failure of the SQM bias regulator or frequency band selection circuitry on the A6 PCB. The MG369xB will not produce an RF output above 40 GHz.

1. Set up the MG369xB as follows:
 - a. MG369xB Setup:
 - CW/SWEEP SELECT: Step
 - F1: 40.0 GHz
 - F2: 50.0, 60.0, 65.0, or 67.0 GHz (model dependent)
 - Number of Steps: 400
 - L1: -2.0 dBm
2. Connect the X input of an oscilloscope to the MG369xB rear panel HORIZ OUT connector.
3. Using the oscilloscope, check the following voltages:
 - a. For the MG3695B, check the SQM bias voltages at A6P3 pin 1 and A6P3 pin 5. The bias voltage at A6P3 pin 1 should be +10 volts; the bias voltage at A6P3 pin 5 should be -5 volts.
For the MG3696B, check for a +10 volts SQM bias voltage at A6P3 pin 1.
 - b. For all models, check for a -2 volt PIN switch drive voltage at A1J10 pin 10.
 - If the SQM bias and the PIN switch drive voltages are correct, go to step 4.
 - If the pin switch drive or SQM bias voltage(s) is not correct, replace the A6 PCB.
4. Connect a 56100A Scalar Network Analyzer to the MG369xB as follows:
 - a. Connect the MG369xB AUX I/O to the 56100A AUX I/O.
 - b. Connect the 56100A DEDICATED GPIB to the MG369xB IEEE-488 GPIB.
 - c. Connect the RF Detector to the 56100A Channel A Input.
5. Set up the 56100A Scalar Network Analyzer as follows:
 - a. Press the **SYSTEM MENU** display.
 - b. From System Menu display, select **RESET**.
 - c. Press **CHANNEL 2 DISPLAY: OFF**.
 - d. Press **CHANNEL 1 DISPLAY: ON**.
 - e. Press **CHANNEL 1 Menu** key.
 - f. From the Channel 1 Menu display, select **POWER**.
6. Using the scalar network analyzer, measure the RF output at J4 of the switched filter assembly. The amplitude of the RF signal should be > +18 dBm throughout the full sweep.
 - If the amplitude of the RF signal is correct, replace the SQM.
 - If there is no RF signal or if the amplitude of the RF signal is low, replace the switched filter assembly.
7. Run self-test again. If error 136 is still displayed, contact your local Anritsu service center for assistance.

Chapter 6 — Removal and Replacement Procedures

6-1 Introduction

This chapter provides a table of replaceable parts and procedures for gaining access to the major MG369xB assemblies, subassemblies, and components for troubleshooting or replacement. Replacing most assemblies will require additional adjustments to the instrument. Refer to [Table 6-2](#) for a calibration/verification rework guide.

Warning

Hazardous voltages are present inside the MG369xB whenever AC line power is connected. Turn off the instrument and remove the line cord before removing any covers or panels. Troubleshooting and repair procedures should only be performed by service personnel who are fully aware of the potential hazards.

Caution

ESD Requirements: The MG369xB contains components that can be easily damaged by electrostatic discharge (ESD). An ESD safe work area and proper ESD handling procedures that conform to ANSI/ESD S20.20-1999 or ANSI/ESD S20.20-2007 is mandatory to avoid ESD damage when handling subassemblies or components found in the S312D instrument. Repair of damage that is found to be caused by electrostatic discharge is not covered under warranty.

Note

Many assemblies, subassemblies, and components within the MG369xB family of instruments are type and model dependent. Before replacing an assembly, subassembly, or component, always verify the part number of the replacement item. Part numbers can be found in [Table 6-1](#) on the following page.

Note

When replacing RF components with SMA, K or V connectors it is important to torque these to the proper value. In the MG3690B unit that setting is 8 Inch/LBs. You can purchase a Anritsu torque wrench which is set to 8 inch/LB. The Anritsu part number is 01-201.

6-2 Replaceable Parts

Anritsu maintains an exchange assembly program for selected MG369xB subassemblies and RF components. If one of these subassemblies malfunction, the defective instrument can be exchanged. All exchange subassemblies and RF components are warranted for 90 days from the date of shipment, or for the balance of the original equipment warranty, whichever is longer.

Please have the exact model number and serial number of your instrument available when requesting this service, as the information about your instrument is filed according to the instrument's model and serial number. For more information about the program, contact your local sales representative or call your local Anritsu service center.

[Table 6-1](#) lists most replaceable parts and assemblies found in the MG369xB. All parts are exchange assemblies except fuses, fans, and front panel Model ID plates.

Table 6-1. MG369xB Replaceable Subassemblies and Part Numbers (Sheet 1 of 3)

Assembly Numbers	Subassembly or Part Name	Anritsu Part Number	Anritsu Alternate Part Number to order	Model or Option List
	Line Fuse (5 Amp Slow Blow)	631-33		All Models
	AC Input Module with EMI Filter	260-23		All Models
	Power Supply, Main	40-147	3-40-147	All Models
	Power Supply, Standby	ND68049	3-40-171	All Models
	Fan Assembly, Power Supply	ND64381		All Models
	Fan Assembly, Rear Panel	ND64382		All Models
	Front Panel Assembly (excluding Model ID plate)	ND71721 (52349 plus knob)	ND73883	All Models
	MG3691B Model ID Plate	63814-6		MG3691B
	MG3692B Model ID Plate	63814-1		MG3692B
	MG3693B Model ID Plate	63814-2		MG3693B
	MG3694B Model ID Plate	63814-3		MG3694B
	MG3695B Model ID Plate	63814-4		MG3695B
	MG3696B Model ID Plate	63814-5 63814-7		MG3696B (65 GHz) MG3696B (67 GHz)
A2	Microprocessor PCB Assembly	ND71722 (52202-3)		All Models
A3	Reference/Fine Loop PCB Assembly	ND64370	ND68039	no 3, no 30, no 16
A3	Reference/Fine Loop PCB Assembly	ND64371	ND68038	3 or 30, no 16
A3	Reference/Fine Loop PCB Assembly	ND64372	ND68041	16, no 3, no 30
A3	Reference/Fine Loop PCB Assembly	ND64373	ND68040	3 or 30 and 16
A4	Fast Coarse Loop PCB Assembly	52259-3		no 3, no 30
A4	Coarse Loop PCB Assembly	D40624-3	ND67959 (if firmware > 3.40)	3
A4	Coarse Loop PCB Assembly	ND66803		30
A5	Auxiliary PCB Assembly	ND71723 (52245-3)	ND73176 (3-71664-3)	no 6
A5	Analog Instruction/Auxiliary PCB Assembly	ND71724 (52225-3)	ND73177 (3-71661-3)	6
A6	ALC PCB Assembly	ND66804		26 (Serial Numbers ≥ 060607)
A6	ALC PCB Assembly	52247-3		26 (by Serial Number)
A6A1	AM Module	ND71725 (52232-3)	ND73178 (3-71662-3)	14, 25X, or 28X
A6A2	Power Meter Module	ND71726 (52248-3)		8
A7	YIG Lock PCB Assembly with Sampler	ND64368		no 3, no 30

Table 6-1. MG369xB Replaceable Subassemblies and Part Numbers (Sheet 2 of 3)

Assembly Numbers	Subassembly or Part Name	Anritsu Part Number	Anritsu Alternate Part Number to order	Model or Option List
A7	YIG Lock PCB Assembly with Sampler	ND64369	ND73924 (3-71667-3)	3 or 30
A7A1	FM Module	ND71727 (52234-4)	ND73187 (3-71663-3)	12, 25X, or 28X
A8	Function Generator PCB Assembly	52233-3		23 or 25X
A8	Function Generator PCB Assembly	ND66805	ND73175 (3-71219-3)	27 or 28X
A9	YIG Module (2 to 10 GHz)	ND64374	ND74904 (3-71668-3)	MG3691B
A9	YIG Module (2 to 20 GHz)	ND64375	ND74903 (3-71668-3)	All Models except MG3691B
A11	Digital Down Converter Assembly	ND55519		4
A11	Down Converter Assembly	D27330		5
A13	Pulse Generator PCB Assembly	52222-3		24 or 25X
A20	Regulator PCB Assembly	52236-3	3-72415-3	All Models
A21	Rear Panel PCB Assembly	52244-3		26 (by Serial Number)
A21	Rear Panel PCB Assembly	52266-3	3-72420-3	26 (Serial Numbers ≥ 060607)
	Leveling Coupler, 40 GHz	ND60339		All Models except MG3695B and MG3696B
	Leveling Coupler, 65 GHz	ND60340		MG3695B and MG3696B
	Switched Filter	D45198		no 13X, no 15X, no 26X
	Switched Filter, Pulsed	D45200		13X, 26X, no 15X
	Switched Filter, Pulsed	64539		15X and 13X or 26X
	Switched Filter	64540		15X, no 13X, no 26X
	Output Connector, VF	C27300		MG3695B and MG3696B
	Output Connector, KF	C27310		All Models except MG3695B and MG3696B
	Switched Doubler Module	D28540		no 15X, no MG3691B or MG3692B
	Very High Power Switched Doubler Module	47520		15X
	Step Attenuator, 20 GHz	D27152		2A
	Step Attenuator, 40 GHz	D25080		2B
	Step Attenuator, 65 GHz	D28957		2C
	Electronic Step Attenuator	45720		2E

Table 6-1. MG369xB Replaceable Subassemblies and Part Numbers (Sheet 3 of 3)

Assembly Numbers	Subassembly or Part Name	Anritsu Part Number	Anritsu Alternate Part Number to order	Model or Option List
	2 to 20 GHz Amplifier	61854		15A
	2 to 50 GHz Amplifier and A14 Bias Board	ND64378		15B/C/D
	Source Quadrupler Module, 50 GHz	ND60341		MG3695B
	Source Quadrupler Module, 67 GHz	ND64377		MG3696B
	Source Quadrupler Module, 70 GHz	ND67167		MG3696B (units labeled 67 GHz)
	High Power Source Quadrupler Module, 70 GHz	ND64378		MG3696B (units labeled 67 GHz with Option 15D)
	37 GHz High Pass Filter	49247		MG3695B
	16.8 GHz Low Pass Filter with 6dB pad	B28612		MG3696B
	67 GHz Forward Coupler	C27184		MG3696B
	Mixer, 40 GHz	60-276		7
	Scan Modulator	1010-113		20
	Transfer Switch	1020-34 or 1020-61		20
	Diplexing Switch	ND64379		22
	Diplexing Switch, High Frequency	65902		MG3695B and MG3696B
	Lo-Band Diplexing Switch	ND64380		22

6-3 Calibration and verifications after replacing an assembly.

See [Table 6-2](#) to determine the required calibration and verifications after replacing an assembly.

Table 6-2. calibration and Verification Rework Guide (Sheet 1 of 3)

Assembly	Calibration/Verification Procedure	Section Number
A2 Processor (Data Recovered)	Preliminary Calibration	4-7
A2 Processor (Data Unrecovered)	Preliminary Calibration	4-7
	Switched Filter Shaper Calibration	4-9
	RF Level Calibration or Verification	3-9 or 4-10
	ALC Calibration	4-11
	Frequency Modulation Calibration and Verification	3-10 and 4-14
	AM Calibration and Verification	3-11 and 4-13

Table 6-2. calibration and Verification Rework Guide (Sheet 2 of 3)

Assembly	Calibration/Verification Procedure	Section Number
A3 Reference/Fine Loop	Preliminary Calibration	4-7
A4 Coarse Loop	Spurious Signals Verification	3-7
	Phase Noise Verification	3-8
A5 Analog Instruction or Auxiliary	Preliminary Calibration	4-7
	Frequency Modulation Calibration and Verification	3-10 and 4-14
A6 ALC	Switched Filter Shaper Calibration	4-9
	RF Level Calibration or Verification	3-9 or 4-10
	ALC Calibration	4-11
	ALC Slope Cal	4-12
	AM Calibration and Verification	3-11 and 4-13
	Pulse Modulation Verification	3-12
A7 YIG Lock/Sampler	Frequency Modulation Calibration and Verification	3-10 and 4-14
	Spurious Signals Verification	3-7
	Phase Noise Verification	3-8
A8 Internal Generator (Option 23 or 27)	Frequency Modulation Calibration and Verification	3-10 and 4-14
	AM Calibration and Verification	3-11 and 4-13
	Pulse Modulation Verification	3-12
A9 YIG Module Switched Filter or High Power (Option 15) Het Down Converter (Option 5) Digital Down Converter (Option 4)	Preliminary Calibration	4-7
	Switched Filter Shaper Calibration	4-9
	RF Level Calibration or Verification	3-9 or 4-10
	ALC Calibration	4-11
	Frequency Modulation Calibration and Verification	3-10 and 4-14
	AM Calibration and Verification	3-11 and 4-13
	Pulse Modulation Verification	3-12
	Phase Noise Verification	3-8
	ALC Slope Cal	4-12
Spurious Signals Verification	3-7	
A13 Pulse Generator (Option 24 or 25x)	Pulse Modulation Verification	3-12
A7A1 FM/Phase Modulation Module (Option 12)	Preliminary Calibration	4-7
	Frequency Modulation Calibration and Verification	3-10 and 4-14
	Spurious Signals Verification	3-7
	Phase Noise Verification	3-8
A6A1 AM Module (Option 14)	Preliminary Calibration	4-7
	RF Level Calibration or Verification	3-9 or 4-10
	AM Calibration and Verification	3-11 and 4-13
IF Up-Conversion (Option 7)	RF Level Calibration or Verification	3-9 or 4-10
Power Monitor (Option 8)	ALC Slope Cal	4-12
Rear Panel Output (Option 9)		
Output Connector		

Table 6-2. calibration and Verification Rework Guide (Sheet 3 of 3)

Assembly	Calibration/Verification Procedure	Section Number
Delete Front Panel (Option 17)	N/A	
mmW Bias Output (Option 18)	N/A	
Scan Modulation (Option 20)	RF Level Calibration or Verification	3-9 or 4-10
SDM or SQM	Switched Filter Shaper Calibration	4-9
	RF Level Calibration or Verification	3-9 or 4-10
	Phase Noise Verification	3-8
	Spurious Signals Verification	3-7
Front Panel	Spurious Signals Verification	3-7
Regulator	Phase Noise Verification	3-8
Power Supply		

6-4 Chassis Covers

Troubleshooting procedures require removal of the top and bottom covers. Replacement of some MG369xB assemblies and parts require removal of all covers. The following procedure describes this process.

Tool Required

1 Phillips screwdriver

Preliminary

Disconnect the power cord from the instrument.

Procedure

Remove and replace the chassis covers as follows:

Note	The screws with green heads have metric threads. When it becomes necessary to replace any of these screws, always use the exact replacement green-headed screws to avoid damage to the instrument. Anritsu PN: 905-8 (long); Z-951102 (short).
-------------	--

1. Use a Phillips screwdriver to remove the screws and the front handle assemblies from the instrument (see [Figure 6-1](#)). For models not having front handles, remove the screws and the front top and bottom feet from the instrument. Retain the screws.
2. Use a Phillips screwdriver to remove the four feet from the rear of the instrument. Retain the screws.
3. Remove the screw that fastens the top cover to the chassis (see [Figure 6-2 on page 6-8](#)).
4. At the rear of the instrument pull the cover upwards about 1.5 inches then pull the cover towards the rear of the instrument while sliding the cover out along the grooves in the chassis.
5. Turn the instrument over so that the bottom cover is on top.
6. Remove the screw that fastens the bottom cover to the chassis. See [Figure 6-2](#). At the rear of the instrument pull the cover upwards about 1.5 inches then pull the cover towards the rear of the instrument while sliding the cover out along the grooves in the chassis.
7. To replace the chassis covers, reverse the procedure used to remove them.

Note	It is necessary to remove the side covers only if the front panel is to be removed in a later step.
-------------	---

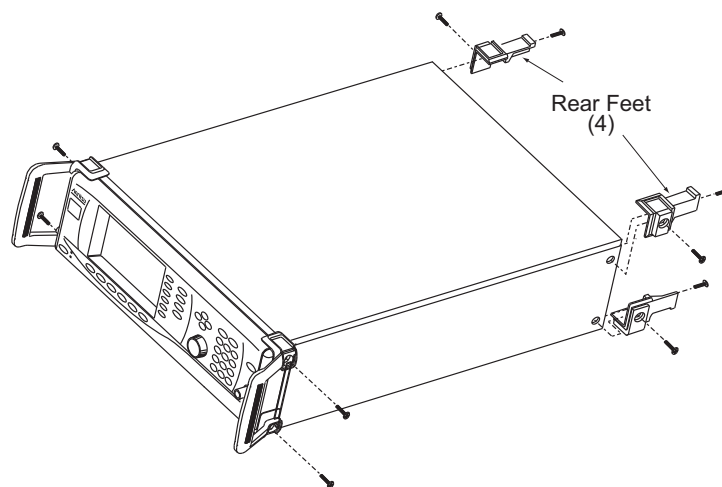

Figure 6-1. Front Handle and Rear Feet Removal

8. If the side covers need to be removed, turn the instrument over to return it to the upright position.
9. Remove the screw that fastens the left side cover to the chassis. See [Figure 6-2](#).
10. Remove the side cover and set it aside.
11. Remove the screw that fastens the right side cover to the chassis. See [Figure 6-2](#).
12. Remove the side cover and set it aside.
13. To replace the chassis covers, reverse the procedure used to remove them.

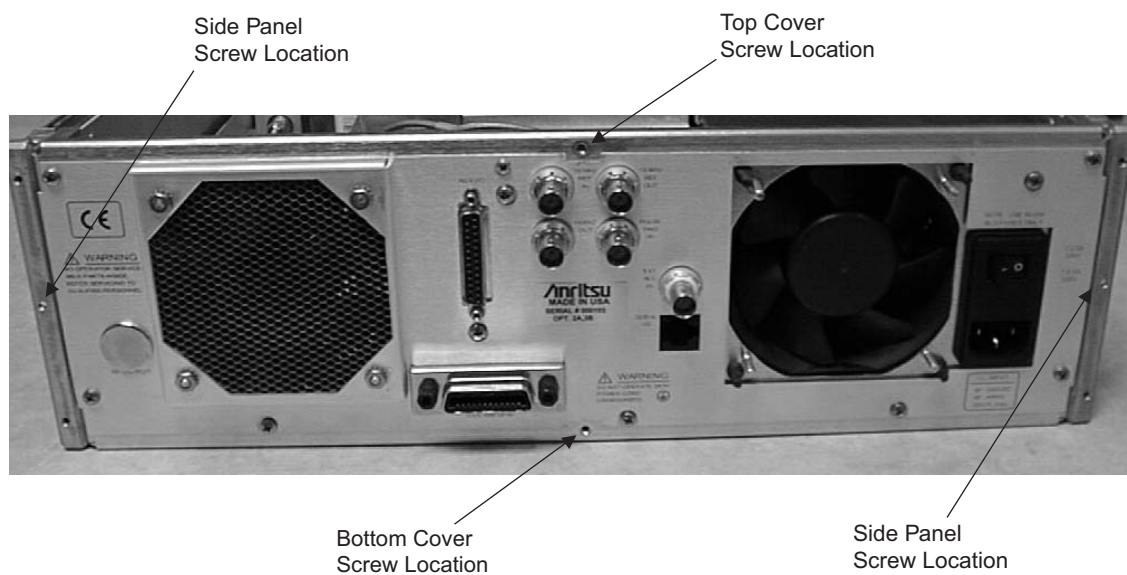

Figure 6-2. Rear Panel Retaining Screw Locations

6-5 Front Panel Assembly

This paragraph provides instructions for removing and replacing the front panel assembly of the MG369xB. The front panel assembly contains the A1 front panel PCB. Refer to [Figure 6-3](#) and [Figure 6-4](#) during this procedure.

Preliminary

Remove the front handles, rear feet, and chassis covers as described in [Section 6-4](#).

Procedure

Remove and replace the front panel assembly as follows:

1. With the front handles and chassis covers removed, place the MG369xB on a flat surface, with the top side up.
2. Carefully pull the front panel away from the chassis to gain access to the front panel ribbon cable that connects the front panel PCB assembly to the microprocessor PCB assembly. See [Figure 6-4](#).
3. Disconnect the front panel ribbon cable from the connector on the front panel PCB assembly. See [Figure 6-3](#).
4. Carefully pull the front panel assembly forward until it is clear of the RF OUTPUT connector. Set front panel aside.
5. To replace the front panel assembly, reverse the removal process.

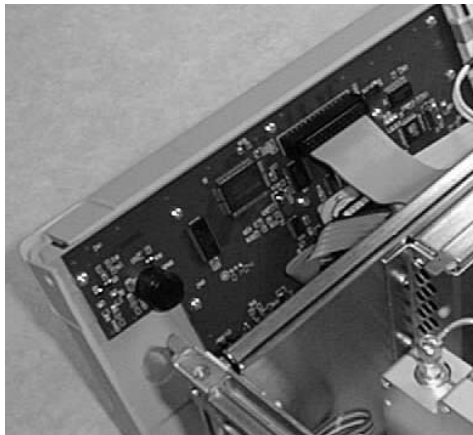

Figure 6-3. Front Panel Ribbon Connector Detail



Figure 6-4. Front Panel Removal

6-6 A2 Microprocessor PCB Board

This paragraph provides instructions for removing and replacing the A2 microprocessor PCB which is located immediately behind the front panel in a shielded card cage. See [Figure 6-6](#).

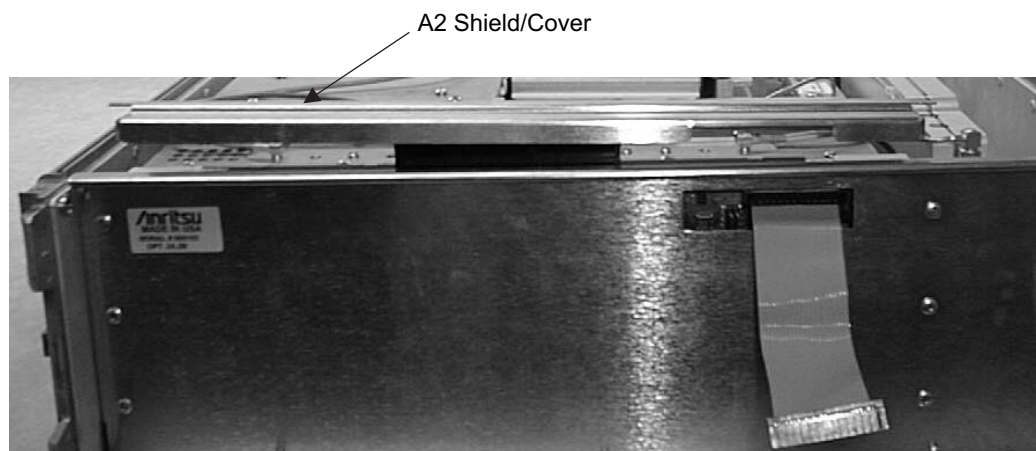

Figure 6-5. A2 Microprocessor PCB Removal

Preliminary

If possible, save the calibration information using Anritsu's calibration data save/restore software (P/N 2300-478). The process is:

1. Install the software.
2. Connect the MG369xB to the GPIB bus and power on the MG369xB.
3. Start the program.
4. Click on **Save to Disk**.
5. Pick an appropriate location and save the file. It should only take a few moments.

Remove the front panel assembly as described in [Section 6-5](#).

Procedure

Remove and replace the A2 microprocessor PCB as follows:

1. Grasp the lifting tabs on the sides of the microprocessor shield/cover and remove. (Some models may have retention screws that need to be removed from the lift tabs.)
2. Carefully disconnect the ribbon cable from the connector J2 of the microprocessor board. Note the orientation of the red stripe.
3. Using the card extractor handles, lift and remove the microprocessor board from the card cage.
4. To replace the microprocessor board, reverse the removal process.

Note	When reconnecting the ribbon cable, the edge with the red stripe should be located to the right as seen from the front of the instrument.
-------------	---

6-7 A3 Reference/Fine Loop PCB

This paragraph provides instructions for removing and replacing the A3 reference/fine loop PCB, which is located in a shielded enclosure immediately behind the microprocessor board card cage.

Preliminary

Remove the front handles, rear feet, and top cover as described in [Section 6-4](#).

Procedure

Remove and replace the reference/fine loop PCB as follows:

1. Carefully disconnect the coaxial cables from the top connectors of the A3 PCB assembly. See [Figure 6-6](#) and [Figure 6-7](#).
2. Use a Phillips screwdriver to remove the nine retaining screws from the A3 shield cover. Retain the screws.
3. Remove cover and set aside.
4. Using the card extractor handles, lift and remove the A3 PCB from its enclosure.
5. To replace the A3 PCB, reverse the removal process.

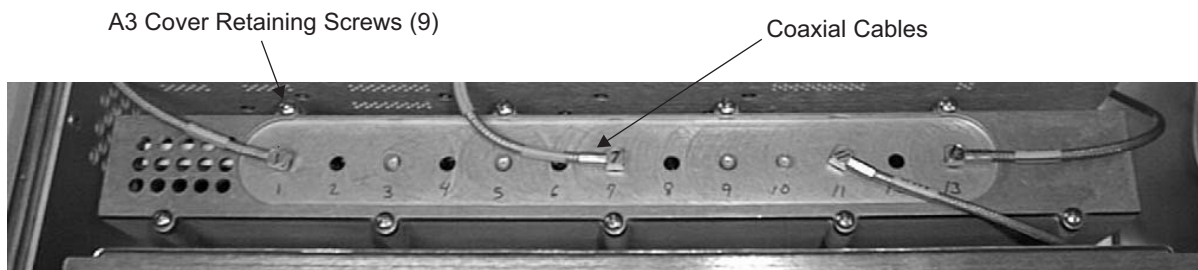

Figure 6-6. A3 Reference/Fine Loop PCB Cover Removal

6-8 A4 Coarse Loop PCB

This section provides instructions for removing and replacing the A4 coarse loop PCB assembly, which is located immediately behind the A3 reference/fine loop PCB assembly.

Preliminary

Remove the front handles, rear feet, and top cover as described in [Section 6-4](#). For models with Option 3 or 30, the A4 PCB and shield assembly are removed as a single unit and the bottom cover to the instrument must also be removed.

Procedure

Remove and replace the A4 PCB assembly as follows: (models without Option 3 or 30).

1. Carefully disconnect the coaxial cables from the top connectors of the A4 PCB assembly. Refer to [Figure 6-7](#).
2. Use a Phillips screwdriver to remove the nine retaining screws from the A4 shield cover assembly. Retain the screws.
3. Remove the cover and set it aside.
4. Using the card extractor handles, lift and remove the A4 PCB from its enclosure.
5. To replace the A4 PCB assembly, reverse the removal process.

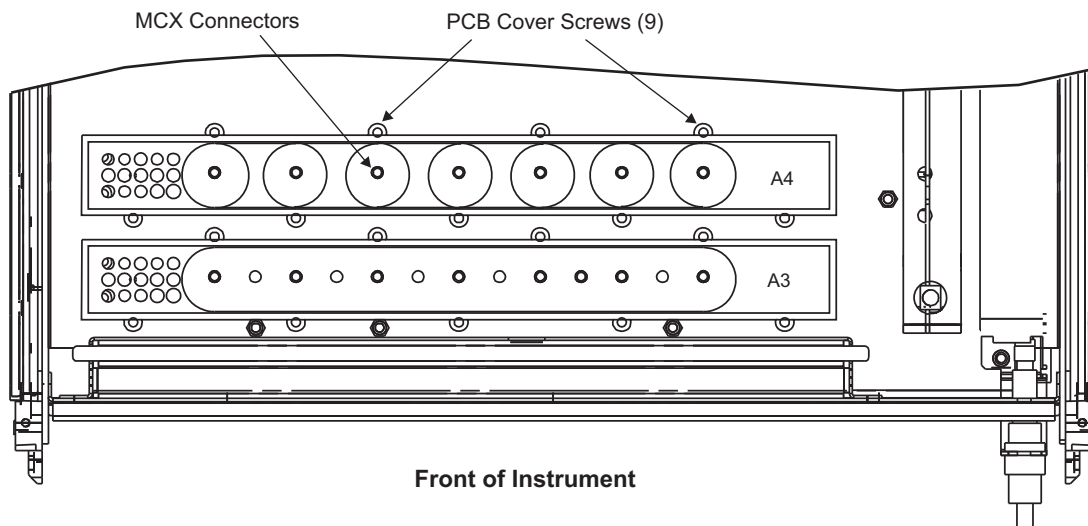

Figure 6-7. A3 Reference/Fine Loop and A4 Coarse Loop PCB Assembly Removal

Remove and replace the A4 PCB assembly as follows: (models with Option 3 or 30).

1. Carefully disconnect the coaxial cables from the top connectors of the A4 PCB assembly.
2. Turn the chassis upside down and locate the four retaining screws for the A4 board assembly. Refer to [Figure 6-8](#).
3. Use a Phillips screwdriver to remove the retaining screws. Retain the screws.
4. Turn the chassis right side up. Disconnect the A4 PCB assembly by lifting it from the chassis connector and set it aside.
5. To replace the A4 PCB assembly, reverse the removal process.

6-9 A5 to A13 PCB Removal

For access to the A5, A6, A7, A8, A9 and A13 PCB assemblies the card cage cover must be removed first, as follows:

Preliminary

Remove the front handles, rear feet, and top cover as described in [Section 6-4](#).

Card Cage Cover

Remove the card cage cover as follows:

1. Use a Phillips screwdriver to remove the two screws that secure the card cage cover, see [Figure 6-9](#). Retain the screws.
2. Pull the cover up and to the right, as seen from the front, to remove. Set the cover aside.

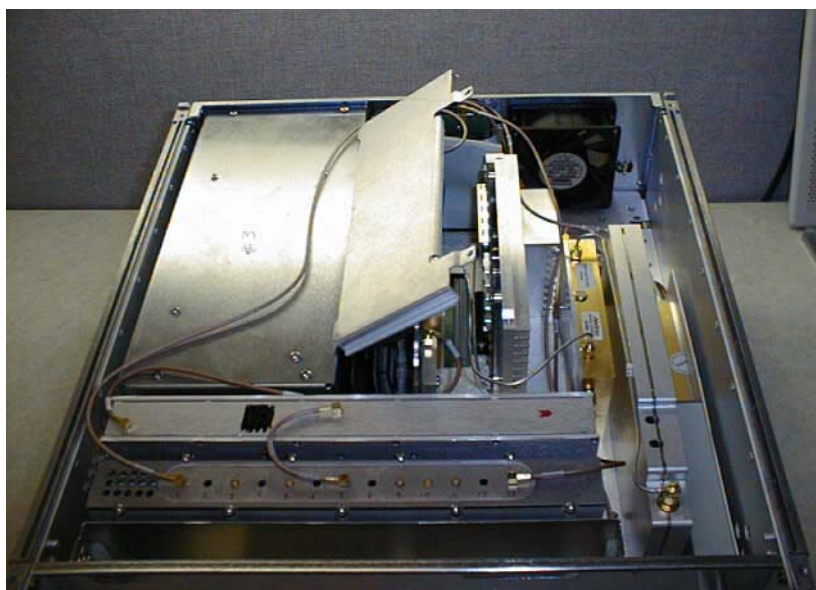

Figure 6-9. Removal of Card Cage Cover Retaining Screws

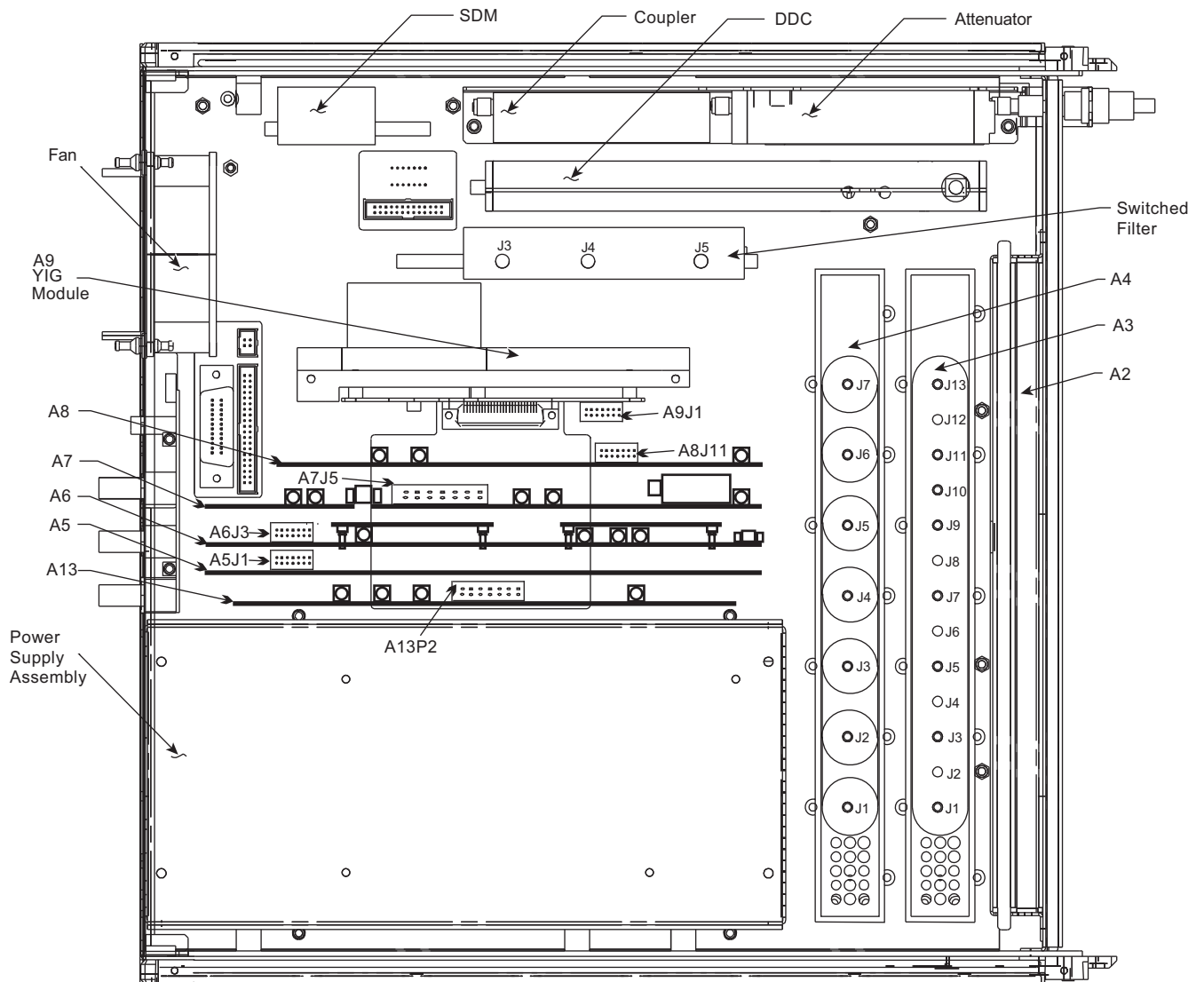

Figure 6-10. Locations of A5, A6, A7, A9 and A13 PCB Assemblies

A5 Auxiliary PCB

To remove the A5 auxiliary PCB, proceed as follows:

1. Grasp the A5 PCB by the edges and pull up to remove the board from the chassis connector.
See [Figure 6-10](#) for locations of the A5, A6, A7, A8, A9 and A13 PCBs.
2. To install the A5 PCB, reverse the removal process.

A6 ALC PCB

To remove the A6 ALC PCB, proceed as follows:

1. Disconnect the coaxial cables from the top edge of the A6 PCB.
2. Grasp the A6 PCB by the edges and pull up to remove the board from the chassis connector.
3. To install the A6 ALC PCB, reverse the removal process.

A7 YIG Lock PCB

To remove the A7 YIG lock PCB, proceed as follows:

1. Disconnect the miniature coax cable connectors from the top edge of the A7 PCB.
2. Disconnect the hard coax cable line from the A7 board sampler at the coax connector on the switched filter assembly.
3. Grasp the A7 PCB by the edges and gently pull up to remove the board from the chassis connector.
4. To install the A7 YIG lock PCB, reverse the removal process.

A9 YIG Assembly

To remove the A9 YIG assembly, proceed as follows:

1. Disconnect the hard coax cable line that connects the A9 module to the switched filter assembly at the coax connector on the switched filter assembly.
2. Turn the chassis upside down and locate the three retaining screws for the A9 YIG assembly. Refer to [Figure 6-8 on page 6-13](#).
3. Use a Phillips screwdriver to remove the three retaining screws. Retain screws.
4. Turn the chassis right side up. Disconnect the A9 assembly from the chassis connector and set aside.
5. To install the A9 YIG assembly, reverse the removal process.

A13 Pulse Generator PCB

To remove the A13 Pulse Generator PCB, proceed as follows:

1. Disconnect the miniature coax cable connectors from the top edge of the A13 PCB.
2. Grasp the A13 PCB by the edges and gently pull up to remove the board from the chassis connector.
3. To install the A13 YIG lock PCB, reverse the removal process.

6-10 Power Supply Assembly

This section provides instructions for removing and replacing the power supply assembly, which is located in a shielded enclosure at the left rear of the instrument.

Preliminary

It is necessary to first remove the card cage cover and instrument side cover, as described in [Section 6-9](#).

Power Supply Top Assembly

To remove and replace the power supply top cover/ top assembly, proceed as follows:

1. At the rear of the instrument, remove the four screws from the fan filter guard located immediately behind the power supply assembly ([Figure 1-1 on page 1-4](#)). Remove the fan filter guard (and honeycomb) and set it aside. Retain the screws.
2. Locate the six screws that secure the rear panel to the chassis and power supply (see [Figure 6-11](#)). Use a Phillips screw driver to remove the screws (retain the screws). The last screw is found on the side panel.
3. Gently pull the rear panel away from the chassis to gain access to the top rear power supply cover screws.
4. Use a Phillips screw driver to remove the four screws that secure the top subassembly (cover and PDU power supply unit) of the power supply assembly. Refer to [Figure 6-12](#) on the following page.
5. Carefully lift the top subassembly off the power supply assembly. Hold the top subassembly securely. Disconnect the power input cable at connector J1 located to the rear of the PDU power supply unit. See [Figure 6-12](#).
6. Similarly, disconnect the cable from the top subassembly at connector P1 of the power supply regulator PCB (lower subassembly). Also disconnect the 2-wire PS Inhibit cable at the JP3 connector of the regulator PCB. Put the PDU power supply unit aside for later replacement.

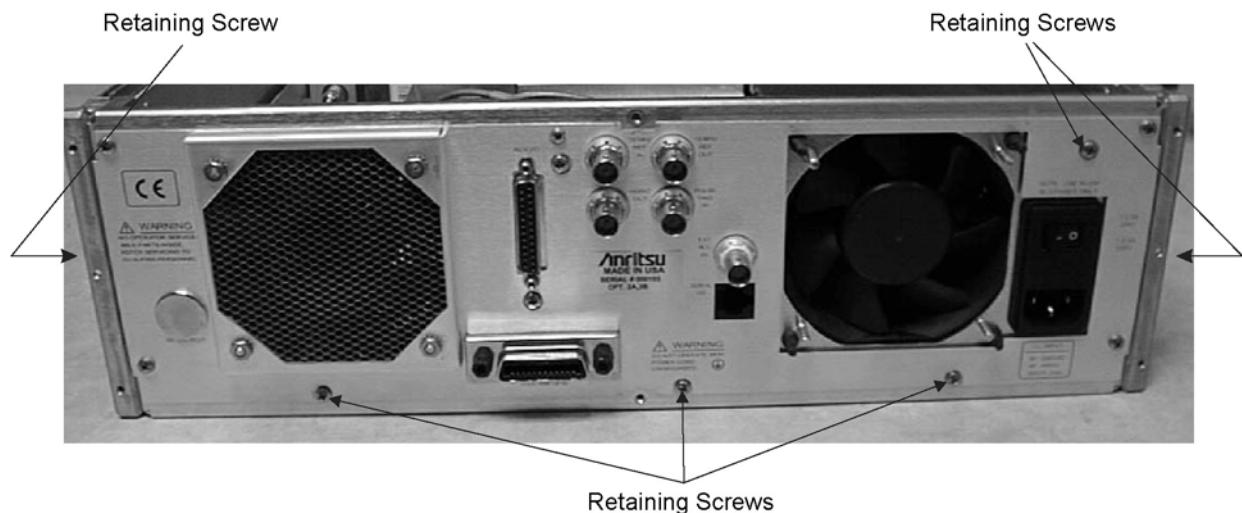

Figure 6-11. Rear Panel Retaining Screw Locations

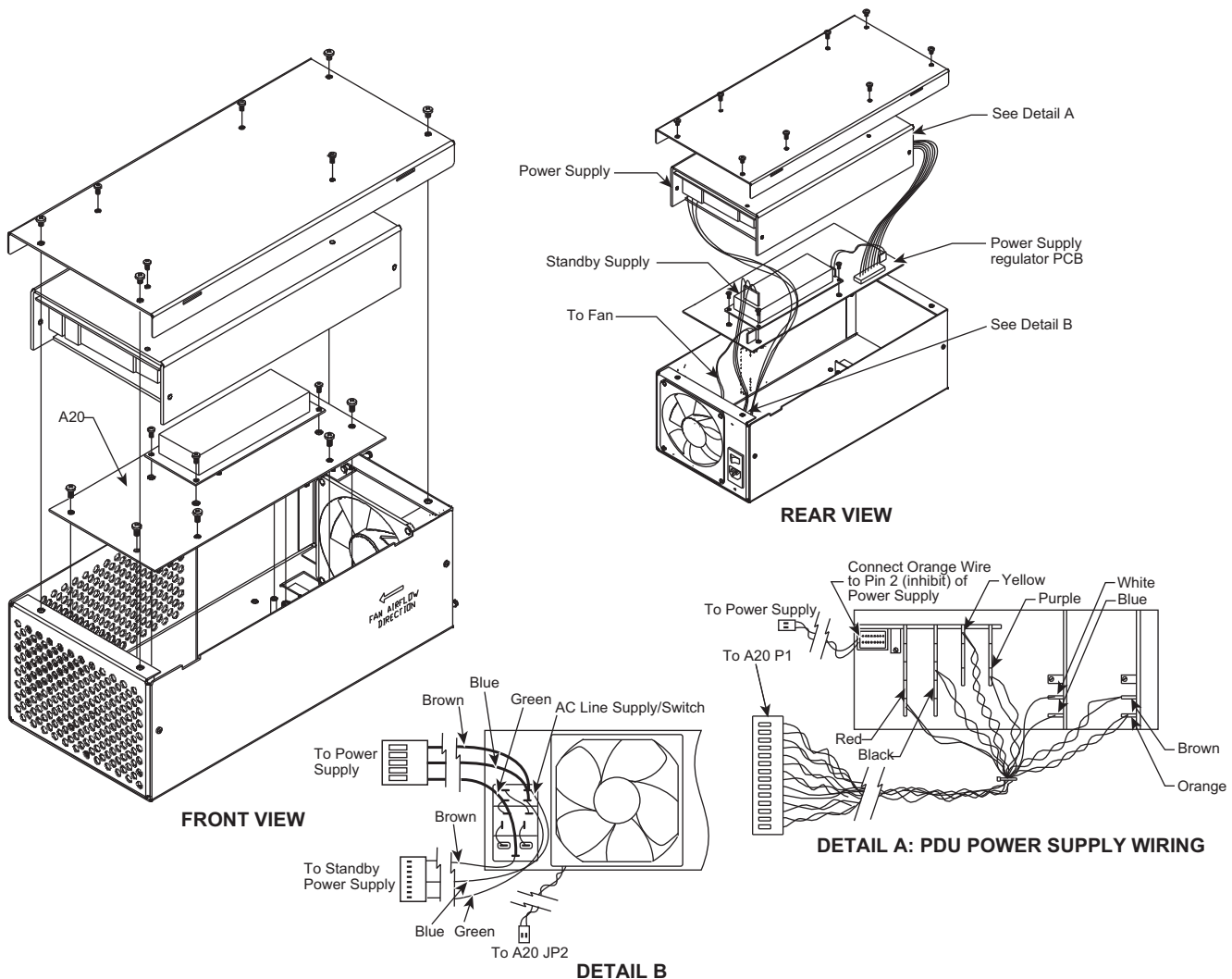

Figure 6-12. Power Supply Assembly

12 Volt Standby Power Supply PCB

To remove and replace the 12 volt standby power supply PCB from the power regulator PCB, proceed as follows:

1. If not done previously, remove the upper power supply top assembly (previous procedure).
2. Disconnect the 2-wire connector from connector JP1 of the power regulator PCB at connector CN2 of the 12 volt power supply PCB.
3. Use a Phillips screwdriver to remove the four screws that fasten the 12 volt power supply PCB to the chassis through the power regulator PCB. Retain the screws.
4. Remove the 12 volt standby power supply PCB by lifting it off of the mounting posts.
5. To install the power supply assembly, reverse the removal process.

A20 Power Supply Regulator

To remove and replace the lower power supply subassembly from the bottom of the power supply enclosure, proceed as follows:

1. If not done previously, remove the upper power supply top assembly and 12 volt standby power supply PCB (previous procedures).
2. Disconnect the 2-wire cable from the fan assembly at the JP2 connector of the power regulator PCB.
3. Use a Phillips screwdriver to remove the seven screws that fasten the regulator PCB to the power supply assembly. Retain screws. Remove the lower power supply subassembly from the power supply enclosure.
4. To install the power supply regulator, reverse the removal process.

Appendix A — Test Records

A-1 Introduction

This appendix provides test records for recording the results of the performance verification tests (Chapter 3) and the calibration procedures (Chapter 4). They jointly provide the means for maintaining an accurate and complete record of instrument performance. Test records are provided for all models of the series MG369xB Synthesized Signal Generators.

Some test records have been customized to cover particular MG369xB models. These test records contain specific references to frequency parameters and power levels that apply only to that instrument model and its available options. When a test record is customized, it is labeled with the specific model and option list for the particular instrument it covers. Test records, which are not customized, do not specify a specific model or option list. These test records are generic and may contain specific references to frequency parameters and power levels that exceed the operational limits of the instrument being tested. When using generic test records, only use the parameters that meet the operational limits of the instrument being tested.

A-2 Uncertainty Specifications

The uncertainty specifications provided in these test records apply only when the manufacturer and model of test equipment ([Table 3-1](#)), test setups, calibration and performance verification procedures, and other test guidelines found in this manual are used. For a description of measurement uncertainty, refer to [Section 3-5](#).

A-3 Test Records

We recommend that you make a copy of the test record pages each time a test procedure is performed. By dating each test record copy, a detailed history of the instrument's performance can be accumulated.

Test Records

MG369__B	Firmware Revision:	Operator:
Serial Number:	Date:	Options:

Section 3-6 Internal Time Base Aging Rate Test (Optional)

All MG369xB Models

	Date and Time	Measured Value	Upper Limit	Measurement Uncertainty
Frequency Error Value			N/A	N/A
Frequency Error Value (after 24 hours)			N/A	N/A
Computed Aging Rate	N/A	_____ per day	2×10^{-9} per day (5×10^{-10} per day with Option 16)	2×10^{-12} per day

MG369__B	Firmware Revision:	Operator:
Serial Number:	Date:	Options:

Section 3-7 Harmonics and Harmonically Related Signal Test Records

All MG369xB Models without Option 15 (Sheet 1 of 2)

Power level: The power level changes based on frequency, model and options installed. Set L1 to the lesser of +10 dBm or to the maximum specified power level.

Refer to Appendix B the Technical Data Sheet, for the maximum specified power levels.

Test Frequency (GHz)	Spectrum Analyzer's Span (MHz)	Spectrum Analyzer's BW/RBW/BW (kHz)	2nd Harmonic Frequency (GHz)	Measured Value (dBc)	3rd Harmonic Frequency (GHz)	Measured Value (dBc)	1/2 Sub Harmonic (GHz)	Measured Value (dBc)	1/4 Sub Harmonic (GHz)	Measured Value (dBc)	3/4 Sub Harmonic (GHz)	Measured Value (dBc)	Harmonic Related Upper Limit (dBc)	Measurement Uncertainty (dB)
----------------------	--------------------------------	-------------------------------------	------------------------------	----------------------	------------------------------	----------------------	------------------------	----------------------	------------------------	----------------------	------------------------	----------------------	------------------------------------	------------------------------

Frequencies: 0.1 Hz to 10 MHz (Models with Option 22 Only)

0.0001	10	1	0.0002		0.0003		N/A		N/A		N/A		-30	2.5
0.00075	10	1	0.0015		0.002250		N/A		N/A		N/A		-30	2.5
0.001	10	1	0.002		0.00300		N/A		N/A		N/A		-30	2.5
0.009999	10	1	0.019998		0.029997		N/A		N/A		N/A		-30	2.5

Frequencies: 10 MHz to ≤ 100 MHz (Models with Option 4 Only)

0.010	1	10	0.020		0.030		N/A		N/A		N/A		-40	2.5
0.015	1	10	0.030		0.045		N/A		N/A		N/A		-40	2.5
0.060	1	10	0.120		0.180		N/A		N/A		N/A		-40	2.5
0.100	1	10	0.200		0.300		N/A		N/A		N/A		-40	2.5

Frequencies: > 100 MHz to ≤ 2.2 GHz (Models with Option 4 Only)

0.1001	1	10	0.2002		0.3003		N/A		N/A		N/A		-50	0.8
0.500	1	10	1.000		1.500		N/A		N/A		N/A		-50	0.8
1.500	1	10	3.000		4.500		N/A		N/A		N/A		-50	0.8
2.000	1	10	4.000		6.000		N/A		N/A		N/A		-50	0.8
2.200	1	10	4.400		6.600		N/A		N/A		N/A		-50	0.8

Frequencies: 10 MHz to ≤ 50 MHz (Models with Option 5 Only)

0.010	1	10	0.020		0.030		N/A		N/A		N/A		-30	2.5
0.015	1	10	0.030		0.045		N/A		N/A		N/A		-30	2.5
0.030	1	10	0.060		0.090		N/A		N/A		N/A		-30	2.5
0.045	1	10	0.090		0.135		N/A		N/A		N/A		-30	2.5
0.050	1	10	0.100		0.150		N/A		N/A		N/A		-30	2.5

Test Records

MG369__B	Firmware Revision:	Operator:
Serial Number:	Date:	Options:

Section 3-7 Harmonics and Harmonically Related Signal Test Records

All MG369xB Models without Option 15 (Sheet 2 of 2)

Power level: The power level changes based on frequency, model and options installed. Set L1 to the lesser of +10 dBm or to the maximum specified power level.

Refer to Appendix B the Technical Data Sheet, for the maximum specified power levels.

Test Frequency (GHz)	Spectrum Analyzer's Span (MHz)	Spectrum Analyzer's BW/RBW/BW (kHz)	2nd Harmonic Frequency (GHz)	Measured Value (dBc)	3rd Harmonic Frequency (GHz)	Measured Value (dBc)	1/2 Sub Harmonic (GHz)	Measured Value (dBc)	1/4 Sub Harmonic (GHz)	Measured Value (dBc)	3/4 Sub Harmonic (GHz)	Measured Value (dBc)	Harmonic Related Upper Limit (dBc)	Measurement Uncertainty (dB)
----------------------	--------------------------------	-------------------------------------	------------------------------	----------------------	------------------------------	----------------------	------------------------	----------------------	------------------------	----------------------	------------------------	----------------------	------------------------------------	------------------------------

Frequencies: > 50 MHz to < 2 GHz (Models with Option 5 Only)

0.0501	1	10	0.1002		0.1503		N/A		N/A		N/A		-40	0.8
0.600	1	10	1.200		1.800		N/A		N/A		N/A		-40	0.8
1.500	1	10	3.000		4.500		N/A		N/A		N/A		-40	0.8
1.990	1	10	3.980		5.970		N/A		N/A		N/A		-40	0.8

Frequencies: 2 GHz (>2.2 GHz for Models with Option 4) to ≤ 20 GHz

2.0 ⁽¹⁾⁽²⁾	1	10	4		6		N/A		N/A		N/A		-60	0.8
2.201 ⁽²⁾	1	10	4.402		6.603		N/A		N/A		N/A		-60	0.8
9.99 ⁽²⁾	1	10	19.98		29.97		N/A		N/A		N/A		-60	2.5
10.01 ⁽²⁾	1	10	20.02		30.03		N/A		N/A		N/A		-60	2.5
20.0 ⁽²⁾	1	10	40		N/A		N/A		N/A		N/A		-60	2.5

Frequencies: > 20 GHz to ≤ 50 GHz (MG3693B, MG3694B, and MG3695B Only)

20.01 ⁽²⁾	1	10	40.02		N/A		10.005		5.0025		15.0075		-40	2.5
25.0 ⁽²⁾	1	10	50		N/A		12.5		6.25		18.75		-40	2.5
30.0 ⁽²⁾	1	10	N/A		N/A		15		7.5		22.5		-40	2.9
40.0 ⁽²⁾	1	10	N/A		N/A		20		10		30		-40	2.4
50.0 ⁽²⁾	1	10	N/A		N/A		25		12.5		37.5		-40	3.0

Frequencies: > 20 GHz to ≤ 67 GHz (MG3696B Only)

20.01 ⁽²⁾	1	10	40.02		N/A		10.005		5.0025		15.0075		-40	2.5
25.0 ⁽²⁾	1	10	50		N/A		12.5		6.25		18.75		-40	2.5
30.0 ⁽²⁾	1	10	N/A		N/A		15		7.5		22.5		-40	2.9
40.0 ⁽²⁾	1	10	N/A		N/A		20		10		30		-40	2.4
50.0 ⁽²⁾	1	10	N/A		N/A		25		12.5		37.5		-25	3.0

1. Not performed on units with Option 4.

2. Power level may change as the test frequency is increased.

MG369__B	Firmware Revision:	Operator:
Serial Number:	Date:	Options:

Section 3-7 Harmonics and Harmonically Related Signal Test Records

All MG369xB Models with Option 15 (Sheet 1 of 2)

Power level: The power level changes based on frequency, model and options installed. Set L1 to the lesser of +10 dBm or to the maximum specified power level.

Refer to Appendix B the Technical Data Sheet, for the maximum specified power levels.

Test Frequency (GHz)	Spectrum Analyzer's Span (MHz)	Spectrum Analyzer's BW/RBW/BW (kHz)	2nd Harmonic Frequency (GHz)	Measured Value (dBc)	3rd Harmonic Frequency (GHz)	Measured Value (dBc)	1/2 Sub Harmonic (GHz)	Measured Value (dBc)	1/4 Sub Harmonic (GHz)	Measured Value (dBc)	3/4 Sub Harmonic (GHz)	Measured Value (dBc)	Harmonic Related Upper Limit (dBc)	Measurement Uncertainty (dB)
----------------------	--------------------------------	-------------------------------------	------------------------------	----------------------	------------------------------	----------------------	------------------------	----------------------	------------------------	----------------------	------------------------	----------------------	------------------------------------	------------------------------

Frequencies: 0.1 Hz to 10 MHz (Models with Option 22 Only)

0.0001	10	1	0.0002		0.0003		N/A		N/A		N/A		-30	2.5
0.00075	10	1	0.0015		0.002250		N/A		N/A		N/A		-30	2.5
0.001	10	1	0.002		0.00300		N/A		N/A		N/A		-30	2.5
0.009999	10	1	0.019998		0.029997		N/A		N/A		N/A		-30	2.5

Frequencies: 10 MHz to ≤ 100 MHz (Models with Option 4 Only)

0.010	1	10	0.020		0.030		N/A		N/A		N/A		-40	2.5
0.015	1	10	0.030		0.045		N/A		N/A		N/A		-40	2.5
0.060	1	10	0.120		0.180		N/A		N/A		N/A		-40	2.5
0.100	1	10	0.200		0.300		N/A		N/A		N/A		-40	2.5

Frequencies: > 100 MHz to ≤ 2.2 GHz (Models with Option 4 Only)

0.1001	1	10	0.2002		0.3003		N/A		N/A		N/A		-50	0.8
0.500	1	10	1.000		1.500		N/A		N/A		N/A		-50	0.8
1.500	1	10	3.000		4.500		N/A		N/A		N/A		-50	0.8
2.000	1	10	4.000		6.000		N/A		N/A		N/A		-50	0.8
2.200	1	10	4.400		6.600		N/A		N/A		N/A		-50	0.8

Frequencies: 10 MHz to ≤ 50 MHz (Models with Option 5 Only)

0.010	1	10	0.020		0.030		N/A		N/A		N/A		-30	2.5
0.015	1	10	0.030		0.045		N/A		N/A		N/A		-30	2.5
0.030	1	10	0.060		0.090		N/A		N/A		N/A		-30	2.5
0.045	1	10	0.090		0.135		N/A		N/A		N/A		-30	2.5
0.050	1	10	0.100		0.150		N/A		N/A		N/A		-30	2.5

Test Records

MG369__B	Firmware Revision:	Operator:
Serial Number:	Date:	Options:

Section 3-7 Harmonics and Harmonically Related Signal Test Records

All MG369xB Models with Option 15 (Sheet 2 of 2)

Power level: The power level changes based on frequency, model and options installed. Set L1 to the lesser of +10 dBm or to the maximum specified power level.

Refer to Appendix B the Technical Data Sheet, for the maximum specified power levels.

Test Frequency (GHz)	Spectrum Analyzer's Span (MHz)	Spectrum Analyzer's BW/RBW/BW (kHz)	2nd Harmonic Frequency (GHz)	Measured Value (dBc)	3rd Harmonic Frequency (GHz)	Measured Value (dBc)	1/2 Sub Harmonic (GHz)	Measured Value (dBc)	1/4 Sub Harmonic (GHz)	Measured Value (dBc)	3/4 Sub Harmonic (GHz)	Measured Value (dBc)	Harmonic Related Upper Limit (dBc)	Measurement Uncertainty (dB)
----------------------	--------------------------------	-------------------------------------	------------------------------	----------------------	------------------------------	----------------------	------------------------	----------------------	------------------------	----------------------	------------------------	----------------------	------------------------------------	------------------------------

Frequencies: > 50 MHz to < 2 GHz (Models with Option 5 Only)

0.0501	1	10	0.1002		0.1503		N/A		N/A		N/A		-40	0.8
0.600	1	10	1.200		1.800		N/A		N/A		N/A		-40	0.8
1.500	1	10	3.000		4.500		N/A		N/A		N/A		-40	0.8
1.990	1	10	3.980		5.970		N/A		N/A		N/A		-40	0.8

Frequencies: > 40 GHz to ≤ 67 GHz (MG3696B Only)

50.0 ⁽¹⁾	1	10	N/A		N/A		25		12.5		37.5		-25	3.0
---------------------	---	----	-----	--	-----	--	----	--	------	--	------	--	-----	-----

1. Power level may change as the test frequency is increased.

MG369__B	Firmware Revision:	Operator:
Serial Number:	Date:	Options:

Section 3-7 Non-Harmonics Signal Test (All MG369xB Models)

Part 1 (Sheet 1 of 3)

MG369xB Frequency (GHz)	MG369xB Output Power Level ⁽¹⁾	Spectrum Analyzer Start Frequency (GHz)	Spectrum Analyzer Stop Frequency (GHz)	Spectrum Analyzer RBW (kHz)	Test Result (dBc)	Spec. (dBc)	Measurement Uncertainty (dB)
2.650	10dBm	2.649	2.651	30.000		n/a	n/a
2.650	10dBm	2.645	2.649	30.000		-60	2.26
2.650	10dBm	2.595	2.645	100.000		-60	2.34
2.650	10dBm	2.350	2.595	100.000		-60	2.34
2.650	10dBm	2.651	2.655	30.000		-60	2.26
2.650	10dBm	2.655	2.705	100.000		-60	2.34
2.650	10dBm	2.705	2.950	100.000		-60	2.93
2.650	10dBm	2.000	2.350	100.000		-60	2.34
2.650	10dBm	2.950	5.000	100.000		-60	2.93
2.650	10dBm	5.600	7.650	100.000		-60	3.33
2.650	10dBm	8.250	10.300	100.000		-60	3.33
2.650	10dBm	10.900	12.950	100.000		-60	3.33
2.650	10dBm	13.550	16.775	30.000		-60	3.24
2.650	10dBm	16.775	20.000	30.000		-60	3.24
4.400	10dBm	4.399	4.401	30.000		n/a	n/a
4.400	10dBm	4.395	4.399	30.000		-60	2.97
4.400	10dBm	4.345	4.395	100.000		-60	3.02
4.400	10dBm	4.100	4.345	100.000		-60	3.02
4.400	10dBm	4.401	4.405	30.000		-60	2.97
4.400	10dBm	4.405	4.455	100.000		-60	3.02
4.400	10dBm	4.455	4.700	100.000		-60	3.02
4.400	10dBm	2.500	3.000	100.000		-60	2.93
4.400	10dBm	3.600	4.100	100.000		-60	3.02
4.400	10dBm	4.700	8.500	100.000		-60	3.53
4.400	10dBm	9.100	12.900	100.000		-60	3.53
4.400	10dBm	13.500	17.300	30.000		-60	3.46
4.400	10dBm	17.900	20.000	30.000		-60	3.46
6.950	10dBm	6.949	6.951	30.000		n/a	n/a
6.950	10dBm	6.945	6.949	30.000		-60	3.66
6.950	10dBm	6.895	6.945	100.000		-60	3.69
6.950	10dBm	6.650	6.895	100.000		-60	3.69
6.950	10dBm	6.951	6.955	30.000		-60	3.66

Test Records

MG369__B	Firmware Revision:	Operator:
Serial Number:	Date:	Options:

Section 3-7 Non-Harmonics Signal Test (All MG369xB Models)

Part 1 (Sheet 2 of 3)

MG369xB Frequency (GHz)	MG369xB Output Power Level ⁽¹⁾	Spectrum Analyzer Start Frequency (GHz)	Spectrum Analyzer Stop Frequency (GHz)	Spectrum Analyzer RBW (kHz)	Test Result (dBc)	Spec. (dBc)	Measurement Uncertainty (dB)
6.950	10dBm	6.955	7.005	100.000		-60	3.69
6.950	10dBm	7.005	7.250	100.000		-60	3.69
6.950	10dBm	2.000	2.017	100.000		-60	3.33
6.950	10dBm	2.617	3.175	100.000		-60	3.53
6.950	10dBm	3.775	4.913	100.000		-60	3.53
6.950	10dBm	5.513	6.650	100.000		-60	3.69
6.950	10dBm	7.250	10.500	30.000		-60	3.66
6.950	10dBm	10.500	13.600	30.000		-60	3.78
6.950	10dBm	14.200	17.000	30.000		-60	3.75
6.950	10dBm	17.000	20.000	30.000		-60	3.75
10.950	10dBm	10.949	10.951	30.000		n/a	n/a
10.950	10dBm	10.945	10.949	30.000		-60	3.66
10.950	10dBm	10.895	10.945	30.000		-60	3.66
10.950	10dBm	10.650	10.895	30.000		-60	3.66
10.950	10dBm	10.951	10.955	30.000		-60	3.66
10.950	10dBm	10.955	11.005	30.000		-60	3.66
10.950	10dBm	11.005	11.250	30.000		-60	3.66
10.950	10dBm	2.000	3.350	30.000		-60	3.49
10.950	10dBm	3.950	5.175	30.000		-60	3.49
10.950	10dBm	5.775	7.913	30.000		-60	3.49
10.950	10dBm	8.512	10.650	30.000		-60	3.66
10.950	10dBm	11.250	15.500	10.000		-60	3.81
10.950	10dBm	15.500	20.000	10.000		-60	3.78
16.750	10dBm	16.749	16.751	30.000		n/a	n/a
16.750	10dBm	16.745	16.749	30.000		-60	3.59
16.750	10dBm	16.695	16.745	30.000		-60	3.59
16.750	10dBm	16.450	16.695	30.000		-60	3.59
16.750	10dBm	16.751	16.755	30.000		-60	3.59
16.750	10dBm	16.755	16.805	30.000		-60	3.59
16.750	10dBm	16.805	17.050	30.000		-60	3.59
16.750	10dBm	2.000	5.283	30.000		-60	3.46
16.750	10dBm	5.883	8.075	30.000		-60	3.75
16.750	10dBm	8.675	12.263	30.000		-60	3.75

MG369__B	Firmware Revision:	Operator:
Serial Number:	Date:	Options:

Section 3-7 Non-Harmonics Signal Test (All MG369xB Models)

Part 1 (Sheet 3 of 3)

MG369xB Frequency (GHz)	MG369xB Output Power Level ⁽¹⁾	Spectrum Analyzer Start Frequency (GHz)	Spectrum Analyzer Stop Frequency (GHz)	Spectrum Analyzer RBW (kHz)	Test Result (dBc)	Spec. (dBc)	Measurement Uncertainty (dB)
16.750	10dBm	12.863	16.450	10.000		-60	3.78
16.750	10dBm	17.050	20.000	10.000		-60	3.63

1. All specifications apply at the lesser of +10 dBm output or Maximum specified leveled output power, unless otherwise noted.

Test Records

MG369__B	Firmware Revision:	Operator:
Serial Number:	Date:	Options:

Section 3-7 Non-Harmonics Signal Test (All MG369xB Models)

Part 2 (Sheet 1 of 2)

MG369xB Freq. (GHz)	MG369xB Output Power Level ⁽¹⁾	Spectrum Analyzer Center Freq. (GHz)	Spectrum Analyzer Span	Spectrum Analyzer RBW	Test Result (dBc)	Specification (dBc)	Measurement Uncertainty (dB)	Exclusions
1.100000 ⁽²⁾	10 dBm	1.100000	1 MHz	30 kHz	n/a	n/a	n/a	
1.100000 ⁽²⁾	10 dBm	1.500000	1 MHz	30 kHz		-60 (opt. 4 units) -40 (opt. 5 units)	2.26	
1.100000 ⁽²⁾	10 dBm	0.500000	1 MHz	30 kHz		-60 (opt. 4 units) -40 (opt. 5 units)	2.26	
1.100000 ⁽²⁾	10 dBm	2.000000	1 MHz	30 kHz		-60 (opt. 4 units) -40 (opt. 5 units)	2.26	
1.100000 ⁽²⁾	10 dBm	6.500000	1 MHz	30 kHz		-60 (opt. 4 units) -40 (opt. 5 units)	2.54	
1.100000 ⁽²⁾	10 dBm	7.600000	1 MHz	30 kHz		-60 (opt. 4 units) -40 (opt. 5 units)	2.54	
20.001000	(3)	20.001000	1 MHz	10 kHz	n/a	n/a	n/a	Test not performed on MG3691B and MG3692B
20.001000	(3)	40.000000	1 MHz	10 kHz		-60	3.92	Test not performed on MG3691B and MG3692B
24.999000	(3)	24.999000	1 MHz	10 kHz	n/a	n/a	n/a	Test not performed on MG3691B and MG3692B
24.999000	(3)	45.800000	1 MHz	10 kHz		-60	3.92	Test not performed on MG3691B and MG3692B
24.999000	(3)	49.667000	1 MHz	10 kHz		-60	3.92	Test not performed on MG3691B and MG3692B
25.001000	(3)	25.001000	1 MHz	10 kHz	n/a	n/a	n/a	Test not performed on MG3691B and MG3692B
25.001000	(3)	49.799800	1 MHz	10 kHz		-60	4.13	Test not performed on MG3691B and MG3692B
31.886891	(3)	31.886891	1 MHz	10 kHz	n/a	n/a	n/a	Test not performed on MG3691B, MG3692B and MG3693B
31.886891	(3)	26.246891	1 MHz	10 kHz		-60	4.13	Test not performed on MG3691B, MG3692B and MG3693B

MG369__B	Firmware Revision:	Operator:
Serial Number:	Date:	Options:

Section 3-7 Non-Harmonics Signal Test (All MG369xB Models)

Part 2 (Sheet 2 of 2)

MG369xB Freq. (GHz)	MG369xB Output Power Level ⁽¹⁾	Spectrum Analyzer Center Freq. (GHz)	Spectrum Analyzer Span	Spectrum Analyzer RBW	Test Result (dBc)	Specification (dBc)	Measurement Uncertainty (dB)	Exclusions
32.892580	(3)	32.892580	1 MHz	10 kHz	n/a	n/a	n/a	Test not performed on MG3691B, MG3692B and MG3693B
32.892580	(3)	28.555738	1 MHz	10 kHz		-60	4.08	Test not performed on MG3691B, MG3692B and MG3693B
39.999000	(3)	39.999000	1 MHz	10 kHz	n/a	n/a	n/a	Test not performed on MG3691B, MG3692B and MG3693B
39.999000	(3)	36.515522	1 MHz	10 kHz		-60	4.01	Test not performed on MG3691B, MG3692B and MG3693B
40.001000	(3)	40.001000	1 MHz	10 kHz	n/a	n/a	n/a	Test not performed on MG3691B, MG3692B, MG3693B and MG3694B
40.001000	(3)	39.935300	1 MHz	10 kHz		-60	4.01	Test not performed on MG3691B, MG3692B, MG3693B and MG3694B
43.634869	(3)	43.634869	1 MHz	10 kHz	n/a	n/a	n/a	
43.634869	(3)	43.723037	1 MHz	10 kHz		-60	4.01	
49.999000	(3)	49.999000	1 MHz	10 kHz	n/a	n/a	n/a	
49.999000	(3)	44.215923	1 MHz	3 kHz		-60	4.04	

1. All specifications apply at the lesser of +10 dBm output or Maximum specified leveled output power, unless otherwise noted.
2. Only performed on units with option 4 or 5.
3. Dependent on maximum leveled power by options and model number. See footnote tables on the following page.

Test Records

MG369__B	Firmware Revision:	Operator:
Serial Number:	Date:	Options:

Section 3-7 Non-Harmonics Signal Test (All MG369xB Models)

Reference

Footnote 3: Table 1, Option 15 not Installed

Units with Option 15 not installed, frequency range from 20 GHz to maximum frequency of model. For output power with Option 22 derate all specifications by 2 dB.

Model	Output Power (dBm)	Output Power with Step Attenuator (opt 2X) installed (dBm)	Output Power with Electronic Step Attenuator (opt 2E) Installed (dBm)
MG3691B	+10	+10	+10
MG3692B	+10	+10	Not available
MG3693B	+6	+3	Not available
MG3694B	+6	+3	Not available
MG3695B	+3	0	Not available
MG3696B	+3	0 (typical 60–67 GHz)	Not available

Footnote 3: Table 2, Option 15 Installed

Units with Option 15 installed, frequency range from 20 GHz to maximum frequency of model. For output power with Option 22 derate all specifications by 2 dB.

Model	Freq Range List if Not < 2 GHz to 20 GHz	Notes	Output Power (dBm)	Output Power with Step Attenuator (opt 2X) Installed (dBm)	Output power with Electronic Step Attenuator (opt 2E) Installed (dBm)
MG3691B	< 2 GHz to 10 GHz		+10	+10	+10
MG3692B	< 2 GHz to 20 GHz		+10	+10	N/A
MG3693B	< 2 GHz to 30 GHz		+10	+10	Not available
MG3694B	< 2 GHz to 40 GHz		+10	+10	Not available
MG3695B	> 20 GHz to ≤ 40 GHz	w/ opt. 4 or 5	+10	+10	Not available
MG3695B	> 40 GHz to ≤ 50 GHz	w/ opt. 4 or 5	+10	+8	Not available
MG3695B	> 20 GHz to ≤ 50 GHz	w/o opt. 4 or 5	+10	+10	Not available
MG3696B	> 20 GHz to ≤ 40 GHz	w/ opt. 4 or 5	+10	+10	Not available
MG3696B	> 40 GHz to ≤ 67 GHz	w/ opt. 4 or 5	+6	+6	Not available
MG3696B	> 67 GHz to ≤ 70 GHz	w/ opt. 4 or 5	+3 (typical)	0 (typical)	Not available
MG3696B	> 20 GHz to ≤ 40 GHz	w/o opt. 4 or 5	+10	+10	Not available
MG3696B	> 40 GHz to ≤ 67 GHz	w/o opt. 4 or 5	+9	+6 (typical)	Not available
MG3696B	> 67 GHz to ≤ 70 GHz	w/o opt. 4 or 5	+3 (typical)	0 (typical)	Not available

MG369__B	Firmware Revision:	Operator:
Serial Number:	Date:	Options:

Section 3-8 Single Sideband Phase Noise Test with Agilent E5052B Signal Source Analyzer and E5053A Down Converter

All MG369xB Models without Options 3 or 30 Single Sideband Phase Noise (Sheet 1 of 2)

Frequency Offset	Measured Value (dBc)	Upper Limit (dBc)	Measurement Uncertainty (dB)
Test Frequency: 15.0 MHz (Models with Option 4 Only)			
100 Hz		-94	2.38
1 kHz		-106	2.0
10 kHz		-104	2.0
100 kHz		-120	2.0
Test Frequency: 60.0 MHz (Models with Option 4 Only)			
100 Hz		-94	2.38
1 kHz		-106	2.0
10 kHz		-104	2.0
100 kHz		-120	2.0
Test Frequency: 499 MHz (Models with Option 4 Only)			
100 Hz		-94	2.38
1 kHz		-106	2.0
10 kHz		-104	2.0
100 kHz		-120	2.0
Test Frequencies: 600 MHz (Models with Option 5 Only)			
100 Hz		-77	2.38
1 kHz		-88	2.0
10 kHz		-85	2.0
100 kHz		-100	2.0
Test Frequencies: 1.99 GHz (Models with Option 5 Only)			
100 Hz		-77	2.38
1 kHz		-88	2.0
10 kHz		-85	2.0
100 kHz		-100	2.0
Test Frequency: 2.01 GHz (Models without Option 4 Only)			
100 Hz		-77	2.38
1 kHz		-88	2.0
10 kHz		-86	2.0
100 kHz		-102	2.0

Test Records

MG369__B	Firmware Revision:	Operator:
Serial Number:	Date:	Options:

Section 3-8 Single Sideband Phase Noise Test with Agilent E5052B Signal Source Analyzer and E5053A Down Converter

All MG369xB Models without Options 3 or 30 Single Sideband Phase Noise (Sheet 2 of 2)

Frequency Offset	Measured Value (dBc)	Upper Limit (dBc)	Measurement Uncertainty (dB)
Test Frequency: 2.19 GHz (Models with Option 4 Only)			
100 Hz		-82	2.38
1 kHz		-94	2.0
10 kHz		-92	2.0
100 kHz		-108	2.0
Test Frequency: 6.0 GHz			
100 Hz		-77	2.38
1 kHz		-88	2.0
10 kHz		-86	2.0
100 kHz		-102	2.0
Test Frequency: 10.0 GHz (8 GHz for MG3691B)			
100 Hz		-73	2.38
1 kHz		-86	2.0
10 kHz		-83	2.0
100 kHz		-102	2.0
Test Frequency: 19.99 GHz (not performed on MG3691B)			
100 Hz		-66	2.38
1 kHz		-78	2.0
10 kHz		-77	2.0
100 kHz		-100	2.0
Test Frequency: 20.01 GHz (not performed on MG3691B or MG3692B)			
100 Hz		-60	2.38
1 kHz		-75	2.0
10 kHz		-72	2.0
100 kHz		-94	2.0
Test Frequency: 25.0 GHz (not performed on MG3691B or MG3692B)			
100 Hz		-60	2.38
1 kHz		-75	2.0
10 kHz		-72	2.0
100 kHz		-94	2.0

MG369__B	Firmware Revision:	Operator:
Serial Number:	Date:	Options:

Section 3-8 Single Sideband Phase Noise Test with Agilent E5052B Signal Source Analyzer and E5053A Down Converter

All MG369xB Models with Option 3 (Sheet 1 of 4)

Frequency Offset	Measured Value (dBc)	Upper Limit (dBc)	Measurement Uncertainty (dB)
Test Frequency: 15 MHz (Models with Option 4 Only)			
10 Hz		-105	3.07
100 Hz		-126	2.38
1 kHz		-139	2.0
10 kHz		-142	2.0
100 kHz		-141	2.0
1 MHz		-145	2.0
Test Frequency: 30 MHz (Models with Option 4 Only)			
10 Hz		-99	3.07
100 Hz		-120	2.38
1 kHz		-134	2.0
10 kHz		-137	2.0
100 kHz		-137	2.0
1 MHz		-145	2.0
Test Frequency: 60 MHz (Models with Option 4 Only)			
10 Hz		-90	3.07
100 Hz		-114	2.38
1 kHz		-129	2.0
10 kHz		-136	2.0
100 kHz		-136	2.0
1 MHz		-144	2.0
Test Frequency: 120 MHz (Models with Option 4 Only)			
10 Hz		-88	3.07
100 Hz		-108	2.38
1 kHz		-127	2.0
10 kHz		-135	2.0
100 kHz		-133	2.0
1 MHz		-144	2.0

Test Records

MG369__B	Firmware Revision:	Operator:
Serial Number:	Date:	Options:

Section 3-8 Single Sideband Phase Noise Test with Agilent E5052B Signal Source Analyzer and E5053A Down Converter

All MG369xB Models with Option 3 (Sheet 2 of 4)

Frequency Offset	Measured Value (dBc)	Upper Limit (dBc)	Measurement Uncertainty (dB)
Test Frequency: 250 MHz (Models with Option 4 Only)			
10 Hz		-84	3.07
100 Hz		-102	2.38
1 kHz		-125	2.0
10 kHz		-132	2.0
100 kHz		-130	2.0
1 MHz		-143	2.0
Test Frequency: 499 MHz (Models with Option 4 Only)			
10 Hz		-77	3.07
100 Hz		-99	2.38
1 kHz		-123	2.0
10 kHz		-125	2.0
100 kHz		-124	2.0
1 MHz		-142	2.0
Test Frequencies: 600 MHz (Models with Option 5 Only)			
10 Hz		-64	3.07
100 Hz		-83	2.38
1 kHz		-100	2.0
10 kHz		-102	2.0
100 kHz		-102	2.0
1 MHz		-111	2.0
Test Frequencies: 1.99 GHz (Models with Option 5 Only)			
10 Hz		-64	3.07
100 Hz		-83	2.38
1 kHz		-100	2.0
10 kHz		-102	2.0
100 kHz		-102	2.0
1 MHz		-111	2.0

MG369__B	Firmware Revision:	Operator:
Serial Number:	Date:	Options:

Section 3-8 Single Sideband Phase Noise Test with Agilent E5052B Signal Source Analyzer and E5053A Down Converter

All MG369xB Models with Option 3 (Sheet 3 of 4)

Frequency Offset	Measured Value (dBc)	Upper Limit (dBc)	Measurement Uncertainty (dB)
Test Frequency: 2.01 GHz (Models without Option 4 Only)			
10 Hz		-54	3.07
100 Hz		-77	2.38
1 kHz		-104	2.0
10 kHz		-108	2.0
100 kHz		-107	2.0
1 MHz		-130	2.0
Test Frequency: 2.19 GHz (Models with Option 4 Only)			
10 Hz		-66	3.07
100 Hz		-86	2.38
1 kHz		-112	2.0
10 kHz		-115	2.0
100 kHz		-113	2.0
1 MHz		-135	2.0
Test Frequency: 6.0 GHz			
10 Hz		-54	3.07
100 Hz		-77	2.38
1 kHz		-104	2.0
10 kHz		-108	2.0
100 kHz		-107	2.0
1 MHz		-130	2.0
Test Frequency: 10.0 GHz (8 GHz for MG3691B)			
10 Hz		-52	3.07
100 Hz		-73	2.38
1 kHz		-100	2.0
10 kHz		-107	2.0
100 kHz		-107	2.0
1 MHz		-128	2.0

Test Records

MG369__B	Firmware Revision:	Operator:
Serial Number:	Date:	Options:

Section 3-8 Single Sideband Phase Noise Test with Agilent E5052B Signal Source Analyzer and E5053A Down Converter

All MG369xB Models with Option 3 (Sheet 4 of 4)

Frequency Offset	Measured Value (dBc)	Upper Limit (dBc)	Measurement Uncertainty (dB)
Test Frequency: 19.99 GHz (not performed on MG3691B)			
10 Hz		-45	3.07
100 Hz		-68	2.38
1 kHz		-94	2.0
10 kHz		-102	2.0
100 kHz		-102	2.0
1 MHz		-125	2.0
Test Frequency: 20.01 GHz (not performed on MG3691B or MG3692B)			
10 Hz		-45	3.07
100 Hz		-63	2.38
1 kHz		-92	2.0
10 kHz		-98	2.0
100 kHz		-98	2.0
1 MHz		-119	2.0
Test Frequency: 25.0 GHz (not performed on MG3691B or MG3692B)			
10 Hz		-45	3.07
100 Hz		-63	2.38
1 kHz		-92	2.0
10 kHz		-98	2.0
100 kHz		-98	2.0
1 MHz		-119	2.0

MG369__B	Firmware Revision:	Operator:
Serial Number:	Date:	Options:

Section 3-8 Single Sideband Phase Noise Test with Agilent E5052B Signal Source Analyzer and E5053A Down Converter
 All MG369xB Models with Option 30 (Sheet 1 of 3)

Frequency Offset	Measured Value (dBc)	Upper Limit (dBc)	Measurement Uncertainty (dB)
Test Frequency: 15 MHz (Models with Option 4 Only)			
10 Hz		-77	3.07
100 Hz		-99	2.38
1 kHz		-110	2.0
10 kHz		-110	2.0
100 kHz		-122	2.0
1 MHz		-142	2.0
Test Frequency: 60 MHz (Models with Option 4 Only)			
10 Hz		-77	3.07
100 Hz		-99	2.38
1 kHz		-110	2.0
10 kHz		-110	2.0
100 kHz		-122	2.0
1 MHz		-142	2.0
Test Frequency: 499 MHz (Models with Option 4 Only)			
10 Hz		-77	3.07
100 Hz		-99	2.38
1 kHz		-110	2.0
10 kHz		-110	2.0
100 kHz		-122	2.0
1 MHz		-142	2.0
Test Frequencies: 600 MHz (Models with Option 5 Only)			
10 Hz		-64	3.07
100 Hz		-83	2.38
1 kHz		-93	2.0
10 kHz		-93	2.0
100 kHz		-100	2.0
1 MHz		-111	2.0

Test Records

MG369__B	Firmware Revision:	Operator:
Serial Number:	Date:	Options:

Section 3-8 Single Sideband Phase Noise Test with Agilent E5052B Signal Source Analyzer and E5053A Down Converter All MG369xB Models with Option 30 (Sheet 2 of 3)

Frequency Offset	Measured Value (dBc)	Upper Limit (dBc)	Measurement Uncertainty (dB)
Test Frequencies: 1.99 GHz (Models with Option 5 Only)			
10 Hz		-64	3.07
100 Hz		-83	2.38
1 kHz		-93	2.0
10 kHz		-93	2.0
100 kHz		-100	2.0
1 MHz		-111	2.0
Test Frequency: 2.01 GHz (Models without Option 4 Only)			
10 Hz		-54	3.07
100 Hz		-77	2.38
1 kHz		-93	2.0
10 kHz		-93	2.0
100 kHz		-102	2.0
1 MHz		-130	2.0
Test Frequency: 2.19 GHz (Models with Option 4 Only)			
10 Hz		-64	3.07
100 Hz		-86	2.38
1 kHz		-98	2.0
10 kHz		-98	2.0
100 kHz		-110	2.0
1 MHz		-135	2.0
Test Frequency: 6.0 GHz			
10 Hz		-52	3.07
100 Hz		-73	2.38
1 kHz		-93	2.0
10 kHz		-93	2.0
100 kHz		-105	2.0
1 MHz		-128	2.0

MG369__B	Firmware Revision:	Operator:
Serial Number:	Date:	Options:

**Section 3-8 Single Sideband Phase Noise Test with
Agilent E5052B Signal Source Analyzer and E5053A Down Converter
All MG369xB Models with Option 30 (Sheet 3 of 3)**

Frequency Offset	Measured Value (dBc)	Upper Limit (dBc)	Measurement Uncertainty (dB)
Test Frequency: 10.0 GHz (8 GHz for MG3691B)			
10 Hz		-52	3.07
100 Hz		-73	2.38
1 kHz		-93	2.0
10 kHz		-93	2.0
100 kHz		-105	2.0
1 MHz		-128	2.0
Test Frequency: 19.99 GHz (not performed on MG3691B)			
10 Hz		-45	3.07
100 Hz		-68	2.38
1 kHz		-86	2.0
10 kHz		-86	2.0
100 kHz		-100	2.0
1 MHz		-125	2.0
Test Frequency: 20.01 GHz (not performed on MG3691B or MG3692B)			
10 Hz		-45	3.07
100 Hz		-63	2.38
1 kHz		-80	2.0
10 kHz		-80	2.0
100 kHz		-94	2.0
1 MHz		-119	2.0
Test Frequency: 25.0 GHz (not performed on MG3691B or MG3692B)			
10 Hz		-45	3.07
100 Hz		-63	2.38
1 kHz		-80	2.0
10 kHz		-80	2.0
100 kHz		-94	2.0
1 MHz		-119	2.0

Test Records

MG369__B	Firmware Revision:	Operator:
Serial Number:	Date:	Options:

Section 3-8 Single Sideband Phase Noise Test: Power Line and Fan Rotation Emissions with Agilent E5052B Signal Source Analyzer and E5053A Down Converter

All MG369xB Models (Sheet 1 of 3)

Frequency Offset	Measured Value (dBc)	Upper Limit (dBc)	Measurement Uncertainty (dB)
Test Frequency: 15 MHz (Models with Options 4 and 3 Only)			
< 300 Hz		-68	3.07
300 Hz to 1 kHz		-72	2.38
> 1 kHz		-72	2.0
Test Frequency: 30 MHz (Models with Option 4 Only)			
< 300 Hz		-68	3.07
300 Hz to 1 kHz		-72	2.38
> 1 kHz		-72	2.0
Test Frequency: 60 MHz (Models with Options 4 and 3 Only)			
< 300 Hz		-68	3.07
300 Hz to 1 kHz		-72	2.38
> 1 kHz		-72	2.0
Test Frequency: 120 MHz (Models with Options 4 and 3 Only)			
< 300 Hz		-68	3.07
300 Hz to 1 kHz		-72	2.38
> 1 kHz		-72	2.0
Test Frequency: 250 MHz (Models with Option 4 Only)			
< 300 Hz		-68	3.07
300 Hz to 1 kHz		-72	2.38
> 1 kHz		-72	2.0
Test Frequency: 499 MHz (Models with Option 4 Only)			
< 300 Hz		-68	3.07
300 Hz to 1 kHz		-72	2.38
> 1 kHz		-72	2.0
Test Frequencies: 600 MHz (Models with Option 5 Only)			
< 300 Hz		-50	3.07
300 Hz to 1 kHz		-60	2.38
> 1 kHz		-60	2.0

MG369__B	Firmware Revision:	Operator:
Serial Number:	Date:	Options:

Section 3-8 Single Sideband Phase Noise Test: Power Line and Fan Rotation Emissions with Agilent E5052B Signal Source Analyzer and E5053A Down Converter

All MG369xB Models (Sheet 2 of 3)

Frequency Offset	Measured Value (dBc)	Upper Limit (dBc)	Measurement Uncertainty (dB)
Test Frequencies: 1.99 GHz (Models with Option 5 Only)			
< 300 Hz		-50	3.07
300 Hz to 1 kHz		-60	2.38
> 1 kHz		-60	2.0
Test Frequency: 2.01 GHz (Models without Option 4 Only)			
< 300 Hz		-50	3.07
300 Hz to 1 kHz		-60	2.38
> 1 kHz		-60	2.0
Test Frequency: 2.19 GHz (Models with Option 4 Only)			
< 300 Hz		-56	3.07
300 Hz to 1 kHz		-66	2.38
> 1 kHz		-66	2.0
Test Frequency: 6.0 GHz			
< 300 Hz		-50	3.07
300 Hz to 1 kHz		-60	2.38
> 1 kHz		-60	2.0
Test Frequency: 10.0 GHz (8 GHz for MG3691B)			
< 300 Hz		-46	3.07
300 Hz to 1 kHz		-56	2.38
> 1 kHz		-60	2.0
Test Frequency: 19.99 GHz (not performed on MG3691B)			
< 300 Hz		-46	3.07
300 Hz to 1 kHz		-56	2.38
> 1 kHz		-60	2.0
Test Frequency: 20.01 GHz (not performed on MG3691B or MG3692B)			
< 300 Hz		-40	3.07
300 Hz to 1 kHz		-50	2.38
> 1 kHz		-54	2.0

Test Records

MG369__B	Firmware Revision:	Operator:
Serial Number:	Date:	Options:

Section 3-8 Single Sideband Phase Noise Test: Power Line and Fan Rotation Emissions with Agilent E5052B Signal Source Analyzer and E5053A Down Converter

All MG369xB Models (Sheet 3 of 3)

Frequency Offset	Measured Value (dBc)	Upper Limit (dBc)	Measurement Uncertainty (dB)
Test Frequency: 25.0 GHz (not performed on MG3691B or MG3692B)			
< 300 Hz		-40	3.07
300 Hz to 1 kHz		-50	2.38
> 1 kHz		-54	2.0

MG369__B	Firmware Revision:	Operator:
Serial Number:	Date:	Options:

Section 3-8 Single Sideband Phase Noise Test with AeroFlex PN9000 Phase Noise System

All MG369xB Models without Options 3 or 30 Single Sideband Phase Noise (Sheet 1 of 2)

Frequency Offset	Measured Value (dBc)	Upper Limit (dBc)	Measurement Uncertainty (dB)
Test Frequency: 15.0 MHz (Models with Option 4 Only)			
100 Hz		-94	2.5
1 kHz		-106	2.5
10 kHz		-104	2.5
100 kHz		-120	2.5
Test Frequency: 60.0 MHz (Models with Option 4 Only)			
100 Hz		-94	2.5
1 kHz		-106	2.5
10 kHz		-104	2.5
100 kHz		-120	2.5
Test Frequency: 499 MHz (Models with Option 4 Only)			
100 Hz		-94	2.5
1 kHz		-106	2.5
10 kHz		-104	2.5
100 kHz		-120	2.5
Test Frequencies: 600 MHz (Models with Option 5 Only)			
100 Hz		-77	2.5
1 kHz		-88	2.5
10 kHz		-85	2.5
100 kHz		-100	2.5
Test Frequencies: 1.99 GHz (Models with Option 5 Only)			
100 Hz		-77	2.5
1 kHz		-88	2.5
10 kHz		-85	2.5
100 kHz		-100	2.5
Test Frequency: 2.01 GHz (Models without Option 4 Only)			
100 Hz		-77	2.5
1 kHz		-88	2.5
10 kHz		-86	2.5
100 kHz		-102	2.5

Test Records

MG369__B	Firmware Revision:	Operator:
Serial Number:	Date:	Options:

Section 3-8 Single Sideband Phase Noise Test with AeroFlex PN9000 Phase Noise System

All MG369xB Models without Options 3 or 30 Single Sideband Phase Noise (Sheet 2 of 2)

Frequency Offset	Measured Value (dBc)	Upper Limit (dBc)	Measurement Uncertainty (dB)
Test Frequency: 2.19 GHz (Models with Option 4 Only)			
100 Hz		-82	2.5
1 kHz		-94	2.5
10 kHz		-92	2.5
100 kHz		-108	2.5
Test Frequency: 6.0 GHz			
100 Hz		-77	2.5
1 kHz		-88	2.5
10 kHz		-86	2.5
100 kHz		-102	2.5
Test Frequency: 10.0 GHz (8 GHz for MG3691B)			
100 Hz		-73	2.5
1 kHz		-86	2.5
10 kHz		-83	2.5
100 kHz		-102	2.5
Test Frequency: 19.99 GHz (not performed on MG3691B)			
100 Hz		-66	2.5
1 kHz		-78	2.5
10 kHz		-77	2.5
100 kHz		-100	2.5
Test Frequency: 20.01 GHz (not performed on MG3691B or MG3692B)			
100 Hz		-60	2.5
1 kHz		-75	2.5
10 kHz		-72	2.5
100 kHz		-94	2.5
Test Frequency: 25.0 GHz (not performed on MG3691B or MG3692B)			
100 Hz		-60	2.5
1 kHz		-75	2.5
10 kHz		-72	2.5
100 kHz		-94	2.5

MG369__B	Firmware Revision:	Operator:
Serial Number:	Date:	Options:

Section 3-8 Single Sideband Phase Noise Test with AeroFlex PN9000 Phase Noise System

All MG369xB Models with Option 3 (Sheet 1 of 4)

Frequency Offset	Measured Value (dBc)	Upper Limit (dBc)	Measurement Uncertainty (dB)
Test Frequency: 15 MHz (Models with Option 4 Only)			
10 Hz ⁽¹⁾		-105	2.5
100 Hz		-126	2.5
1 kHz		-139	2.5
10 kHz		-142	2.5
100 kHz		-141	2.5
1 MHz		-145	2.5
Test Frequency: 30 MHz (Models with Option 4 Only)			
10 Hz ⁽¹⁾		-99	2.5
100 Hz		-120	2.5
1 kHz		-134	2.5
10 kHz		-137	2.5
100 kHz		-137	2.5
1 MHz		-145	2.5
Test Frequency: 60 MHz (Models with Option 4 Only)			
10 Hz ⁽¹⁾		-90	2.5
100 Hz		-114	2.5
1 kHz		-129	2.5
10 kHz		-136	2.5
100 kHz		-136	2.5
1 MHz		-144	2.5
Test Frequency: 120 MHz (Models with Option 4 Only)			
10 Hz ⁽¹⁾		-88	2.5
100 Hz		-108	2.5
1 kHz		-127	2.5
10 kHz		-135	2.5
100 kHz		-133	2.5
1 MHz		-144	2.5

Test Records

MG369__B	Firmware Revision:	Operator:
Serial Number:	Date:	Options:

Section 3-8 Single Sideband Phase Noise Test with AeroFlex PN9000 Phase Noise System

All MG369xB Models with Option 3 (Sheet 2 of 4)

Frequency Offset	Measured Value (dBc)	Upper Limit (dBc)	Measurement Uncertainty (dB)
Test Frequency: 250 MHz (Models with Option 4 Only)			
10 Hz ⁽¹⁾		-84	2.5
100 Hz		-102	2.5
1 kHz		-125	2.5
10 kHz		-132	2.5
100 kHz		-130	2.5
1 MHz		-143	2.5
Test Frequency: 499 MHz (Models with Option 4 Only)			
10 Hz ⁽¹⁾		-77	2.5
100 Hz		-99	2.5
1 kHz		-123	2.5
10 kHz		-125	2.5
100 kHz		-124	2.5
1 MHz		-142	2.5
Test Frequencies: 600 MHz (Models with Option 5 Only)			
10 Hz ⁽¹⁾		-64	2.5
100 Hz		-83	2.5
1 kHz		-100	2.5
10 kHz		-102	2.5
100 kHz		-102	2.5
1 MHz		-111	2.5
Test Frequencies: 1.99 GHz (Models with Option 5 Only)			
10 Hz ⁽¹⁾		-64	2.5
100 Hz		-83	2.5
1 kHz		-100	2.5
10 kHz		-102	2.5
100 kHz		-102	2.5
1 MHz		-111	2.5

MG369__B	Firmware Revision:	Operator:
Serial Number:	Date:	Options:

Section 3-8 Single Sideband Phase Noise Test with AeroFlex PN9000 Phase Noise System

All MG369xB Models with Option 3 (Sheet 3 of 4)

Frequency Offset	Measured Value (dBc)	Upper Limit (dBc)	Measurement Uncertainty (dB)
Test Frequency: 2.01 GHz (Models without Option 4 Only)			
10 Hz ⁽¹⁾		-54	2.5
100 Hz		-77	2.5
1 kHz		-104	2.5
10 kHz		-108	2.5
100 kHz		-107	2.5
1 MHz		-130	2.5
Test Frequency: 2.19 GHz (Models with Option 4 Only)			
10 Hz ⁽¹⁾		-66	2.5
100 Hz		-86	2.5
1 kHz		-112	2.5
10 kHz		-115	2.5
100 kHz		-113	2.5
1 MHz		-135	2.5
Test Frequency: 6.0 GHz			
10 Hz ⁽¹⁾		-54	2.5
100 Hz		-77	2.5
1 kHz		-104	2.5
10 kHz		-108	2.5
100 kHz		-107	2.5
1 MHz		-130	2.5
Test Frequency: 10.0 GHz (8 GHz for MG3691B)			
10 Hz ⁽¹⁾		-52	2.5
100 Hz		-73	2.5
1 kHz		-100	2.5
10 kHz		-107	2.5
100 kHz		-107	2.5
1 MHz		-128	2.5

Test Records

MG369__B	Firmware Revision:	Operator:
Serial Number:	Date:	Options:

Section 3-8 Single Sideband Phase Noise Test with AeroFlex PN9000 Phase Noise System

All MG369xB Models with Option 3 (Sheet 4 of 4)

Frequency Offset	Measured Value (dBc)	Upper Limit (dBc)	Measurement Uncertainty (dB)
Test Frequency: 19.99 GHz (not performed on MG3691B)			
10 Hz ⁽¹⁾		-45	2.5
100 Hz		-68	2.5
1 kHz		-94	2.5
10 kHz		-102	2.5
100 kHz		-102	2.5
1 MHz		-125	2.5
Test Frequency: 20.01 GHz (not performed on MG3691B or MG3692B)			
10 Hz ⁽¹⁾		-45	2.5
100 Hz		-63	2.5
1 kHz		-92	2.5
10 kHz		-98	2.5
100 kHz		-98	2.5
1 MHz		-119	2.5
Test Frequency: 25.0 GHz (not performed on MG3691B or MG3692B)			
10 Hz ⁽¹⁾		-45	2.5
100 Hz		-63	2.5
1 kHz		-92	2.5
10 kHz		-98	2.5
100 kHz		-98	2.5
1 MHz		-119	2.5

1. On some AeroFlex Test Stations 10 Hz is not reported so use 10.23 Hz.

MG369__B	Firmware Revision:	Operator:
Serial Number:	Date:	Options:

Section 3-8 Single Sideband Phase Noise Test with AeroFlex PN9000 Phase Noise System

All MG369xB Models with Option 30 (Sheet 1 of 3)

Frequency Offset	Measured Value (dBc)	Upper Limit (dBc)	Measurement Uncertainty (dB)
Test Frequency: 15 MHz (Models with Option 4 Only)			
10 Hz ⁽¹⁾		-77	2.5
100 Hz		-99	2.5
1 kHz		-110	2.5
10 kHz		-110	2.5
100 kHz		-122	2.5
1 MHz		-142	2.5
Test Frequency: 60 MHz (Models with Option 4 Only)			
10 Hz ⁽¹⁾		-77	2.5
100 Hz		-99	2.5
1 kHz		-110	2.5
10 kHz		-110	2.5
100 kHz		-122	2.5
1 MHz		-142	2.5
Test Frequency: 499 MHz (Models with Option 4 Only)			
10 Hz ⁽¹⁾		-77	2.5
100 Hz		-99	2.5
1 kHz		-110	2.5
10 kHz		-110	2.5
100 kHz		-122	2.5
1 MHz		-142	2.5
Test Frequencies: 600 MHz (Models with Option 5 Only)			
10 Hz ⁽¹⁾		-64	2.5
100 Hz		-83	2.5
1 kHz		-93	2.5
10 kHz		-93	2.5
100 kHz		-100	2.5
1 MHz		-111	2.5

Test Records

MG369__B	Firmware Revision:	Operator:
Serial Number:	Date:	Options:

Section 3-8 Single Sideband Phase Noise Test with AeroFlex PN9000 Phase Noise System

All MG369xB Models with Option 30 (Sheet 2 of 3)

Frequency Offset	Measured Value (dBc)	Upper Limit (dBc)	Measurement Uncertainty (dB)
Test Frequencies: 1.99 GHz (Models with Option 5 Only)			
10 Hz ⁽¹⁾		-64	2.5
100 Hz		-83	2.5
1 kHz		-93	2.5
10 kHz		-93	2.5
100 kHz		-100	2.5
1 MHz		-111	2.5
Test Frequency: 2.01 GHz (Models without Option 4 Only)			
10 Hz ⁽¹⁾		-54	2.5
100 Hz		-77	2.5
1 kHz		-93	2.5
10 kHz		-93	2.5
100 kHz		-102	2.5
1 MHz		-130	2.5
Test Frequency: 2.19 GHz (Models with Option 4 Only)			
10 Hz ⁽¹⁾		-64	2.5
100 Hz		-86	2.5
1 kHz		-98	2.5
10 kHz		-98	2.5
100 kHz		-110	2.5
1 MHz		-135	2.5
Test Frequency: 6.0 GHz			
10 Hz ⁽¹⁾		-52	2.5
100 Hz		-73	2.5
1 kHz		-93	2.5
10 kHz		-93	2.5
100 kHz		-105	2.5
1 MHz		-128	2.5

MG369__B	Firmware Revision:	Operator:
Serial Number:	Date:	Options:

Section 3-8 Single Sideband Phase Noise Test with AeroFlex PN9000 Phase Noise System

All MG369xB Models with Option 30 (Sheet 3 of 3)

Frequency Offset	Measured Value (dBc)	Upper Limit (dBc)	Measurement Uncertainty (dB)
Test Frequency: 10.0 GHz (8 GHz for MG3691B)			
10 Hz ⁽¹⁾		-52	2.5
100 Hz		-73	2.5
1 kHz		-93	2.5
10 kHz		-93	2.5
100 kHz		-105	2.5
1 MHz		-128	2.5
Test Frequency: 19.99 GHz (not performed on MG3691B)			
10 Hz ⁽¹⁾		-45	2.5
100 Hz		-68	2.5
1 kHz		-86	2.5
10 kHz		-86	2.5
100 kHz		-100	2.5
1 MHz		-125	2.5
Test Frequency: 20.01 GHz (not performed on MG3691B or MG3692B)			
10 Hz ⁽¹⁾		-45	2.5
100 Hz		-63	2.5
1 kHz		-80	2.5
10 kHz		-80	2.5
100 kHz		-94	2.5
1 MHz		-119	2.5
Test Frequency: 25.0 GHz (not performed on MG3691B or MG3692B)			
10 Hz ⁽¹⁾		-45	2.5
100 Hz		-63	2.5
1 kHz		-80	2.5
10 kHz		-80	2.5
100 kHz		-94	2.5
1 MHz		-119	2.5

1. On some AeroFlex Test Stations 10 Hz is not reported so use 10.23 Hz.

Test Records

MG369__B	Firmware Revision:	Operator:
Serial Number:	Date:	Options:

Section 3-8 Single Sideband Phase Noise Test: Power Line and Fan Rotation Emissions with AeroFlex PN9000 Phase Noise System

All MG369xB Models (Sheet 1 of 3)

Frequency Offset	Measured Value (dBc)	Upper Limit (dBc)	Measurement Uncertainty (dB)
Test Frequency: 15 MHz (Models with Option 4 Only)			
< 300 Hz		-68	2.5
300 Hz to 1 kHz		-72	2.5
> 1 kHz		-72	2.5
Test Frequency: 30 MHz (Models with Options 4 and 3 Only)			
< 300 Hz		-68	2.5
300 Hz to 1 kHz		-72	2.5
> 1 kHz		-72	2.5
Test Frequency: 60 MHz (Models with Option 4 Only)			
< 300 Hz		-68	2.5
300 Hz to 1 kHz		-72	2.5
> 1 kHz		-72	2.5
Test Frequency: 120 MHz (Models with Options 4 and 3 Only)			
< 300 Hz		-68	2.5
300 Hz to 1 kHz		-72	2.5
> 1 kHz		-72	2.5
Test Frequency: 250 MHz (Models with Options 4 and 3 Only)			
< 300 Hz		-68	2.5
300 Hz to 1 kHz		-72	2.5
> 1 kHz		-72	2.5
Test Frequency: 499 MHz (Models with Option 4 Only)			
< 300 Hz		-68	2.5
300 Hz to 1 kHz		-72	2.5
> 1 kHz		-72	2.5
Test Frequencies: 600 MHz (Models with Option 5 Only)			
< 300 Hz		-50	2.5
300 Hz to 1 kHz		-60	2.5
> 1 kHz		-60	2.5

MG369__B	Firmware Revision:	Operator:
Serial Number:	Date:	Options:

Section 3-8 Single Sideband Phase Noise Test: Power Line and Fan Rotation Emissions with AeroFlex PN9000 Phase Noise System

All MG369xB Models (Sheet 2 of 3)

Frequency Offset	Measured Value (dBc)	Upper Limit (dBc)	Measurement Uncertainty (dB)
Test Frequencies: 1.99 GHz (Models with Option 5 Only)			
< 300 Hz		-50	2.5
300 Hz to 1 kHz		-60	2.5
> 1 kHz		-60	2.5
Test Frequency: 2.01 GHz (Models without Option 4 Only)			
< 300 Hz		-50	2.5
300 Hz to 1 kHz		-60	2.5
> 1 kHz		-60	2.5
Test Frequency: 2.19 GHz (Models with Option 4 Only)			
< 300 Hz		-56	2.5
300 Hz to 1 kHz		-66	2.5
> 1 kHz		-66	2.5
Test Frequency: 6.0 GHz			
< 300 Hz		-50	2.5
300 Hz to 1 kHz		-60	2.5
> 1 kHz		-60	2.5
Test Frequency: 10.0 GHz (8 GHz for MG3691B)			
< 300 Hz		-46	2.5
300 Hz to 1 kHz		-56	2.5
> 1 kHz		-60	2.5
Test Frequency: 19.99 GHz (not performed on MG3691B)			
< 300 Hz		-46	2.5
300 Hz to 1 kHz		-56	2.5
> 1 kHz		-60	2.5
Test Frequency: 20.01 GHz (not performed on MG3691B or MG3692B)			
< 300 Hz		-40	2.5
300 Hz to 1 kHz		-50	2.5
> 1 kHz		-54	2.5

Test Records

MG369__B	Firmware Revision:	Operator:
Serial Number:	Date:	Options:

Section 3-8 Single Sideband Phase Noise Test: Power Line and Fan Rotation Emissions with AeroFlex PN9000 Phase Noise System

All MG369xB Models (Sheet 3 of 3)

Frequency Offset	Measured Value (dBc)	Upper Limit (dBc)	Measurement Uncertainty (dB)
Test Frequency: 25.0 GHz (not performed on MG3691B or MG3692B)			
< 300 Hz		-40	2.5
300 Hz to 1 kHz		-50	2.5
> 1 kHz		-54	2.5

MG369__B	Firmware Revision:	Operator:
Serial Number:	Date:	Options:

Section 3-9 Power Level Log Conformity Test

All MG369xB Models (Sheet 1 of 2)

Set L1 ⁽¹⁾ to:	Set F1 to 2.199 GHz (Option 4) or 1.999 GHz (Option 5) Only		Set F1 to 2.201 GHz (Option 4) or 2.001 GHz (All Others)		Specification (dBm)	Measurement Uncertainty (dB)
	Measured Power Non-pulse Mode (dBm)	Measured Power Pulse Mode (dBm)	Measured Power Non-pulse Mode (dBm)	Measured Power Pulse Mode (dBm)		
+25 dBm ⁽²⁾					+24 to +26	0.44
+24 dBm ⁽²⁾					+23 to +25	0.44
+23 dBm ⁽²⁾					+22 to +24	0.44
+22 dBm ⁽²⁾					+21 to +23	0.44
+21 dBm ⁽²⁾					+20 to +22	0.44
+20 dBm ⁽²⁾					+19 to +21	0.44
+19 dBm					+18 to +20	0.44
+18 dBm					+17 to +19	0.44
+17 dBm					+16 to +18	0.44
+16 dBm					+15 to +17	0.44
+15 dBm					+14 to +16	0.44
+14 dBm					+13 to +15	0.44
+13 dBm					+12 to +14	0.44
+12 dBm					+11 to +13	0.44
+11 dBm					+10 to +12	0.44
+10 dBm					+9 to +11	0.44
+9 dBm					+8 to +10	0.44
+8 dBm					+7 to +9	0.44
+7 dBm					+6 to +8	0.44
+6 dBm					+5 to +7	0.44
+5 dBm					+4 to +6	0.44
+4 dBm					+3 to +5	0.44
+3 dBm					+2 to +4	0.44
+2 dBm					+1 to +3	0.44
+1 dBm					+0 to +2	0.44
+0 dBm					-1 to +1	0.44
-1 dBm					-2 to +0	0.44
-2 dBm					-3 to -1	0.44
-3 dBm					-4 to -2	0.44

Test Records

MG369__B	Firmware Revision:	Operator:
Serial Number:	Date:	Options:

Section 3-9 Power Level Log Conformity Test

All MG369xB Models (Sheet 2 of 2)

Set L1 ⁽¹⁾ to:	Set F1 to 2.199 GHz (Option 4) or 1.999 GHz (Option 5) Only		Set F1 to 2.201 GHz (Option 4) or 2.001 GHz (All Others)		Specification (dBm)	Measurement Uncertainty (dB)
	Measured Power Non-pulse Mode (dBm)	Measured Power Pulse Mode (dBm)	Measured Power Non-pulse Mode (dBm)	Measured Power Pulse Mode (dBm)		
-4 dBm					-5 to -3	0.44
-5 dBm					-6 to -4	0.44

1. Start with the highest power level within instrument specification.
2. Attenuator is required.

MG369__B	Firmware Revision:	Operator:
Serial Number:	Date:	Options:

Section 3-9 Power Level Accuracy Test

All MG369xB Models without Option 2 (Sheet 1 of 3)

Set L1 ⁽¹⁾ to:	Measured Power (dBm)	Measured Power (dBm)	Measured Power (dBm)	Specification ⁽²⁾ (dBm)	Measurement Uncertainty (dB)
DUT F1: 10 MHz		DUT F1: 15 MHz			
+25 dBm ⁽³⁾	N/A	N/A	N/A	+23.5 to +26.5	0.44
+20 dBm ⁽³⁾	N/A	N/A	N/A	+18.5 to +21.5	0.44
+15 dBm			N/A	+13.5 to +16.5	0.44
+10 dBm			N/A	+8.5 to +11.5	0.44
+5 dBm			N/A	+3.5 to +6.5	0.44
+0 dBm			N/A	-1.5 to +1.5	0.44
-5 dBm			N/A	-6.5 to -3.5	0.44
DUT F1: 60 MHz		DUT F1: 500 MHz		DUT F1: 600 MHz	
+25 dBm ⁽³⁾				+24 to +26	0.44
+20 dBm ⁽³⁾				+19 to +21	0.44
+15 dBm				+14 to +16	0.44
+10 dBm				+9 to +11	0.44
+5 dBm				+4 to +6	0.44
+0 dBm				-1 to +1	0.44
-5 dBm				-6 to -4	0.44
DUT F1: 2.0 GHz		DUT F1: 4.0 GHz		DUT F1: 6.0 GHz	
+25 dBm ⁽³⁾				+24 to +26	0.44
+20 dBm ⁽³⁾				+19 to +21	0.44
+15 dBm				+14 to +16	0.44
+10 dBm				+9 to +11	0.44
+5 dBm				+4 to +6	0.44
+0 dBm				-1 to +1	0.44
-5 dBm				-6 to -4	0.44
DUT F1: 8.0 GHz		DUT F1: 10.0 GHz		DUT F1: 12.0 GHz	
+25 dBm ⁽³⁾				+24 to +26	0.44
+20 dBm ⁽³⁾				+19 to +21	0.44
+15 dBm				+14 to +16	0.44
+10 dBm				+9 to +11	0.44
+5 dBm				+4 to +6	0.44
+0 dBm				-1 to +1	0.44
-5 dBm				-6 to -4	0.44

Test Records

MG369__B	Firmware Revision:	Operator:
Serial Number:	Date:	Options:

Section 3-9 Power Level Accuracy Test

All MG369xB Models without Option 2 (Sheet 2 of 3)

Set L1 ⁽¹⁾ to:	Measured Power (dBm)	Measured Power (dBm)	Measured Power (dBm)	Specification ⁽²⁾ (dBm)	Measurement Uncertainty (dB)
DUT F1: 14.0 GHz DUT F1: 16.0 GHz DUT F1: 18.0 GHz					
+25 dBm ⁽³⁾				+24 to +26	0.44
+20 dBm ⁽³⁾				+19 to +21	0.44
+15 dBm				+14 to +16	0.44
+10 dBm				+9 to +11	0.44
+5 dBm				+4 to +6	0.44
+0 dBm				-1 to +1	0.44
-5 dBm				-6 to -4	0.44
DUT F1: 20.0 GHz DUT F1: 22.0 GHz DUT F1: 24.0 GHz					
+25 dBm ⁽³⁾				+24 to +26	0.44
+20 dBm ⁽³⁾				+19 to +21	0.44
+15 dBm				+14 to +16	0.44
+10 dBm				+9 to +11	0.44
+5 dBm				+4 to +6	0.44
+0 dBm				-1 to +1	0.44
-5 dBm				-6 to -4	0.44
DUT F1: 26.0 GHz DUT F1: 28.0 GHz DUT F1: 30.0 GHz					
+25 dBm ⁽³⁾				+24 to +26	0.44
+20 dBm ⁽³⁾				+19 to +21	0.44
+15 dBm				+14 to +16	0.44
+10 dBm				+9 to +11	0.44
+5 dBm				+4 to +6	0.44
+0 dBm				-1 to +1	0.44
-5 dBm				-6 to -4	0.44
DUT F1: 32.0 GHz DUT F1: 34.0 GHz DUT F1: 36.0 GHz					
+25 dBm ⁽³⁾				+24 to +26	0.44
+20 dBm ⁽³⁾				+19 to +21	0.44
+15 dBm				+14 to +16	0.44
+10 dBm				+9 to +11	0.44
+5 dBm				+4 to +6	0.44
+0 dBm				-1 to +1	0.44
-5 dBm				-6 to -4	0.44

MG369__B	Firmware Revision:	Operator:
Serial Number:	Date:	Options:

Section 3-9 Power Level Accuracy Test

All MG369xB Models without Option 2 (Sheet 3 of 3)

Set L1 ⁽¹⁾ to:	Measured Power (dBm)	Measured Power (dBm)	Measured Power (dBm)	Specification ⁽²⁾ (dBm)	Measurement Uncertainty (dB)
DUT F1: 38.0 GHz DUT F1: 40.0 GHz					
+25 dBm ⁽³⁾			N/A	+24 to +26	0.44
+20 dBm ⁽³⁾			N/A	+19 to +21	0.44
+15 dBm			N/A	+14 to +16	0.44
+10 dBm			N/A	+9 to +11	0.44
+5 dBm			N/A	+4 to +6	0.44
+0 dBm			N/A	-1 to +1	0.44
-5 dBm			N/A	-6 to -4	0.44
DUT F1: 50.0 GHz DUT F1: 60.0 GHz DUT F1: 65 or 67.0 GHz⁽⁴⁾					
+10 dBm		N/A	N/A	+13.5 to +16.5	0.44
+5 dBm				+8.5 to +11.5	0.44
+0 dBm				+3.5 to +6.5	0.44
-5 dBm				-1.5 to +1.5	0.44
-10 dBm				-6.5 to -3.5	0.44

1. Start with the highest power level within instrument specification.
2. Accuracy with high power Option ±15X is 1.5 dBm
3. Attenuator is required to prevent damaging power sensor.
4. Depending on maximum frequency of the MG369xB. Use 65 GHz or 67 GHz.

Test Records

MG369__B	Firmware Revision:	Operator:
Serial Number:	Date:	Options:

Section 3-9 Power Level Accuracy Test

All MG369xB Models with Option 2 (Sheet 1 of 11)

Set L1 ⁽¹⁾ to:	Measured Power (dBm)	Measured Power (dBm)	Measured Power (dBm)	Specification ⁽²⁾ (dBm)	Measurement Uncertainty (dB)
	DUT F1: 10 MHz Receiver: 10 MHz LO: N/A	DUT F1: 15 MHz Receiver: 15 MHz LO: N/A			
+25 dBm ⁽³⁾	N/A	N/A		+23.5 to +26.5	0.44
+20 dBm ⁽³⁾	N/A	N/A		+18.5 to +21.5	0.44
+15 dBm				+13.5 to +16.5	0.44
+10 dBm				+8.5 to +11.5	0.44
+5 dBm				+3.5 to +6.5	0.44
+0 dBm				-1.5 to +1.5	0.44
-5 dBm				-6.5 to -3.5	0.44
-10 dBm				-11.5 to -8.5	0.44
-15 dBm				-16.5 to -13.5	0.44
-20 dBm				-21.5 to -18.5	0.44
-25 dBm				-26.5 to -23.5	0.44
-30 dBm				-31.5 to -28.5	0.44
-35 dBm				-36.5 to -33.5	0.44
-40 dBm				-41.5 to -38.5	0.44
-45 dBm				-46.5 to -43.5	0.44
-50 dBm				-51.5 to -48.5	0.44
-55 dBm				-56.5 to -53.5	0.20
-60 dBm				-61.5 to -58.5	0.20
-65 dBm				-66.5 to -63.5	0.20
-70 dBm				-71.5 to -68.5	0.20
-75 dBm				-76.5 to -73.5	0.20
-80 dBm				-81.5 to -78.5	0.20
-85 dBm				-86.5 to -83.5	0.20
-90 dBm				-91.5 to -88.5	0.20
-95 dBm				-96.5 to -93.5	0.20

MG369__B	Firmware Revision:	Operator:
Serial Number:	Date:	Options:

Section 3-9 Power Level Accuracy Test

All MG369xB Models with Option 2 (Sheet 2 of 11)

Set L1 ⁽¹⁾ to:	Measured Power (dBm)	Measured Power (dBm)	Measured Power (dBm)	Specification ⁽²⁾ (dBm)	Measurement Uncertainty (dB)
	DUT F1: 60 MHz Receiver: 60 MHz LO: N/A	DUT F1: 500 MHz Receiver: 500 MHz LO: N/A	DUT F1: 600 MHz Receiver: 600 MHz LO: N/A		
+25 dBm ⁽³⁾				+24 to +26	0.44
+20 dBm ⁽³⁾				+19 to +21	0.44
+15 dBm				+14 to +16	0.44
+10 dBm				+9 to +11	0.44
+5 dBm				+4 to +6	0.44
+0 dBm				-1 to +1	0.44
-5 dBm				-6 to -4	0.44
-10 dBm				-11 to -9	0.44
-15 dBm				-16 to -14	0.44
-20 dBm				-21 to -19	0.44
-25 dBm				-26 to -24	0.44
-30 dBm				-31 to -29	0.44
-35 dBm				-36 to -34	0.44
-40 dBm				-41 to -39	0.44
-45 dBm				-46 to -44	0.44
-50 dBm				-51 to -49	0.44
-55 dBm				-56 to -54	0.20
-60 dBm				-61 to -59	0.20
-65 dBm				-66 to -64	0.20
-70 dBm				-71 to -69	0.20
-75 dBm				-76 to -74	0.20
-80 dBm				-81 to -79	0.20
-85 dBm				-86 to -84	0.20
-90 dBm				-91 to -89	0.20
-95 dBm				-96 to -94	0.20

Test Records

MG369__B	Firmware Revision:	Operator:
Serial Number:	Date:	Options:

Section 3-9 Power Level Accuracy Test

All MG369xB Models with Option 2 (Sheet 3 of 11)

Set L1 ⁽¹⁾ to:	Measured Power (dBm)	Measured Power (dBm)	Measured Power (dBm)	Specification ⁽²⁾ (dBm)	Measurement Uncertainty (dB)
	DUT F1: 1.0 GHz Receiver: 1.0 GHz LO: N/A	DUT F1: 2.0 GHz Receiver: 2.0 GHz LO: N/A			
+25 dBm ⁽³⁾				+24 to +26	0.44
+20 dBm ⁽³⁾				+19 to +21	0.44
+15 dBm				+14 to +16	0.44
+10 dBm				+9 to +11	0.44
+5 dBm				+4 to +6	0.44
+0 dBm				-1 to +1	0.44
-5 dBm				-6 to -4	0.44
-10 dBm				-11 to -9	0.44
-15 dBm				-16 to -14	0.44
-20 dBm				-21 to -19	0.44
-25 dBm				-26 to -24	0.44
-30 dBm				-31 to -29	0.44
-35 dBm				-36 to -34	0.44
-40 dBm				-41 to -39	0.44
-45 dBm				-46 to -44	0.44
-50 dBm				-51 to -49	0.44
-55 dBm				-56 to -54	0.20
-60 dBm				-61 to -59	0.20
-65 dBm				-66 to -64	0.20
-70 dBm				-71 to -69	0.20
-75 dBm				-76 to -74	0.20
-80 dBm				-81 to -79	0.20
-85 dBm				-86 to -84	0.20
-90 dBm				-91 to -89	0.20
-95 dBm				-96 to -94	0.20

MG369__B	Firmware Revision:	Operator:
Serial Number:	Date:	Options:

Section 3-9 Power Level Accuracy Test

All MG369xB Models with Option 2 (Sheet 4 of 11)

Set L1 ⁽¹⁾ to:	Measured Power (dBm)	Measured Power (dBm)	Measured Power (dBm)	Specification ⁽²⁾ (dBm)	Measurement Uncertainty (dB)
DUT F1: 4.0 GHz Receiver: 8.51 MHz LO: 3991.49 MHz					
+25 dBm ⁽³⁾				+24 to +26	0.44
+20 dBm ⁽³⁾				+19 to +21	0.44
+15 dBm				+14 to +16	0.44
+10 dBm				+9 to +11	0.44
+5 dBm				+4 to +6	0.44
+0 dBm				-1 to +1	0.44
-5 dBm				-6 to -4	0.44
-10 dBm				-11 to -9	0.44
-15 dBm				-16 to -14	0.44
-20 dBm				-21 to -19	0.44
-25 dBm				-26 to -24	0.44
-30 dBm				-31 to -29	0.44
-35 dBm				-36 to -34	0.44
-40 dBm				-41 to -39	0.44
-45 dBm				-46 to -44	0.44
-50 dBm				-51 to -49	0.44
-55 dBm				-56 to -54	0.49
-60 dBm				-61 to -59	0.49
-65 dBm				-66 to -64	0.49
-70 dBm				-71 to -69	0.49
-75 dBm				-76 to -74	0.49
-80 dBm				-81 to -79	0.49
-85 dBm				-86 to -84	0.49
-90 dBm				-91 to -89	0.49
-95 dBm				-96 to -94	0.49

Test Records

MG369__B	Firmware Revision:	Operator:
Serial Number:	Date:	Options:

Section 3-9 Power Level Accuracy Test

All MG369xB Models with Option 2 (Sheet 5 of 11)

Set L1 ⁽¹⁾ to:	Measured Power (dBm)	Measured Power (dBm)	Measured Power (dBm)	Specification ⁽²⁾ (dBm)	Measurement Uncertainty (dB)
	DUT F1: 6.0 GHz Receiver: 8.51 MHz LO: 5991.49 MHz	DUT F1: 8.0 GHz Receiver: 8.51 MHz LO: 7991.49 MHz	DUT F1: 10.0 GHz Receiver: 8.51 MHz LO: 9991.49 MHz		
+25 dBm ⁽³⁾				+24 to +26	0.44
+20 dBm ⁽³⁾				+19 to +21	0.44
+15 dBm				+14 to +16	0.44
+10 dBm				+9 to +11	0.44
+5 dBm				+4 to +6	0.44
+0 dBm				-1 to +1	0.44
-5 dBm				-6 to -4	0.44
-10 dBm				-11 to -9	0.44
-15 dBm				-16 to -14	0.44
-20 dBm				-21 to -19	0.44
-25 dBm				-26 to -24	0.44
-30 dBm				-31 to -29	0.44
-35 dBm				-36 to -34	0.44
-40 dBm				-41 to -39	0.44
-45 dBm				-46 to -44	0.44
-50 dBm				-51 to -49	0.44
-55 dBm				-56 to -54	0.49
-60 dBm				-61 to -59	0.49
-65 dBm				-66 to -64	0.49
-70 dBm				-71 to -69	0.49
-75 dBm				-76 to -74	0.49
-80 dBm				-81 to -79	0.49
-85 dBm				-86 to -84	0.49
-90 dBm				-91 to -89	0.49
-95 dBm				-96 to -94	0.49

MG369__B	Firmware Revision:	Operator:
Serial Number:	Date:	Options:

Section 3-9 Power Level Accuracy Test

All MG369xB Models with Option 2 (Sheet 6 of 11)

Set L1 ⁽¹⁾ to:	Measured Power (dBm)	Measured Power (dBm)	Measured Power (dBm)	Specification ⁽²⁾ (dBm)	Measurement Uncertainty (dB)
	DUT F1: 12.0 GHz Receiver: 8.51 MHz LO: 11991.49 MHz	DUT F1: 14.0 GHz Receiver: 8.51 MHz LO: 13991.49 MHz	DUT F1: 16.0 GHz Receiver: 8.51 MHz LO: 15991.49 MHz		
+25 dBm ⁽³⁾				+24 to +26	0.44
+20 dBm ⁽³⁾				+19 to +21	0.44
+15 dBm				+14 to +16	0.44
+10 dBm				+9 to +11	0.44
+5 dBm				+4 to +6	0.44
+0 dBm				-1 to +1	0.44
-5 dBm				-6 to -4	0.44
-10 dBm				-11 to -9	0.44
-15 dBm				-16 to -14	0.44
-20 dBm				-21 to -19	0.44
-25 dBm				-26 to -24	0.44
-30 dBm				-31 to -29	0.44
-35 dBm				-36 to -34	0.44
-40 dBm				-41 to -39	0.44
-45 dBm				-46 to -44	0.44
-50 dBm				-51 to -49	0.44
-55 dBm				-56 to -54	0.49
-60 dBm				-61 to -59	0.49
-65 dBm				-66 to -64	0.49
-70 dBm				-71 to -69	0.49
-75 dBm				-76 to -74	0.49
-80 dBm				-81 to -79	0.49
-85 dBm				-86 to -84	0.49
-90 dBm				-91 to -89	0.49
-95 dBm				-96 to -94	0.49

Test Records

MG369__B	Firmware Revision:	Operator:
Serial Number:	Date:	Options:

Section 3-9 Power Level Accuracy Test

All MG369xB Models with Option 2 (Sheet 7 of 11)

Set L1 ⁽¹⁾ to:	Measured Power (dBm)	Measured Power (dBm)	Measured Power (dBm)	Specification ⁽²⁾ (dBm)	Measurement Uncertainty (dB)
	DUT F1: 18.0 GHz Receiver: 8.51 MHz LO: 17991.49 MHz	DUT F1: 20.0 GHz Receiver: 8.51 MHz LO: 19991.49 MHz	DUT F1: 22.0 GHz Receiver: 8.51 MHz LO: 21991.49 MHz		
+25 dBm ⁽³⁾				+24 to +26	0.44
+20 dBm ⁽³⁾				+19 to +21	0.44
+15 dBm				+14 to +16	0.44
+10 dBm				+9 to +11	0.44
+5 dBm				+4 to +6	0.44
+0 dBm				-1 to +1	0.44
-5 dBm				-6 to -4	0.44
-10 dBm				-11 to -9	0.44
-15 dBm				-16 to -14	0.44
-20 dBm				-21 to -19	0.44
-25 dBm				-26 to -24	0.44
-30 dBm				-31 to -29	0.44
-35 dBm				-36 to -34	0.44
-40 dBm				-41 to -39	0.44
-45 dBm				-46 to -44	0.44
-50 dBm				-51 to -49	0.44
-55 dBm				-56 to -54	0.49
-60 dBm				-61 to -59	0.49
-65 dBm				-66 to -64	0.49
-70 dBm				-71 to -69	0.49
-75 dBm				-76 to -74	0.49
-80 dBm				-81 to -79	0.49
-85 dBm				-86 to -84	0.49
-90 dBm				-91 to -89	0.49
-95 dBm				-96 to -94	0.49

MG369__B	Firmware Revision:	Operator:
Serial Number:	Date:	Options:

Section 3-9 Power Level Accuracy Test

All MG369xB Models with Option 2 (Sheet 8 of 11)

Set L1 ⁽¹⁾ to:	Measured Power (dBm)	Measured Power (dBm)	Measured Power (dBm)	Specification ⁽²⁾ (dBm)	Measurement Uncertainty (dB)
	DUT F1: 24.0 GHz Receiver: 8.51 MHz LO: 23991.49 MHz	DUT F1: 26.0 GHz Receiver: 8.51 MHz LO: 25991.49 MHz	DUT F1: 28.0 GHz Receiver: 8.51 MHz LO: 27991.49 MHz		
+25 dBm ⁽³⁾				+24 to +26	0.44
+20 dBm ⁽³⁾				+19 to +21	0.44
+15 dBm				+14 to +16	0.44
+10 dBm				+9 to +11	0.44
+5 dBm				+4 to +6	0.44
+0 dBm				-1 to +1	0.44
-5 dBm				-6 to -4	0.44
-10 dBm				-11 to -9	0.44
-15 dBm				-16 to -14	0.44
-20 dBm				-21 to -19	0.44
-25 dBm				-26 to -24	0.44
-30 dBm				-31 to -29	0.44
-35 dBm				-36 to -34	0.44
-40 dBm				-41 to -39	0.44
-45 dBm				-46 to -44	0.44
-50 dBm				-51 to -49	0.44
-55 dBm				-56 to -54	0.49
-60 dBm				-61 to -59	0.49
-65 dBm				-66 to -64	0.49
-70 dBm				-71 to -69	0.49
-75 dBm				-76 to -74	0.49
-80 dBm				-81 to -79	0.49
-85 dBm				-86 to -84	0.49
-90 dBm				-91 to -89	0.49
-95 dBm				-96 to -94	0.49

Test Records

MG369__B	Firmware Revision:	Operator:
Serial Number:	Date:	Options:

Section 3-9 Power Level Accuracy Test

All MG369xB Models with Option 2 (Sheet 9 of 11)

Set L1 ⁽¹⁾ to:	Measured Power (dBm)	Measured Power (dBm)	Measured Power (dBm)	Specification ⁽²⁾ (dBm)	Measurement Uncertainty (dB)
	DUT F1: 30.0 GHz Receiver: 8.51 MHz LO: 29991.49 MHz	DUT F1: 32.0 GHz Receiver: 8.51 MHz LO: 31991.49 MHz	DUT F1: 34.0 GHz Receiver: 8.51 MHz LO: 33991.49 MHz		
+25 dBm ⁽³⁾				+24 to +26	0.44
+20 dBm ⁽³⁾				+19 to +21	0.44
+15 dBm				+14 to +16	0.44
+10 dBm				+9 to +11	0.44
+5 dBm				+4 to +6	0.44
+0 dBm				-1 to +1	0.44
-5 dBm				-6 to -4	0.44
-10 dBm				-11 to -9	0.44
-15 dBm				-16 to -14	0.44
-20 dBm				-21 to -19	0.44
-25 dBm				-26 to -24	0.44
-30 dBm				-31 to -29	0.44
-35 dBm				-36 to -34	0.44
-40 dBm				-41 to -39	0.44
-45 dBm				-46 to -44	0.44
-50 dBm				-51 to -49	0.44
-55 dBm				-56 to -54	0.49
-60 dBm				-61 to -59	0.49
-65 dBm				-66 to -64	0.49
-70 dBm				-71 to -69	0.49
-75 dBm				-76 to -74	0.49
-80 dBm				-81 to -79	0.49
-85 dBm				-86 to -84	0.49
-90 dBm				-91 to -89	0.49
-95 dBm				-96 to -94	0.49

MG369__B	Firmware Revision:	Operator:
Serial Number:	Date:	Options:

Section 3-9 Power Level Accuracy Test

All MG369xB Models with Option 2 (Sheet 10 of 11)

Set L1 ⁽¹⁾ to:	Measured Power (dBm)	Measured Power (dBm)	Measured Power (dBm)	Specification ⁽²⁾ (dBm)	Measurement Uncertainty (dB)
	DUT F1: 36.0 GHz Receiver: 8.51 MHz LO: 35991.49 MHz	DUT F1: 38.0 GHz Receiver: 8.51 MHz LO: 37991.49 MHz	DUT F1: 40.0 GHz Receiver: 8.51 MHz LO: 39991.49 MHz		
+25 dBm ⁽³⁾				+24 to +26	0.44
+20 dBm ⁽³⁾				+19 to +21	0.44
+15 dBm				+14 to +16	0.44
+10 dBm				+9 to +11	0.44
+5 dBm				+4 to +6	0.44
+0 dBm				-1 to +1	0.44
-5 dBm				-6 to -4	0.44
-10 dBm				-11 to -9	0.44
-15 dBm				-16 to -14	0.44
-20 dBm				-21 to -19	0.44
-25 dBm				-26 to -24	0.44
-30 dBm				-31 to -29	0.44
-35 dBm				-36 to -34	0.44
-40 dBm				-41 to -39	0.44
-45 dBm				-46 to -44	0.44
-50 dBm				-51 to -49	0.44
-55 dBm				-56 to -54	0.49
-60 dBm				-61 to -59	0.49
-65 dBm				-66 to -64	0.49
-70 dBm				-71 to -69	0.49
-75 dBm				-76 to -74	0.49
-80 dBm				-81 to -79	0.49
-85 dBm				-86 to -84	0.49
-90 dBm				-91 to -89	0.49
-95 dBm				-96 to -94	0.49

Test Records

MG369__B	Firmware Revision:	Operator:
Serial Number:	Date:	Options:

Section 3-9 Power Level Accuracy Test

All MG369xB Models with Option 2 (Sheet 11 of 11)

Set L1 ⁽¹⁾ to:	Measured Power (dBm)	Measured Power (dBm)	Measured Power (dBm)	Specification ⁽²⁾ (dBm)	Measurement Uncertainty (dB)
	DUT F1: 50.0 GHz ⁽⁵⁾ Receiver: N/A LO: N/A	DUT F1: 60.0 Hz ⁽⁵⁾ Receiver: N/A LO: N/A	DUT F1: 65 or 67.0 GHz ⁽⁴⁾⁽⁵⁾ Receiver: N/A LO: N/A		
+10 dBm		N/A	N/A	+8.5 to +11.5	0.44
+5 dBm				+3.5 to +6.5	0.44
+0 dBm				-1.5 to +1.5	0.44
-5 dBm				-6.5 to -3.5	0.44
-10 dBm				-11.5 to -8.5	0.44
-15 dBm				-16.5 to -13.5	0.44
-20 dBm				-21.5 to -18.5	0.44
-25 dBm				-26.5 to -23.5	0.44
-30 dBm		N/A	N/A	-31.5 to -28.5	0.44
-35 dBm		N/A	N/A	-36.5 to -33.5	0.44
-40 dBm		N/A	N/A	-41.5 to -38.5	0.44
-45 dBm		N/A	N/A	-46.5 to -43.5	0.44
-50 dBm		N/A	N/A	-51.5 to -48.5	0.44
-55 dBm		N/A	N/A	-56.5 to -53.5	0.44
-60 dBm		N/A	N/A	-61.5 to -58.5	0.44

1. Start with the highest power level within instrument specification.
2. Accuracy with high power Option 15X is ± 1.5 dBm.
3. Attenuator is required to prevent damaging power sensor.
4. Depending on maximum frequency of the MG369xB. Use 65 GHz or 67 GHz.
5. These measurement use the power meter and power sensor only.

MG369__B	Firmware Revision:	Operator:
Serial Number:	Date:	Options:

Section 3-9 Power Level Flatness Test

All MG369xB Models without Option 2 (1 of 2)

MG3691B and MG3692B

Set L1 to +17 dBm (for models with Option 22, set L1 to +15 dBm)

Frequency Range	Power Sensor	# of steps	Maximum Power (dBm)	Minimum Power (dBm)	Variation (Max – Min) (dB)	Variation Spec. (dB)	Measurement Uncertainty (dB)
Minimum Frequency ⁽¹⁾ to < 20 MHz (no Opt. 15x) ⁽²⁾	SC7400	5				3.00	0.289
20 MHz to 50 MHz (no Option 15x) ⁽²⁾	SC7400	5				1.60	0.281
50 MHz ⁽³⁾ to Maximum Frequency (no Option 15x)	MA2474D	190				1.60	0.539
Minimum Frequency ⁽¹⁾ to 50 MHz (with Opt. 15x) ⁽²⁾	SC7400	10				3.00	0.281
50 MHz ⁽³⁾ to Maximum Frequency (with Opt. 15x)	MA2474D	190				3.00	0.539

MG3693B and MG3694B

Set L1 to +6 dBm (for models with Option 22, set L1 to +4 dBm)

Frequency Range	Power Sensor	# of Steps	Maximum Power (dBm)	Minimum Power (dBm)	Variation (Max – Min) (dB)	Variation Spec. (dB)	Measurement Uncertainty (dB)
Minimum frequency ⁽¹⁾ to < 20 MHz (no Opt. 15x) ⁽²⁾	SC7400	5				3.00	0.289
20 MHz to 50 MHz (no Option 15x) ⁽²⁾	SC7400	5				1.60	0.281
50 MHz ⁽³⁾ to Maximum Frequency (no Option 15x)	MA2474D	190				1.60	0.736
Minimum Frequency ⁽¹⁾ to 50 MHz (with Opt. 15x) ⁽²⁾	SC7400	10				3.00	0.281
50 MHz ⁽³⁾ to Maximum Frequency (with Opt. 15x)	MA2474D	190				3.00	0.736

1. 100K if Option 22 installed or 10 MHz if Options 4 or 5 installed.
2. Perform test only if Option 4 or 5 installed.
3. 50 MHz if Option 4 or 5 installed otherwise 2 GHz.

Test Records

MG369__B	Firmware Revision:	Operator:
Serial Number:	Date:	Options:

Section 3-9 Power Level Flatness Test

All MG369xB Models without Option 2 (2 of 2)

MG3695B

Set L1 to +3 dBm (for models with Option 22, set L1 to +1 dBm)

Frequency Range	Power Sensor	# of Steps	Maximum Power (dBm)	Minimum Power (dBm)	Variation (Max – Min) (dB)	Variation Spec. (dB)	Measurement Uncertainty (dB)
Minimum frequency ⁽¹⁾ to < 20 MHz (no Opt. 15x) ⁽²⁾	SC7400	5				3.00	0.289
20 MHz to 50 MHz (no Option 15x) ⁽²⁾	SC7400	5				1.60	0.281
50 MHz ⁽³⁾ to ≤ 40 GHz (no Option 15x)	SC7430 or SC7570	40				1.60	0.584
40 GHz to 50 GHz (no Option 15x)	SC7430 or SC7570	50				2.20	0.788
Minimum Frequency ⁽¹⁾ to 50 MHz (with Opt. 15x) ⁽²⁾	SC7400	10				3.00	0.281
50 MHz ⁽³⁾ to Maximum Frequency (with Opt. 15x)	SC7430 or SC7570	190				3.00	0.788

MG3696B

Set L1 to +3 dBm (for models with Option 22, set L1 to +1 dBm)

Frequency Range	Power Sensor	# of Steps	Maximum Power (dBm)	Minimum Power (dBm)	Variation (Max – Min) (dB)	Variation Spec. (dB)	Measurement Uncertainty (dB)
Minimum frequency ⁽¹⁾ to < 20 MHz (no Opt. 15x) ⁽²⁾	SC7400	5				3.00	0.289
20 MHz to 50 MHz (no Option 15x) ⁽²⁾	SC7400	5				1.60	0.281
50 MHz ⁽³⁾ to ≤ 40 GHz (no Option 15x)	SC7430 or SC7570	40				1.60	0.584
40 GHz to Maximum Frequency (no Option 15x)	SC7430 or SC7570	50				2.20	1.716
Minimum Frequency ⁽¹⁾ to 50 MHz (with Option 15x)	SC7400	10				3.00	0.281
50 MHz ⁽³⁾ to Maximum Frequency (with Opt. 15x)	SC7430 or SC7570	190				3.00	1.716

1. 100K if Option 22 installed or 10 MHz if Options 4 or 5 installed.
2. Perform test only if Option 4 or 5 installed.
3. 50 MHz if Option 4 or 5 installed otherwise 2 GHz.

MG369__B	Firmware Revision:	Operator:
Serial Number:	Date:	Options:

Section 3-9 Power Level Flatness Test

All MG369xB Models with Option 2 (1 of 2)

MG3691B and MG3692B

Set L1 to +15 dBm (for models with Option 2E or 22, set L1 to +13 dBm; for models with Option 2E and 22, set L1 to +11 dBm.)

Frequency Range	Power Sensor	# of Steps	Maximum Power (dBm)	Minimum Power (dBm)	Variation (Max – Min) (dB)	Variation Spec. (dB)	Measurement Uncertainty (dB)
Minimum Frequency ⁽¹⁾ to < 20 MHz (no Opt. 15x) ⁽²⁾	SC7400	5				3.00	0.289
20 MHz to 50 MHz (no Option 15x) ⁽²⁾	SC7400	5				1.60	0.281
50 MHz ⁽³⁾ to Maximum Frequency (no Option 15x)	MA2474D	190				1.60	0.539
Minimum Frequency ⁽¹⁾ to 50 MHz (with Opt. 15x) ⁽²⁾	SC7400	10				3.00	0.281
50 MHz ⁽³⁾ to Maximum Frequency (with Opt. 15x)	MA2474D	190				3.00	0.539

MG3693B and MG3694B

Set L1 to +3 dBm (for models with Option 22, set L1 to +1 dBm)

Frequency Range	Power Sensor	# of Steps	Maximum Power (dBm)	Minimum Power (dBm)	Variation (Max – Min) (dB)	Variation Spec. (dB)	Measurement Uncertainty (dB)
Minimum frequency ⁽¹⁾ to < 20 MHz (no Opt. 15x) ⁽²⁾	SC7400	5				3.00	0.289
20 MHz to 50 MHz (no Option 15x) ⁽²⁾	SC7400	5				1.60	0.281
50 MHz ⁽³⁾ to Maximum Frequency (no Option 15x)	MA2474D	190				1.60	0.736
Minimum Frequency ⁽¹⁾ to 50 MHz (with Opt. 15x) ⁽²⁾	SC7400	10				3.00	0.281
50 MHz ⁽³⁾ to Maximum Frequency (with Opt. 15x)	MA2474D	190				3.00	0.736

1. 100K if Option 22 installed or 10 MHz if Options 4 or 5 installed.
2. Perform test only if Option 4 or 5 installed.
3. 50 MHz if Option 4 or 5 installed otherwise 2 GHz.

Test Records

MG369__B	Firmware Revision:	Operator:
Serial Number:	Date:	Options:

Section 3-9 Power Level Flatness Test

All MG369xB Models with Option 2 (2 of 2)

MG3695B

Set L1 to +0 dBm (for models with Option 22, set L1 to -2 dBm.)

Frequency Range	Power Sensor	# of Steps	Maximum Power (dBm)	Minimum Power (dBm)	Variation (Max – Min) (dB)	Variation Spec. (dB)	Measurement Uncertainty (dB)
Minimum frequency ⁽¹⁾ to < 20 MHz (no Opt. 15x) ⁽²⁾	SC7400	5				3.00	0.290
20 MHz to 50 MHz (no Option 15x) ⁽²⁾	SC7400	5				1.60	0.282
50 MHz ⁽³⁾ to ≤ 40 GHz (no Option 15x)	SC7430 or SC7570	40				1.60	0.584
40 GHz to 50 GHz (no Option 15x)	SC7430 or SC7570	50				2.20	0.788
Minimum Frequency ⁽¹⁾ to 50 MHz (with Opt. 15x) ⁽²⁾	SC7400	10				3.00	0.282
50 MHz ⁽³⁾ to Maximum Frequency (with Opt. 15x)	SC7430 or SC7570	190				3.00	0.788

MG3696B

Set L1 to +0 dBm (for models with Option 22, set L1 to -2 dBm.)

Frequency Range	Power Sensor	# of Steps	Maximum Power (dBm)	Minimum Power (dBm)	Variation (Max – Min) (dB)	Variation Spec. (dB)	Measurement Uncertainty (dB)
Minimum frequency ⁽¹⁾ to < 20 MHz (no Opt. 15x) ⁽²⁾	SC7400	5				3.00	0.290
20 MHz to 50 MHz (no Option 15x) ⁽²⁾	SC7400	5				1.60	0.282
50 MHz ⁽³⁾ to ≤ 40 GHz (no Option 15x)	SC7430 or SC7570	40				1.60	0.584
40 GHz to Maximum Frequency (no Option 15x)	SC7430 or SC7570	50				2.20	1.716
Minimum Frequency ⁽¹⁾ to 50 MHz (with Option 15x)	SC7400	10				3.00	0.282
50 MHz ⁽³⁾ to Maximum Frequency (with Opt. 15x)	SC7430 or SC7570	190				3.00	1.716

1. 100K if Option 22 installed or 10 MHz if Options 4 or 5 installed.
2. Perform test only if Option 4 or 5 installed.
3. 50 MHz if Option 4 or 5 installed otherwise 2 GHz.

MG369__B	Firmware Revision:	Operator:
Serial Number:	Date:	Options:

Section 3-9 Maximum Levelled Power Test

All MG369xB Models without Option 15 (1 of 2)

MG3691B

Set L1 to +20 dBm

Frequency Range (GHz)	Power Sensor	# of Steps	Minimum Measured Power (dBm)	Specification w/out Option 2 (dBm) ⁽¹⁾	Specification with Option 2 (dBm) ⁽¹⁾	Specification with Option 2E (dBm) ⁽¹⁾	Measurement Uncertainty (dB)
Minimum Frequency ⁽³⁾ to < 2.0 w/Option 5 ≤ 2.2 w/Option 4	SC7400	50		+19.0	+18.0	+15.0	0.268
≥ 2.0 to 10 w/Option 5 > 2.2 to 10 w/Option 4 to Maximum Frequency	SC7400	150		+19.0	+18.0	+13.0	0.269

MG3692B

Set L1 to +20 dBm

Frequency Range (GHz)	Power Sensor	# of Steps	Minimum Measured Power (dBm)	Specification w/out Option 2 (dBm) ⁽¹⁾	Specification with Option 2 (dBm) ⁽¹⁾	Measurement Uncertainty (dB)
Minimum Frequency ⁽³⁾ to ≤ 10.0	SC7400	100		+19.0	+18.0	0.269
> 10.0 to ≤ 20.0	MA2474D	100		+17.0	+15.0	0.539

MG3693B or MG3694B

Set L1 to +20 dBm

Frequency Range (GHz)	Power Sensor	# of Steps	Minimum Measured Power (dBm)	Specification w/out Option 2 (dBm) ⁽¹⁾	Specification with Option 2 (dBm) ⁽¹⁾	Measurement Uncertainty (dB)
Minimum Frequency ⁽³⁾ to ≤ 10.0	SC7400	50		+15.0	+14.0	0.269
> 10.0 to ≤ 20.0	MA2474D	50		+12.0	+10.0	0.539
> 20.0 to ≤ 40.0 ⁽²⁾	MA2474D	100		+6.0	+3.0	0.736

1. For models with Option 22, derate specification by 2 dB.
2. Or the maximum frequency within instrument specification.
3. 100K if Option 22 installed, 10 MHz if Options 4 or 5 is installed or 2.0 GHz if options 4, 5 or 22 are not installed.

Test Records

MG369__B	Firmware Revision:	Operator:
Serial Number:	Date:	Options:

Section 3-9 Maximum Levelled Power Test

All MG369xB Models without Option 15 (2 of 2)

MG3695B or MG3696B

Set L1 to +20 dBm

Frequency Range (GHz)	Power Sensor	# of Steps	Minimum Measured Power (dBm)	Specification w/out Option 2 (dBm) ⁽¹⁾	Specification with Option 2 (dBm) ⁽¹⁾	Measurement Uncertainty (dB)
Minimum Frequency ⁽³⁾ to < 2.0 w/Option 5 ≤ 2.2 w/Option 4	SC7400	20		+12.0	+10.0	0.268
≥ 2.0 to 10 w/Option 5 > 2.2 to 10 w/Option 4	SC7430 or SC7570	60		+10.0	+8.0	0.454
> 20.0 to ≤ Maximum Frequency ⁽⁴⁾	SC7430 or SC7570	120		+3.0	+0.0 ⁽²⁾	1.716

1. For models with Option 22, derate specification by 2 dB.

2. Typical 60-67 GHz.

3. 100K if Option 22 installed or 10 MHz if Options 4 or 5 installed.

4. 50 GHz for MG3695B, 67 (65) GHz for MG3696B without option 2 or 60 GHz for MG3696B with option 2.

MG369__B	Firmware Revision:	Operator:
Serial Number:	Date:	Options:

Section 3-9 Maximum Levelled Power Test

All MG369xB Models with Option 15 and without Options 4 or 5 (1 of 2)

MG3691B

Set L1 to +30 dBm

Frequency Range (GHz)	Power Sensor	# of Steps	Minimum Measured Power (dBm)	Specification w/out Option 2 (dBm) ⁽¹⁾	Specification with Option 2 (dBm) ⁽¹⁾	Specification with Option 2E (dBm) ⁽¹⁾	Measurement Uncertainty (dB)
Minimum Frequency ⁽³⁾ to ≤ 10.0	SC7400	200		+25.0	+23.0	+16.0	0.269

MG3692B

Set L1 to +30 dBm

Frequency Range (GHz)	Power Sensor	# of Steps	Minimum Measured Power (dBm)	Specification w/out Option 2 (dBm) ⁽¹⁾	Specification with Option 2 (dBm) ⁽¹⁾	Measurement Uncertainty (dB)
Minimum Frequency ⁽³⁾ to ≤ 10.0	SC7400	100		+23.0	+21.0	0.269
10.0 to ≤ 20.0	MA2474D	100		+23.0	+21.0	0.539

MG3693B or MG3694B

Set L1 to +30 dBm

Frequency Range (GHz)	Power Sensor	# of Steps	Minimum Measured Power (dBm)	Specification w/out Option 2 (dBm) ⁽¹⁾	Specification with Option 2 (dBm) ⁽¹⁾	Measurement Uncertainty (dB)
Minimum Frequency ⁽³⁾ to ≤ 10.0	SC7400	100		+23.0	+21.0	0.269
10.0 to ≤ 20.0	MA2474D	50		+23.0	+21.0	0.539
> 20.0 to ≤ 40.0 ⁽²⁾	MA2474D	100		+19.0	+17.0	0.736

1. For models with Option 22, derate specification by 2 dB.
2. Or the maximum frequency within instrument specification.
3. 100K if Option 22 installed, 10 MHz if Options 4 or 5 installed or 2.0 GHz if options 4, 5 or 22 are not installed.

Test Records

MG369__B	Firmware Revision:	Operator:
Serial Number:	Date:	Options:

Section 3-9 Maximum Levelled Power Test

All MG369xB Models with Option 15 and without Options 4 or 5 (2 of 2)

MG3695B

Set L1 to +30 dBm

Frequency Range (GHz)	Power Sensor	# of Steps	Minimum Measured Power (dBm)	Specification w/out Option 2 (dBm) ⁽¹⁾	Specification with Option 2 (dBm) ⁽¹⁾	Measurement Uncertainty (dB)
Minimum Frequency ⁽³⁾ to ≤ 10.0	SC7400	40		+23.0	+21.0	0.269
10.0 to ≤ 20.0	SC7430 or SC7570	40		+23.0	+21.0	0.454
> 20.0 to ≤ 40.0	SC7430 or SC7570	80		+19.0	+17.0	0.584
> 40.0 to ≤ 50.0	SC7430 or SC7570	40		+13.0	+10.0	0.790

MG3696B

Set L1 to +30 dBm

Frequency Range (GHz)	Power Sensor	# of Steps	Minimum Measured Power (dBm)	Specification w/out Option 2 (dBm) ⁽¹⁾	Specification with Option 2 (dBm) ⁽¹⁾	Measurement Uncertainty (dB)
Minimum Frequency ⁽³⁾ to ≤ 10.0	SC7400	40		+21.0	+19.0	0.269
10.0 to ≤ 20.0	SC7430 or SC7570	40		+21.0	+19.0	0.454
> 20.0 to ≤ 40.0	SC7430 or SC7570	60		+19.0	+16.0	0.584
> 40.0 to ≤ Maximum Frequency ⁽⁴⁾	SC7430 or SC7570	60		+9.0	+6.0 ⁽²⁾	1.716

1. For models with Option 22, derate specification by 2 dB.

2. Typical 60 to 67 GHz.

3. 100K if Option 22 installed, 10 MHz if Options 4 or 5 installed or 2.0 GHz if options 4, 5 or 22 are not installed.

4. 67 (65) GHz for MG3696B without option 2 or 60 GHz for MG3696B with option 2.

MG369__B	Firmware Revision:	Operator:
Serial Number:	Date:	Options:

Section 3-9 Maximum Levelled Power Test

All MG369xB Models with Option 15 and Options 4 or 5 (1 of 3)

MG3691B

Set L1 to +30 dBm

Frequency Range (GHz)	Power Sensor	# of Steps	Minimum Measured Power (dBm)	Specification w/out Option 2 (dBm) ⁽¹⁾	Specification with Option 2 (dBm) ⁽¹⁾	Specification with Option 2E (dBm) ⁽¹⁾	Measurement Uncertainty (dB)
Minimum Frequency ⁽³⁾ to < 2.0 w/Option 5 ≤ 2.2 w/Option 4	SC7400	50		+19.0	+18.0	+15.0	0.268
≥ 2.0 to 10 w/Option 5 > 2.2 to 10 w/Option 4	SC7400	150		+23.0	+21.0	+16.0	0.237

MG3692B

Set L1 to +30 dBm

Frequency Range (GHz)	Power Sensor	# of Steps	Minimum Measured Power (dBm)	Specification w/out Option 2 (dBm) ⁽¹⁾	Specification with Option 2 (dBm) ⁽¹⁾	Measurement Uncertainty (dB)
Minimum Frequency ⁽³⁾ to < 2.0 w/Option 5 ≤ 2.2 w/Option 4	SC7400	50		+19.0	+18.0	0.268
≥ 2.0 to 20 w/Option 5 > 2.2 to 20 w/Option 4	MA2474D	150		+21.0	+19.0	0.539

MG3693B

Set L1 to +30 dBm

Frequency Range (GHz)	Power Sensor	# of Steps	Minimum Measured Power (dBm)	Specification w/out Option 2 (dBm) ⁽¹⁾	Specification with Option 2 (dBm) ⁽¹⁾	Measurement Uncertainty (dB)
Minimum Frequency ⁽³⁾ to < 2.0 w/Option 5 ≤ 2.2 w/Option 4	SC7400	25		+17.0	+16.0	0.268
≥ 2.0 to 20 w/Option 5 > 2.2 to 20 w/Option 4	MA2474D	100		+21.0	+19.0	0.539
> 20 to ≤ 30.0	MA2474D	75		+17.0	+15.0	0.546

Test Records

MG369__B	Firmware Revision:	Operator:
Serial Number:	Date:	Options:

Section 3-9 Maximum Leveled Power Test

All MG369xB Models with Option 15 and Options 4 or 5 (2 of 3)

MG3694B

Set L1 to +30 dBm

Frequency Range (GHz)	Power Sensor	# of Steps	Minimum Measured Power (dBm)	Specification w/out Option 2 (dBm) ⁽¹⁾	Specification with Option 2 (dBm) ⁽¹⁾	Measurement Uncertainty (dB)
Minimum Frequency ⁽³⁾ to < 2.0 w/Option 5 ≤ 2.2 w/Option 4	SC7400	20		+17.0	+16.0	0.268
≥ 2.0 to 20 w/Option 5 > 2.2 to ≤ 20 w/Option 4	MA2474D	90		+21.0	+19.0	0.539
> 20 to ≤ 40.0	MA2474D	90		+17.0	+15.0	0.539

MG3695B

Set L1 to +30 dBm

Frequency Range (GHz)	Power Sensor	# of Steps	Minimum Measured Power (dBm)	Specification w/out Option 2 (dBm) ⁽¹⁾	Specification with Option 2 (dBm) ⁽¹⁾	Measurement Uncertainty (dB)
Minimum Frequency ⁽³⁾ to < 2.0 w/Option 5 ≤ 2.2 w/Option 4	SC7400	10		+16.0	+14.0	0.268
≥ 2.0 to 20 w/Option 5 > 2.2 to 20 w/Option 4	SC7430 or SC7570	75		+21.0	+19.0	0.454
> 20 to ≤ 40.0	SC7430 or SC7570	75		+17.0	+15.0	0.584
< 40 to ≤ 50.0	SC7430 or SC7570	40		+11.0	+8.0	0.794

MG369__B	Firmware Revision:	Operator:
Serial Number:	Date:	Options:

Section 3-9 Maximum Leveled Power Test

All MG369xB Models with Option 15 and Options 4 or 5 (3 of 3)

MG3696B

Set L1 to +30 dBm

Frequency Range (GHz)	Power Sensor	# of Steps	Minimum Measured Power (dBm)	Specification w/out Option 2 (dBm) ⁽¹⁾	Specification with Option 2 (dBm) ⁽¹⁾	Measurement Uncertainty (dB)
Minimum Frequency ⁽³⁾ to < 2.0 w/Option 5 ≤ 2.2 w/Option 4	SC7400	10		+16.0	+15.0	0.268
≥ 2.0 to 20 w/Option 5 > 2.2 to 20 w/Option 4	SC7430 or SC7570	50		+19.0	+18.0	0.454
> 20 to ≤ 40.0	SC7430 or SC7570	50		+16.0	+14.0	0.584
> 40 to ≤ Maximum Frequency ⁽⁴⁾	SC7430 or SC7570	90		+9.0	+6.0 ⁽²⁾	1.716

1. For models with Option 22, derate specification by 2 dB.
2. Typical 60 to 67 GHz.
3. 100K if Option 22 installed or 10 MHz if Options 4 or 5 installed.
4. 67 (65) GHz for MG3696B without option 2 or 60 GHz for MG3696B with option 2.

Test Records

MG369__B	Firmware Revision:	Operator:
Serial Number:	Date:	Options:

Section 3-10 Frequency Modulation Test

All MG369xB Models with Option 12, 25X, or 28X (1 of 5)

Locked External FM Accuracy at 5 GHz

Measured Test Results	Specification	Measurement Uncertainty
Vmodon =	N/A	None
Vmodoff =	N/A	None
FMerror% =	10%	1.5%

Locked Low-Noise External FM Accuracy at 5 GHz

Measured Test Results	Specification	Measurement Uncertainty
Vmodon =	N/A	None
Vmodoff =	N/A	None
FMerror% =	10%	1.5%

Locked External FM Accuracy at 20 GHz

Measured Test Results	Specification	Measurement Uncertainty
Vmodon =	N/A	None
Vmodoff =	N/A	None
FMerror% =	10%	1.5%

Locked Low-Noise External FM Accuracy at 20 GHz

Measured Test Results	Specification	Measurement Uncertainty
Vmodon =	N/A	None
Vmodoff =	N/A	None
FMerror% =	10%	1.5%

Locked Internal FM Accuracy at 5 GHz

Measured Test Results	Specification	Measurement Uncertainty
Vmodon =	N/A	None
Vmodoff =	N/A	None
FMerror% =	10%	1.5%

MG369__B	Firmware Revision:	Operator:
Serial Number:	Date:	Options:

Section 3-10 Frequency Modulation Test

All MG369xB Models with Option 12, 25X, or 28X (2 of 5)

Locked Low-Noise Internal FM Accuracy at 5 GHz

Measured Test Results	Specification	Measurement Uncertainty
Vmodon =	N/A	None
Vmodoff =	N/A	None
FMerror% =	10%	1.5%

Locked Internal FM Accuracy at 20 GHz

Measured Test Results	Specification	Measurement Uncertainty
Vmodon =	N/A	None
Vmodoff =	N/A	None
FMerror% =	10%	1.5%

Locked Low-Noise Internal FM Accuracy at 20 GHz

Measured Test Results	Specification	Measurement Uncertainty
Vmodon =	N/A	None
Vmodoff =	N/A	None
FMerror% =	10%	1.5%

Wide External Φ M Accuracy at 5 GHz

Measured Test Results	Specification	Measurement Uncertainty
Vmodon =	N/A	None
Vmodoff =	N/A	None
Φ Merror% =	10%	1.5%

Narrow External Φ M Accuracy at 5 GHz

Measured Test Results	Specification	Measurement Uncertainty
Vmodon =	N/A	None
Vmodoff =	N/A	None
Φ Merror% =	10%	1.5%

Test Records

MG369__B	Firmware Revision:	Operator:
Serial Number:	Date:	Options:

Section 3-10 Frequency Modulation Test

All MG369xB Models with Option 12, 25X, or 28X (3 of 5)

Wide External Φ M Accuracy at 20 GHz

Measured Test Results	Specification	Measurement Uncertainty
Vmodon =	N/A	None
Vmodoff =	N/A	None
Φ Merror% =	10%	1.5%

Narrow External Φ M Accuracy at 20 GHz

Measured Test Results	Specification	Measurement Uncertainty
Vmodon =	N/A	None
Vmodoff =	N/A	None
Φ Merror% =	10%	1.5%

Wide Internal Φ M Accuracy at 5 GHz

Measured Test Results	Specification	Measurement Uncertainty
Vmodon =	N/A	None
Vmodoff =	N/A	None
Φ Merror% =	10%	1.5%

Narrow Internal Φ M Accuracy at 5 GHz

Measured Test Results	Specification	Measurement Uncertainty
Vmodon =	N/A	None
Vmodoff =	N/A	None
Φ Merror% =	10%	1.5%

Wide Internal Φ M Accuracy at 20 GHz

Measured Test Results	Specification	Measurement Uncertainty
Vmodon =	N/A	None
Vmodoff =	N/A	None
Φ Merror% =	10%	1.5%

MG369__B	Firmware Revision:	Operator:
Serial Number:	Date:	Options:

Section 3-10 Frequency Modulation Test

All MG369xB Models with Option 12, 25X, or 28X (4 of 5)

Narrow Internal Φ M Accuracy at 20 GHz

Measured Test Results	Specification	Measurement Uncertainty
Vmodon =	N/A	None
Vmodoff =	N/A	None
Φ Merror% =	10%	1.5%

Locked External FM Flatness

Function Generator Frequency	MG369xB FM Sensitivity	Vmodoff (dBm)	Vmodon (dBm)	Mod Index	FMflat (dB)	Specification (dB)	Measurement Uncertainty (dB)
10 kHz	10 kHz/V					± 1.0	0.07
20 kHz	20 kHz/V					± 1.0	0.07
50 kHz	50 kHz/V					± 1.0	0.07
99.8 kHz ⁽¹⁾	99.8 kHz/V				Reference	-	-
200 kHz	200 kHz/V					± 1.0	0.07
500 kHz	500 MHz/V					± 1.0	0.07
1 MHz	1 MHz/V					± 1.0	0.07
9.98 MHz ⁽²⁾	9.98 MHz/V ⁽³⁾					± 3.0	0.07

Narrow External Φ M Flatness

Function Generator Frequency	MG369xB Φ M Sensitivity	Vmodoff (dBm)	Vmodon (dBm)	Mod Index	FMflat (dB)	Specification (dB)	Measurement Uncertainty (dB)
10 kHz	1 rad/V					± 1.0	0.07
20 kHz	1 rad/V					± 1.0	0.07
50 kHz	1 rad/V					± 1.0	0.07
99.8 kHz ⁽¹⁾	1 rad/V				Reference	-	-
200 kHz	1 rad/V					± 1.0	0.07
500 kHz	1 rad/V					± 1.0	0.07
1 MHz	1 rad/V					± 1.0	0.07
10 MHz ⁽²⁾	1 rad/V ⁽³⁾					± 3.0	0.07

1.A potential spurious beat note exists at a 100 kHz rate that can interfere with the carrier frequency null measurement. Therefore, The measurement is performed at a 99.8 kHz rate with a function generator multimeter reading of 0.7070 Vrms.

2.Bandwidth test.

3.VBW set may need to be reduced to 30 Hz to obtain a stable reading.

Test Records

MG369__B	Firmware Revision:	Operator:
Serial Number:	Date:	Options:

Section 3-10 Frequency Modulation Test

All MG369xB Models with Option 12, 25X, or 28X (5 of 5)

Wide External Φ M Flatness

Function Generator Frequency	MG369xB Φ M Sensitivity	Vmodoff (dBm)	Vmodon (dBm)	Mod Index	FMflat (dB)	Specification (dB)	Measurement Uncertainty (dB)
10 kHz	1 rad/V					± 1.0	0.07
20 kHz	1 rad/V					± 1.0	0.07
50 kHz	1 rad/V					± 1.0	0.07
99.8 kHz ⁽¹⁾	1 rad/V				Reference	–	–
200 kHz	1 rad/V					± 1.0	0.07
500 kHz	1 rad/V					± 1.0	0.07

Unlocked Narrow External FM Accuracy at 5 GHz

FMref (GHz)	FMmod (GHz)	FMerr (%)	Specification	Measurement Uncertainty
			10 %	0.1 %

MG369__B	Firmware Revision:	Operator:
Serial Number:	Date:	Options:

Section 3-11 Amplitude Modulation Test

All MG369xB Models with Option 14, 25X, or 28X (1 of 4)

External AM Accuracy vs. Frequency at 50% Modulation

DUT Frequency (GHz)	LO Frequency (GHz)	M (%)	Specification (%)	Measurement Uncertainty (± %)
1.0 ⁽¹⁾	n/a ⁽¹⁾		45 to 55	1.0 ± 1 Digit
1.4	1.52053		45 to 55	1.0 ± 1 Digit
2.2	2.32053		45 to 55	1.0 ± 1 Digit
2.3	2.42053		45 to 55	1.0 ± 1 Digit
5.0	5.12053		45 to 55	1.0 ± 1 Digit
8.3	8.42053		45 to 55	1.0 ± 1 Digit
8.4	8.52053		45 to 55	1.0 ± 1 Digit
14.0	14.12053		45 to 55	1.0 ± 1 Digit
20.0	20.12053		45 to 55	1.0 ± 1 Digit
23.0	23.12053		45 to 55	1.0 ± 1 Digit
26.5	26.37947		45 to 55	1.0 ± 1 Digit
30.0	29.87947		45 to 55	1.0 ± 1 Digit
33.0	32.87947		45 to 55	1.0 ± 1 Digit
36.0	35.87947		45 to 55	1.0 ± 1 Digit
40.0	39.87947		45 to 55	1.0 ± 1 Digit

1. Measured directly by modulation analyzer.

Test Records

MG369__B	Firmware Revision:	Operator:
Serial Number:	Date:	Options:

Section 3-11 Amplitude Modulation Test

All MG369xB Models with Option 14, 25X, or 28X (2 of 4)

Internal AM Accuracy vs. Frequency at 50% Modulation

DUT Frequency (GHz)	LO Frequency (GHz)	M (%)	Specification (%)	Measurement Uncertainty (\pm %)
1.0 ⁽¹⁾	n/a ⁽¹⁾		45 to 55	1.0 \pm 1 Digit
1.4	1.52053		45 to 55	1.0 \pm 1 Digit
2.2	2.32053		45 to 55	1.0 \pm 1 Digit
2.3	2.42053		45 to 55	1.0 \pm 1 Digit
5.0	5.12053		45 to 55	1.0 \pm 1 Digit
8.3	8.42053		45 to 55	1.0 \pm 1 Digit
8.4	8.52053		45 to 55	1.0 \pm 1 Digit
14.0	14.12053		45 to 55	1.0 \pm 1 Digit
20.0	20.12053		45 to 55	1.0 \pm 1 Digit
23.0	23.12053		45 to 55	1.0 \pm 1 Digit
26.5	26.37947		45 to 55	1.0 \pm 1 Digit
30.0	29.87947		45 to 55	1.0 \pm 1 Digit
33.0	32.87947		45 to 55	1.0 \pm 1 Digit
36.0	35.87947		45 to 55	1.0 \pm 1 Digit
40.0	39.87947		45 to 55	1.0 \pm 1 Digit

1. Measured directly by modulation analyzer.

MG369__B	Firmware Revision:	Operator:
Serial Number:	Date:	Options:

Section 3-11 Amplitude Modulation Test

All MG369xB Models with Option 14, 25X, or 28X (3 of 4)

AM Roll Off at 50 kHz Bandwidth

DUT Frequency (GHz)	LO Frequency (GHz)	V ₁ Multimeter Reading (Volts)	V ₅₀ Multimeter Reading (Volts)	Calculated AM _{r0} (dB)	Specification (dB)	Measurement Uncertainty (dB)
1.0 ⁽¹⁾	n/a ⁽¹⁾				±3.00	±0.02
1.4	1.52053				±3.00	±0.02
2.2	2.32053				±3.00	±0.02
2.3	2.42053				±3.00	±0.02
5.0	5.12053				±3.00	±0.02
8.3	8.42053				±3.00	±0.02
8.4	8.52053				±3.00	±0.02
14.0	14.12053				±3.00	±0.02
20.0	20.12053				±3.00	±0.02
23.0	23.12053				±3.00	±0.02
26.5	26.37947				±3.00	±0.02
30.0	29.87947				±3.00	±0.02
33.0	32.87947				±3.00	±0.02
36.0	35.87947				±3.00	±0.02
40.0	39.87947				±3.00	±0.02

1. Measured directly by modulation analyzer.

Test Records

MG369__B	Firmware Revision:	Operator:
Serial Number:	Date:	Options:

Section 3-11 Amplitude Modulation Test

All MG369xB Models with Option 14, 25X, or 28X (4 of 4)

AM Flatness

DUT F1 (GHz)	LO F1 (GHz)	V ₀ (V)	V ₁ (V)	V ₂ (V)	V ₃ (V)	V ₄ (V)	V ₅ (V)	V ₆ (V)	V ₇ (V)	V ₈ (V)	V ₉ (V)	V ₁₀ (V)	AM _{flat} (dB)	Spec. (dB)	MU (dB)
1.0 ⁽¹⁾	n/a ⁽¹⁾													±0.30	±0.02
1.4	1.52053													±0.30	±0.02
2.2	2.32053													±0.30	±0.02
2.3	2.42053													±0.30	±0.02
5.0	5.12053													±0.30	±0.02
8.3	8.42053													±0.30	±0.02
8.4	8.52053													±0.30	±0.02
14.0	14.12053													±0.30	±0.02
20.0	20.12053													±0.30	±0.02
23.0	23.12053													±0.30	±0.02
26.5	26.37947													±0.30	±0.02
30.0	29.87947													±0.30	±0.02
33.0	32.87947													±0.30	±0.02
36.0	35.87947													±0.30	±0.02
40.0	39.87947													±0.30	±0.02

1. Measured directly by modulation analyzer.

MG369__B	Firmware Revision:	Operator:
Serial Number:	Date:	Options:

Section 3-12 Pulse Modulation Test

All MG369XB Models with Option 13, 24, 26X, or 27 (1 of 3)

Pulse Rise and Fall Times

DUT Frequency (GHz)	Rise Time (ns)	Fall Time (ns)	Specification (ns)	Measurement Uncertainty (\pm ns)
0.500 000 001			N/A (Option 4) 10 (Option 5)	0.023
1.200 000 001			N/A (Option 4) 10 (Option 5)	0.023
1.900 000 001			N/A (Option 4) 10 (Option 5)	0.023
5.000 000 001			10	0.023
14.000 000 001			10	0.023
22.000 000 001			10	0.023
28.000 000 001			10	0.023
34.000 000 001			10	0.023
41.000 000 001			10	0.023

Pulse Overshoot

DUT Frequency (GHz)	Overshoot (%)	Specification (%)	Measurement Uncertainty (%)
0.500 000 001		10 (Option 4) 10 (Option 5)	5
1.200 000 001		10 (Option 4) 10 (Option 5)	5
1.900 000 001		10 (Option 4) 10 (Option 5)	5
5.000 000 001		10	5
14.000 000 001		10	5
22.000 000 001		10	5
28.000 000 001		10	5
34.000 000 001		10	5
41.000 000 001		10 ⁽¹⁾	5

1. For MG3695B and MG3696B overshoot > 40 GHz is 20% typical at rated power and is not tested.

Test Records

MG369__B	Firmware Revision:	Operator:
Serial Number:	Date:	Options:

Section 3-12 Pulse Modulation Test

All MG369XB Models with Option 13, 24, 26X, or 27 (2 of 3)

Pulse Power Accuracy (Pulse Width $\geq 1 \mu\text{s}$)

DUT Frequency (GHz)	V _{ref} (Volts)	V _{pulse} (Volts)	P _{accuracy} (dB)	Specification (dB)	Measurement Uncertainty (dB)
0.050 000 001				± 0.5	0.1
1.200 000 001				± 0.5	0.1
1.900 000 001				± 0.5	0.1
5.000 000 001				± 0.5	0.1
14.000 000 001				± 0.5	0.1
22.000 000 001				± 0.5	0.1
28.000 000 001				± 0.5	0.1
34.000 000 001				± 0.5	0.1
41.000 000 001				± 0.5	0.1

Pulse Power Accuracy (Pulse Width $< 1 \mu\text{s}$)

DUT Frequency (GHz)	V _{ref} (Volts)	V _{pulse} (Volts)	P _{accuracy} (dB)	Specification (dB)	Measurement Uncertainty (dB)
2.200 000 001				± 1.0	0.1
5.000 000 001				± 1.0	0.1
14.000 000 001				± 1.0	0.1
22.000 000 001				± 1.0	0.1
28.000 000 001				± 1.0	0.1
34.000 000 001				± 1.0	0.1
41.000 000 001				± 1.0	0.1

MG369__B	Firmware Revision:	Operator:
Serial Number:	Date:	Options:

Section 3-12 Pulse Modulation Test

All MG369XB Models with Option 13, 24, 26X, or 27 (3 of 3)

Pulse On/Off Ratio

DUT Frequency (GHz)	P _{depth} (dB)	Specification (dB) ⁽¹⁾	Measurement Uncertainty (dB)
0.010		-80	0.9
1.0		-80	0.9
1.4		-80	0.9
2.0		-80	0.9
2.2		-80	1.0
2.3		-80	1.0
5.0		-80	1.7
8.3		-80	2.6
8.4		-80	2.6
14.0		-80	2.5
20.0		-80	2.5
23.0		-80	3.3
26.5		-80	3.3
30.0		-80	3.1
33.0		-80	3.2
36.0		-80	3.2
40.0		-80	3.2
50.0		-80	3.2

1. For models with Option 15x, specification is 70 dB.

Test Records

MG369__B	Firmware Revision:	Operator:
Serial Number:	Date:	Options:

Section 4-7 Preliminary Calibration

Procedure Step	Step Completion
1. Internal DVM Calibration (calterm119)	
2. Coarse Loop Pre-tune DAC Calibration (calterm 137)	
3. Sweep Time DAC Calibration (calterm 132)	
4. If Option 6 is Installed then YIG Offset Calibration (calterm 134)	
5. YIG Frequency Linearizer DACs Calibration (calterm 127)	
6. 10 MHz Reference Oscillator Calibration (calterm 130)	
7. Ramp Center DAC Calibration (calterm 129)	
8. Sweep Width DAC Calibration (calterm 133)	
9. Center Frequency DAC Calibration (calterm 114)	
10. Store the Calibration Data (calterm 787)	

MG369__B	Firmware Revision:	Operator:
Serial Number:	Date:	Options:

Section 4-8 Frequency Synthesis Test (1 of 3)

MG3691B	
Coarse Loop ⁽¹⁾	
2.000 000 000 00	
5.000 000 000 00	
8.000 000 000 00	
10.000 000 000 00	
Fine Loop ⁽²⁾	
2.000 000 100 00	
2.000 000 200 00	
2.000 000 300 00	
2.000 000 400 00	
2.000 000 500 00	
2.000 000 600 00	
2.000 000 700 00	
2.000 000 800 00	
2.000 000 900 00	
2.000 001 000 00	

MG3692B	
Coarse Loop ⁽¹⁾	
2.000 000 000 00	
5.000 000 000 00	
8.000 000 000 00	
11.000 000 000 00	
14.000 000 000 00	
17.000 000 000 00	
20.000 000 000 00	
Fine Loop ⁽²⁾	
2.000 000 100 00	
2.000 000 200 00	
2.000 000 300 00	
2.000 000 400 00	
2.000 000 500 00	
2.000 000 600 00	
2.000 000 700 00	
2.000 000 800 00	
2.000 000 900 00	
2.000 001 000 00	

Test Records

MG369__B	Firmware Revision:	Operator:
Serial Number:	Date:	Options:

Section 4-8 Frequency Synthesis Test (2 of 3)

MG3693B	
Coarse Loop ⁽¹⁾	
2.000 000 000 00	
5.000 000 000 00	
8.000 000 000 00	
11.000 000 000 00	
14.000 000 000 00	
17.000 000 000 00	
20.000 000 000 00	
23.000 000 000 00	
26.000 000 000 00	
29.000 000 000 00	
30.000 000 000 00	
Fine Loop ⁽²⁾	
2.000 000 100 00	
2.000 000 200 00	
2.000 000 300 00	
2.000 000 400 00	
2.000 000 500 00	
2.000 000 600 00	
2.000 000 700 00	
2.000 000 800 00	
2.000 000 900 00	
2.000 001 000 00	

MG3694B	
Coarse Loop ⁽¹⁾	
2.000 000 000 00	
5.000 000 000 00	
8.000 000 000 00	
11.000 000 000 00	
14.000 000 000 00	
17.000 000 000 00	
20.000 000 000 00	
23.000 000 000 00	
26.000 000 000 00	
29.000 000 000 00	
32.000 000 000 00	
35.000 000 000 00	
38.000 000 000 00	
40.000 000 000 00	
Fine Loop ⁽²⁾	
2.000 000 100 00	
2.000 000 200 00	
2.000 000 300 00	
2.000 000 400 00	
2.000 000 500 00	
2.000 000 600 00	
2.000 000 700 00	
2.000 000 800 00	
2.000 000 900 00	
2.000 001 000 00	

1. Tolerance for all frequencies listed above is ±10 Hz. All frequencies are in GHz.

2. Tolerance for all frequencies listed above is ±100 Hz. All frequencies are in GHz.

MG369__B	Firmware Revision:	Operator:
Serial Number:	Date:	Options:

Section 4-8 Frequency Synthesis Test (3 of 3)

MG3695B	
Coarse Loop ⁽¹⁾	
2.000 000 000 00	
5.000 000 000 00	
8.000 000 000 00	
11.000 000 000 00	
14.000 000 000 00	
17.000 000 000 00	
20.000 000 000 00	
23.000 000 000 00	
26.000 000 000 00	
29.000 000 000 00	
32.000 000 000 00	
35.000 000 000 00	
38.000 000 000 00	
40.000 000 000 00	
50.000 000 000 00 ⁽²⁾	
Fine Loop ⁽³⁾	
2.000 000 100 00	
2.000 000 200 00	
2.000 000 300 00	
2.000 000 400 00	
2.000 000 500 00	
2.000 000 600 00	
2.000 000 700 00	
2.000 000 800 00	
2.000 000 900 00	
2.000 001 000 00	

MG3696B	
Coarse Loop ⁽¹⁾	
2.000 000 000 00*	
5.000 000 000 00	
8.000 000 000 00	
11.000 000 000 00	
14.000 000 000 00	
17.000 000 000 00	
20.000 000 000 00	
23.000 000 000 00	
26.000 000 000 00	
29.000 000 000 00	
32.000 000 000 00	
35.000 000 000 00	
38.000 000 000 00	
40.000 000 000 00	
65.000 000 000 00 ⁽²⁾	
Fine Loop ⁽³⁾	
2.000 000 100 00	
2.000 000 200 00	
2.000 000 300 00	
2.000 000 400 00	
2.000 000 500 00	
2.000 000 600 00	
2.000 000 700 00	
2.000 000 800 00	
2.000 000 900 00	
2.000 001 000 00	

- 1.Tolerance for all frequencies listed above is ±10 Hz. All frequencies are in GHz.
- 2.Tolerance for all frequencies listed above is ±100 Hz. All frequencies are in GHz.
- 3.Only if test equipment capable of taking the measurement is available.

Test Records

MG369__B	Firmware Revision:	Operator:
Serial Number:	Date:	Options:

Section 4-9 Switched Filter Shaper Calibration

Procedure Step	Step Completion
Log Amplifier Zero Calibration 1. Log Amplifier Zero Calibration (calterm 115)	
Limiter DAC Adjustment (MG369_B with Option 15) 2. Limiter DAC Adjustment (calterm 145)	
Shaper DAC Adjustment 3. Shaper DAC Adjustment (calterm 138) 4. Store the Calibration Data (calterm 787)	

Section 4-10 RF Level Calibration

This calibration is performed using an automatic test system. Contact Anritsu Customer Service for further information.

Section 4-11 ALC Bandwidth Calibration

Procedure Step	Step Completion
1. ALC Bandwidth Calibration (Calterm 110)	
2. Store the Calibration Data (calterm 787)	

Section 4-12 ALC Slope Calibration

Procedure Step	Step Completion
1. ALC Slope Calibration (slpcal)	
2. Store the Calibration Data (calterm 787)	

MG369__B	Firmware Revision:	Operator:
Serial Number:	Date:	Options:

Section 4-13 AM Calibration

Procedure Step	Step Completion
1. Linear AM Calibration (calterm 112)	
2. Linear AM Calibration SDM (calterm 172)	
3. Log AM Calibration (calterm 113)	
4. Log AM Calibration SDM (calterm 173)	
5. AM Function Generator Calibration (calterm 146)	
6. AM Meter Calibration (calterm 147)	
7. Store the Calibration Data (calterm 787)	

Section 4-14 FM Calibration

Procedure Step	Step Completion
1. FM Variable Gain Linearity Calibration (calterm 148)	
2. FM Narrow Mode Sensitivity Calibration (calterm 125)	
3. Φ M External Wide Sensitivity Calibration (calterm 149)	
4. Φ M External Narrow Sensitivity Calibration (calterm 150)	
5. Φ M Wide Flatness Calibration (calterm 155)	
6. Φ M Narrow Flatness Calibration (calterm 156)	
7. FM Meter calibration (calterm 123)	
8. FM Function Generator Calibration (calterm 154)	
9. Store the Calibration Data (calterm 787)	

Test Records

MG369__B	Firmware Revision:	Operator:
Serial Number:	Date:	Options:

Appendix B — Technical Data Sheet

B-1 MG369xB Technical Data Sheet

The latest version of the MG369xB RF/Microwave Signal Generators Technical Data Sheet, Anritsu PN: 11410-00344, can be downloaded from the Anritsu Internet site:

<http://www.anritsu.com>

The data sheet provides performance specifications for all of the various models in the MG369xB series.

Index

- A**
- A2 Microprocessor PCB 6-10
 - A3 Reference PCB 6-11
 - A4 Coarse Loop PCB 6-12
 - A5 to A9 PCB 6-14
 - A9 YIG Assembly 2-2
 - ALC 2-12
 - ALC and Modulation Subsystem
 - Block Diagram 2-7, 2-8
 - Troubleshooting 5-19
 - ALC Loop Operation 2-12
 - ALC Slope 2-13
 - ALC/AM/Pulse Modulator 2-2
 - AM Calibration 4-26
 - AM Flatness 3-53
 - AM Roll Off 3-51
 - Amplitude Modulation 2-13
 - Amplitude Modulation Tests 3-48
 - Analog Sweep Mode 2-11
 - Anritsu, contact 1-2
 - Attenuator 2-16
 - Auxiliary
 - Troubleshooting 5-18
- C**
- Calibration
 - ALC Slope Calibration 4-21
 - Alternate Reference Calibration 4-11
 - AM Calibration 4-25
 - Bandwidth 4-21
 - FM Calibration 4-28
 - Limiter 4-15
 - Log Amplifier 4-14
 - Preliminary Calibration 4-9
 - RF Level Calibration 4-16
 - Shaper 4-16
 - Subassembly Replacement 4-5
 - Switched Filter Shaper 4-14
 - Test Equipment 4-1
 - calibration
 - Initial Setup 4-6
 - Chassis Cover 6-7
 - Coarse Loop
 - Testing 4-12
 - Troubleshooting 5-16
 - contacting Anritsu 1-2
- D**
- Diagnostics
 - Internal Self-Test 5-1
 - Digital Control 2-1
 - Digital Down Converter 2-15
 - Doubler Module 2-15
- E**
- Down Converter 2-15
 - Functional Description 2-15
 - Troubleshooting 5-17
 - DVM
 - Troubleshooting 5-13
- E**
- Error Messages 5-1, 5-3
 - Self-Test 5-1
 - ESD Requirements 1-3, 5-1
 - External Leveling 2-12
- F**
- Fine Loop
 - PCB 6-11
 - Testing 4-13
 - Troubleshooting 5-14
 - Flatness Test 3-22
 - FM PCB Troubleshooting 5-18
 - Frequency Modulation 2-11
 - Tests 3-32
 - Frequency Synthesis 2-2, 2-6
 - Front Panel Assembly 2-1, 6-9
- H**
- harmonic test 3-8
- I**
- Identification Number 1-1
 - Inputs/Outputs 2-3
 - Internal AM Accuracy 3-50
- L**
- Level Accuracy 3-22
 - Level Flatness 3-28
 - Links
 - contacting Anritsu 1-2
- M**
- Maintenance 1-3, 1-4
 - Measurement Uncertainty 3-5
 - Modulation Index Calculations 3-44
 - Motherboard/Interconnections 2-3
- O**
- Online Manual 1-1
- P**
- PC Setup 4-7
 - Phase Modulation 2-11
 - Tests 3-32
 - Phase Noise 3-12
 - Power Level Accuracy 3-22
 - Power Supply 2-2, 6-17
 - Power Sweep 2-13
 - Preventive Maintenance 1-4

Pulse Generator 2-13
 Pulse Modulation Operation 2-13
 Pulse On/Off Ratio 3-59
 Pulse Power Accuracy 3-58

Q

Quadrupler Module 2-16

R

Related Manuals 1-2
 Replaceable Parts 6-1
 Replacement Parts 4-5
 RF Deck 2-2, 2-14
 RF Outputs 2-10
 RF Signal Filtering 2-14

S

Safety Symbols 1-1
 Spurious Signals 3-8
 SQM Operation 2-16
 Startup Configuration 1-5
 Step Sweep Mode 2-12

T

Test Equipment 1-6
 Test Records
 ALC Bandwidth Calibration A-80
 ALC Slope Calibration A-80
 AM Calibration A-81
 Amplitude Modulation A-69
 FM Calibration A-81
 Frequency Modulation Test A-64
 Frequency Synthesis A-77
 Harmonics and Harmonically Related Signal A-3,

..... A-5
 Internal Time Base Aging Rate A-2
 Maximum Leveled Power Test A-57
 Non-Harmonics Signal A-7, A-10, A-12
 Power Level Accuracy Test A-39
 Power Level Flatness A-53
 Power Level Log Conformity A-37
 Preliminary Calibration A-76
 Pulse Modulation A-73
 RF Level Calibration A-80
 Single Sideband Phase Noise A-13, A-25
 Switched Filter Shaper Calibration A-80
 Troubleshooting 5-1, 5-6
 ALC 5-19
 Auxiliary PCB 5-18

U

URL contacting Anritsu 1-2

W

Warning/Status Messages 5-3
 Website, Contacting Anritsu 1-2

Y

YIG Loop Testing 4-12
 YIG-tuned Oscillator 2-14

Anritsu



Anritsu utilizes recycled paper and environmentally conscious inks and toner.

Anritsu Company
490 Jarvis Drive
Morgan Hill, CA 95037-2809
USA
<http://www.anritsu.com>